

4 Port Solenoid Valve Cassette Type Manifold

Rubber Seal

New
CE c **UL**® US

New Plug-in
cable type
manifold is added !

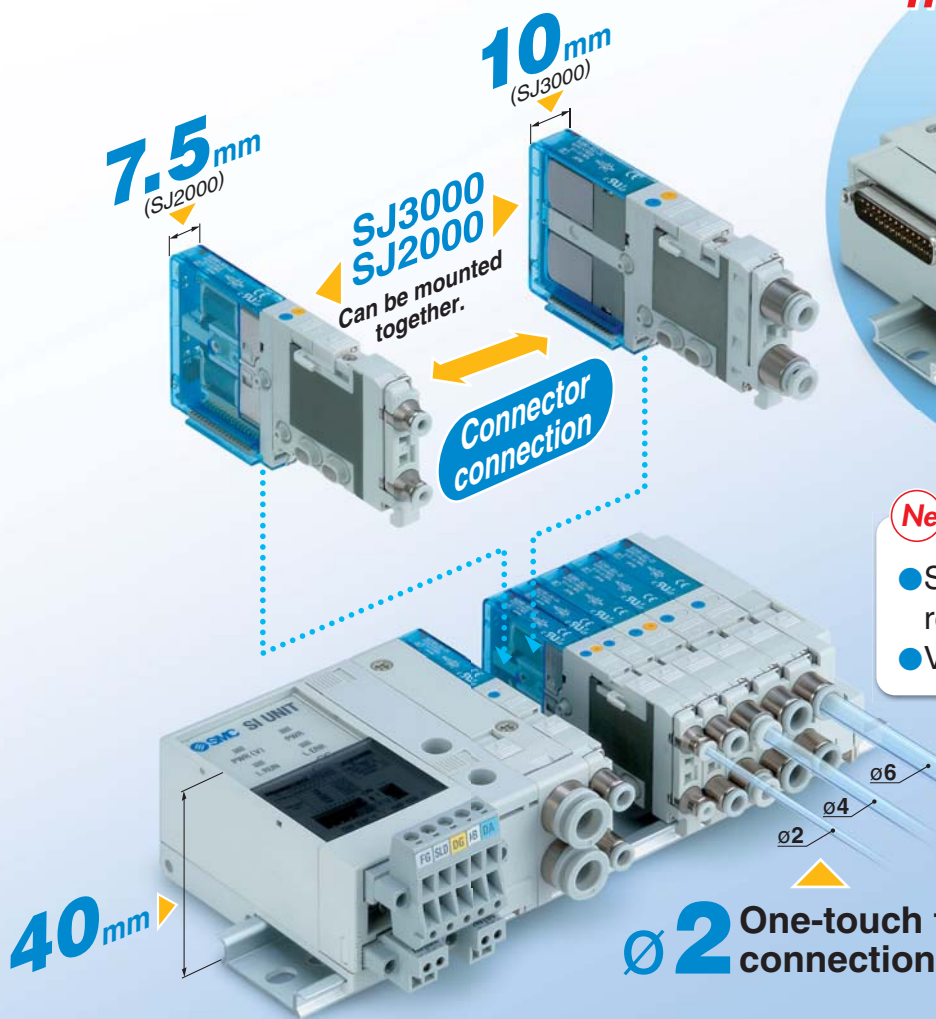

New Additional options are now available.

- SUP/EXH block assembly with regulator and pressure switch
- Valve with speed controller

New An additional type of manual override is now available.

- Slide locking type

Ø 2 One-touch fitting connection is possible.

● Non plug-in type
Individual wiring manifold



● Vacuum release valve with restrictor
Suction and release can be controlled with a single unit.

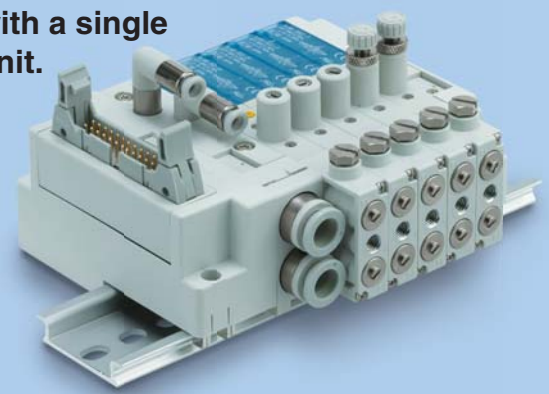

Series **SJ2000/3000**

4 Port Solenoid Valve Cassette Type Manifold

Power consumption

0.15 W (SJ3000 with power saving circuit)
0.23 W (SJ2000 with power saving circuit)

Service life of 50 million cycles or more

(Based on SMC life test conditions)

Connector type (Card edge type)

Series SJ2000 and SJ3000 can be mounted together.

- Can easily increase or decrease stations and replace valves.
- 34 pins connector allows up to 16 stations with double solenoids, 32 stations with single solenoids.

Non plug-in individual wiring compliant, too

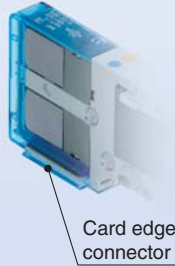

Manifold uses halogen-free lead wires.

New Plug-in cable type manifold

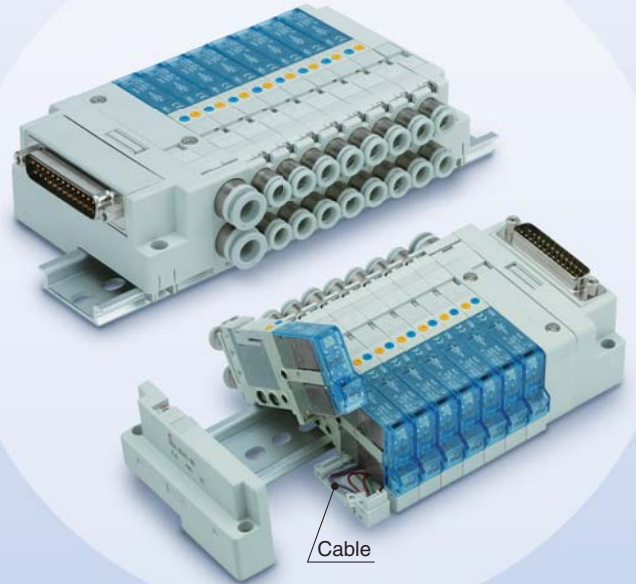

Piping variations

With One-touch fittings

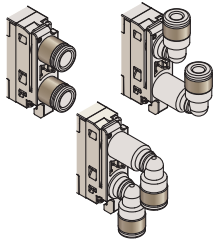

Threaded type

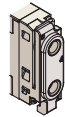

Threaded type is not available for 1(P), 3/5(E) port.

With switch (Connector type)

- Possible to shut the signal of each valves individually.
- Manual operation is possible by switching OFF, even when the valve is in the energised state.

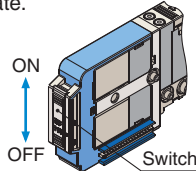

The valve coil is kept in a deenergised state even when there is an electric signal from the manifold side connector, and this enables manifold operation.

Manual locking

Prevents wrong operation by sliding the switch to avoid a manual button from being pressed.



Fittings are replaceable.

Fittings (including type and size) can be easily changed by removing a clip.

Details ▶ P.99

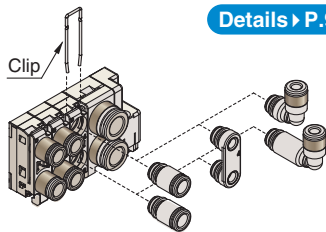

Valve connection mechanism

Connection between valves can be fixed by the valve lock switch. Connection can be confirmed with the connection hook inserted into the connection groove of the adjacent valve.

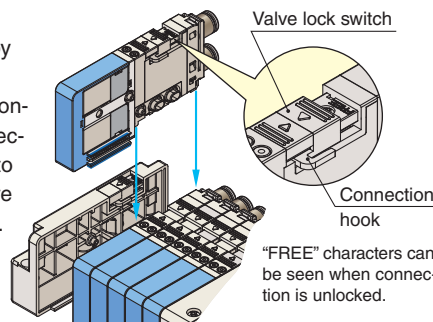

Connector mounting direction

Connector mounting direction can be changed by sliding the switch.

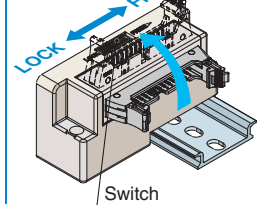

Light indication

SOL.A: ON **Orange**
SOL.B: ON **Green**

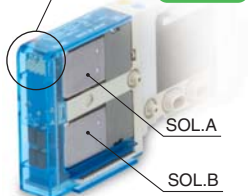

Type of manual override

Non-locking push type

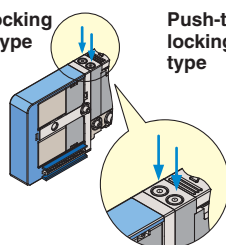

Push-turn locking slotted type

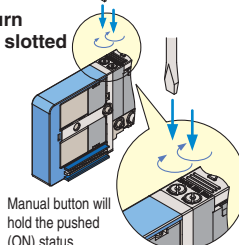

New Slide locking type

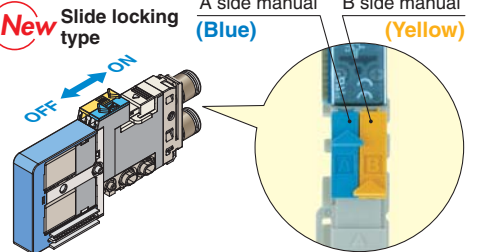

Series SJ2000/3000



PC wiring compliant

* Connector type only.

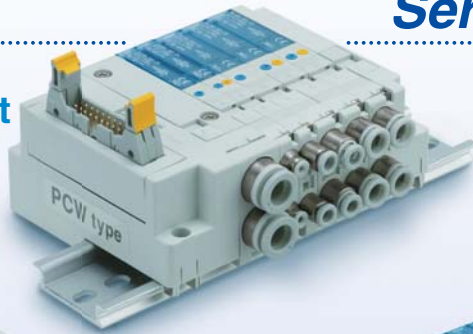

D-sub connector



EX180 Integrated type (for output) serial transmission system

* Connector type only.

Flat ribbon cable



EX510 Gateway system serial transmission system

* Connector type only.

EX180 Integrated type (for output) serial transmission system*

* Connector type only.

■ CC-Link (32 outputs), DeviceNet (32, 16 outputs)

■ Easy attaching/detaching of the SI unit and wiring by the connector

- Separated valve power unit and transmission power unit/Ensuring safety at maintenance
- Selectable between T-branch and straight type of communication connector

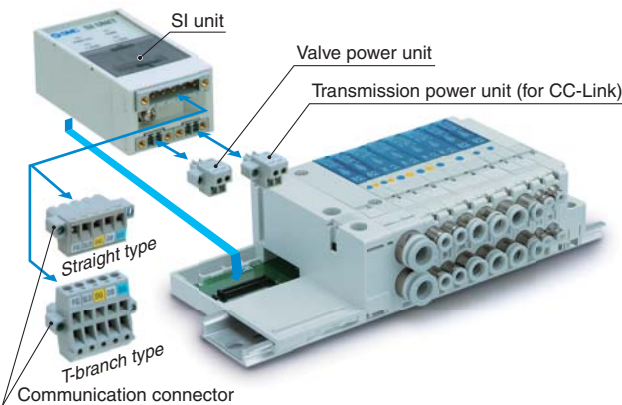

In case of DeviceNet, transmission power unit exists in the communication connector side of T-branch or straight type.

EX510 Gateway system serial transmission system*

* Connector type only.

■ Max. 128 points (Input 64 points/ Output 64 points)

■ All wires can be plugged into the connector units.

■ CC-Link, DeviceNet, PROFIBUS-DP compliant

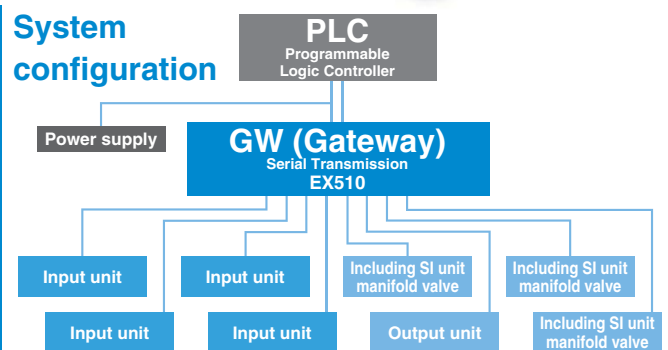

4 position dual 3 port valve

- Integrated to a single valve from 3-port valve
- Possible to control 4(A), 2(B) port individually.
- Can be mounted on the same manifold with a 4-port valve.
- Prepared 3 types of combination
- Label with the same colors of the manual override is attached to show the functions of A side and B side.

A side	B side	Symbol
N.C. valve	N.C. valve	<p>4(A) 2(B) 5(EA) 1(P) 3(EB)</p>
N.O. valve	N.O. valve	<p>4(A) 2(B) 5(EA) 1(P) 3(EB)</p>
N.C. valve	N.O. valve	<p>4(A) 2(B) 5(EA) 1(P) 3(EB)</p>

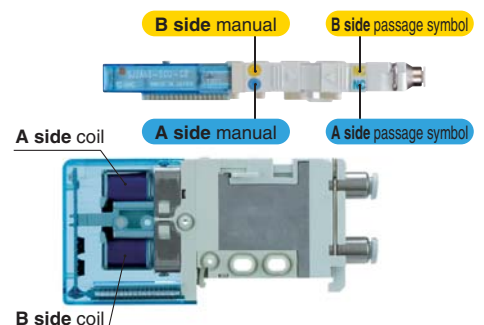

4 Port Solenoid Valve Cassette Type Manifold

Regulator block [Details ▶ P.73](#)

This is a regulator block with the same width (10 mm) as the SJ3000. Pressure supplied from the D side is used to reduce pressure in the manifold. The U side valves are all depressurised from the regulator block.

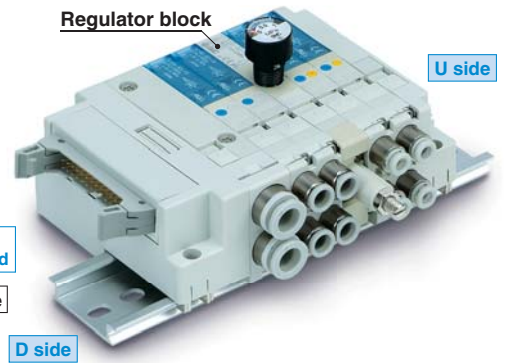

● Pneumatic circuit (example of regulator block installation)

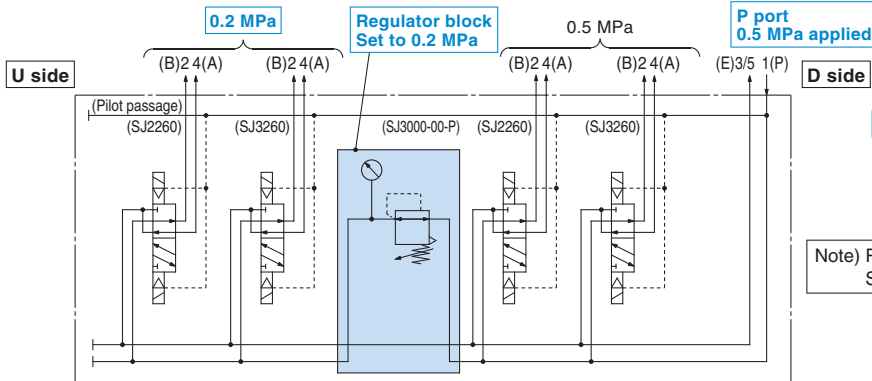

Note) Reduces supply pressure from the D side of the manifold. Supply pressure from the U side cannot be reduced.

● Both the pressure gauge mounting position and the method of operating the pressure adjustment screw can be selected.

SJ3000-00-P(-H)

SJ3000-01-P(-H)

SJ3000-M1-P(-H)

With manual operation of the pressure adjustment screw

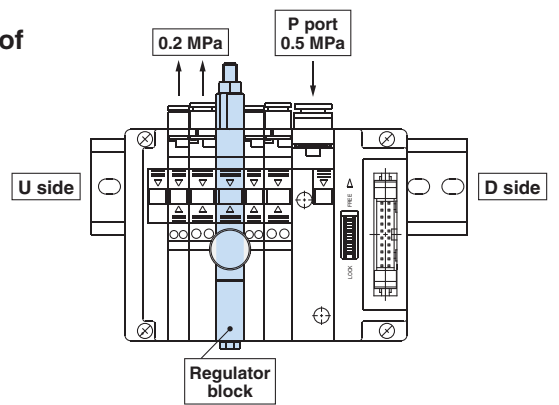
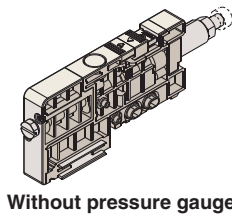
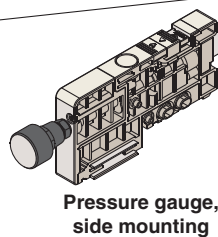
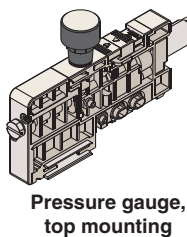

Intermediate connector block assembly [Details ▶ P.79](#)

This connector block can be used by inserting it into the middle of the manifold. This can be used, for example, when you wish to separate electrical control of valves in the same manifold, or when the number of control points is insufficient. The assembly is also compatible with PC wiring with the power supply terminal.

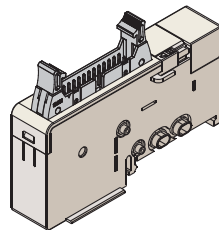

Intermediate connector block assembly

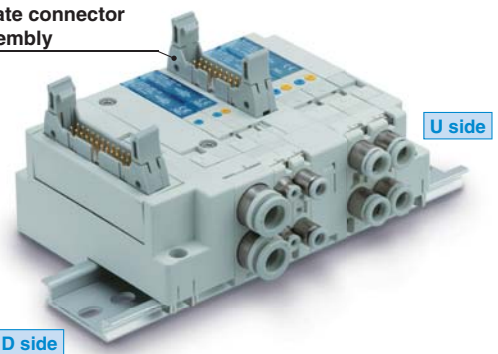

● Intermediate connector block assembly wiring example

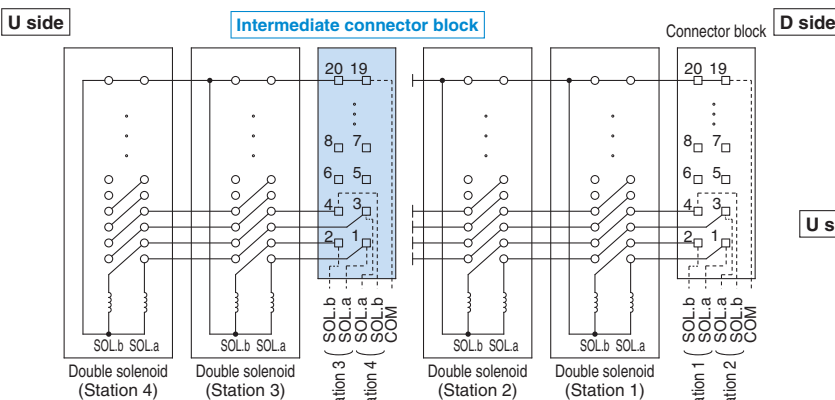

* The U side solenoid valves can be controlled from the position where the intermediate connector block assembly is mounted.

New SUP/EXH block assembly with regulator and pressure switch Details ▶ P.75

This pressure regulator is intended to adjust the SUP pressure of the manifold. Additionally, pressure switch and pressure gauge can be mounted.

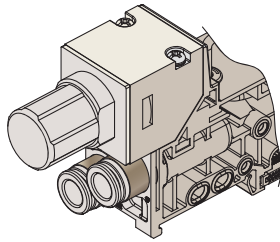

Lateral handle

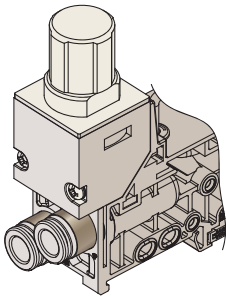

Upward handle

SUP/EXH block assembly with regulator and pressure switch

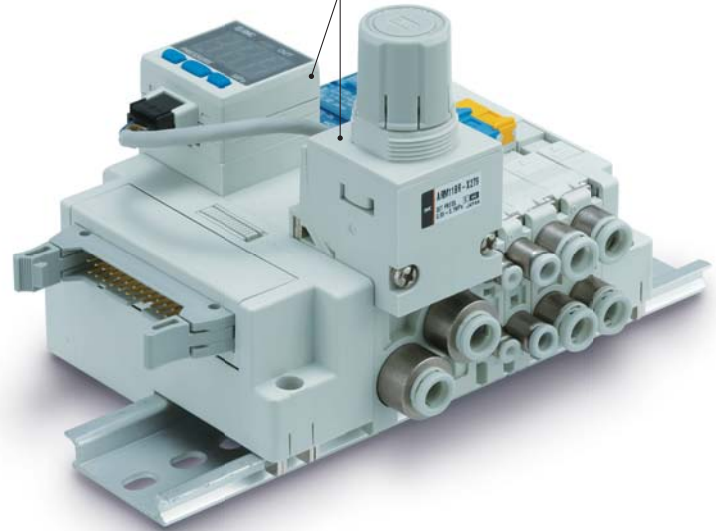

New Valve with speed controller Details ▶ P.75

As a speed controller is built-into this valve, the cylinder speed can be adjusted on the valve side. Two types, meter-in and meter-out, are set.

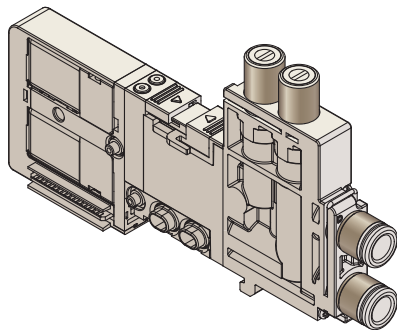

Valve with speed controller
Meter-in: Black
Meter-out: Silver

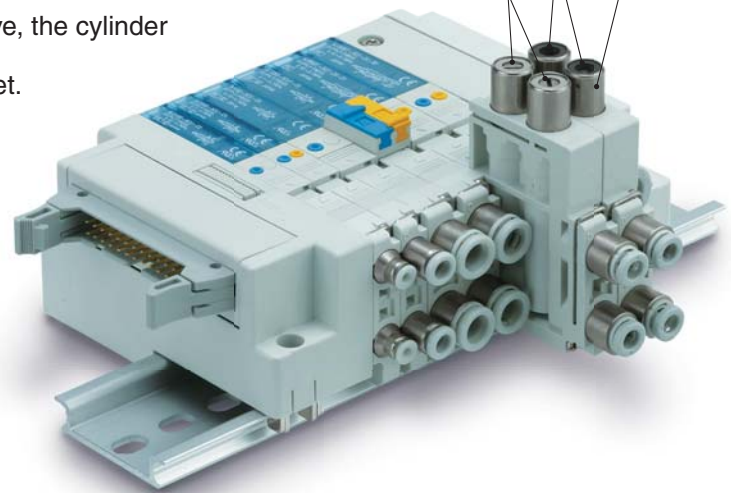

Pneumatic circuit (Installation example of SUP/EXH block assembly with regulator and pressure switch, valve with speed controller)

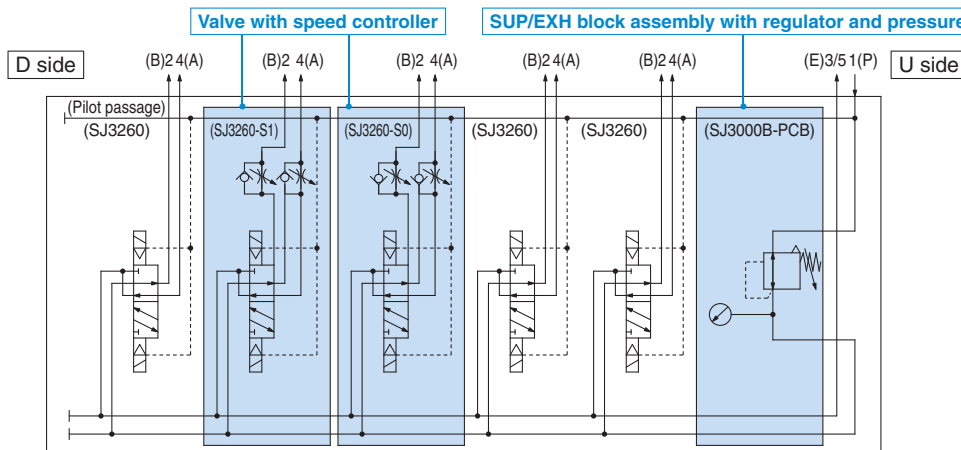

Vacuum Release Valve with Restrictor



Two spool valves are built-in.
Vacuum suction and release can be controlled with a single valve.

Plug-in

Connector connection
New Cable connection

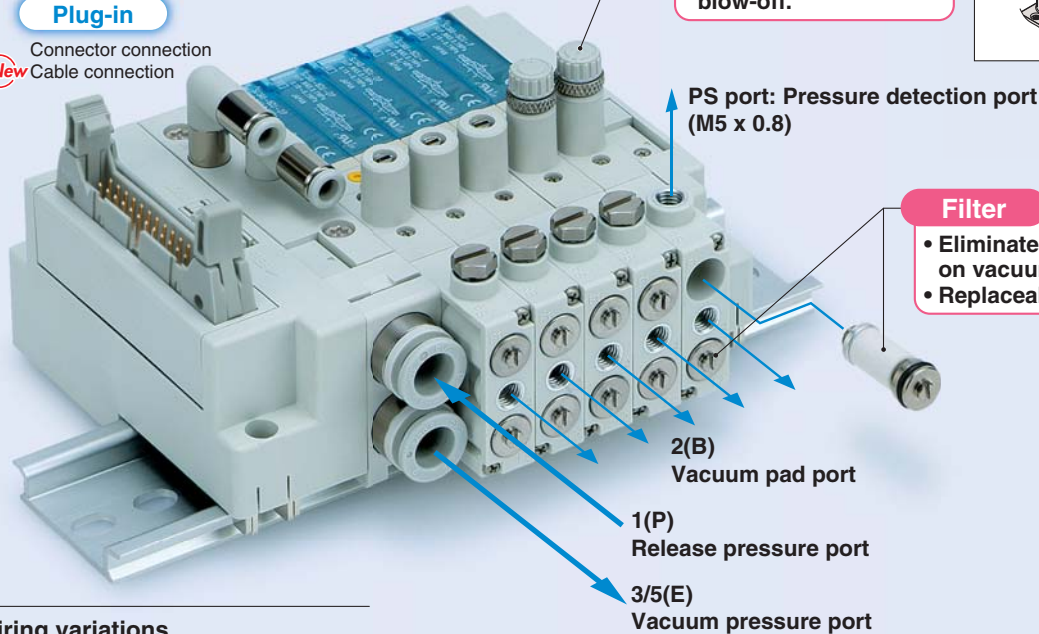

Manual

Slotted locking type

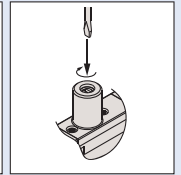
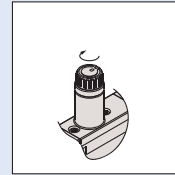

Restrictor

- Flow rate adjustment of release air
- Prevents workpiece blow-off.

Filter

- Eliminates foreign matter on vacuum and release side.
- Replaceable

Wiring variations

<Connector connection>

- D-sub connector
- Flat ribbon cable
- PC wiring
- Serial (EX180)
- Serial (EX510)

<Cable connection>

- D-sub connector
- Flat ribbon cable

Non plug-in

- Individual wiring

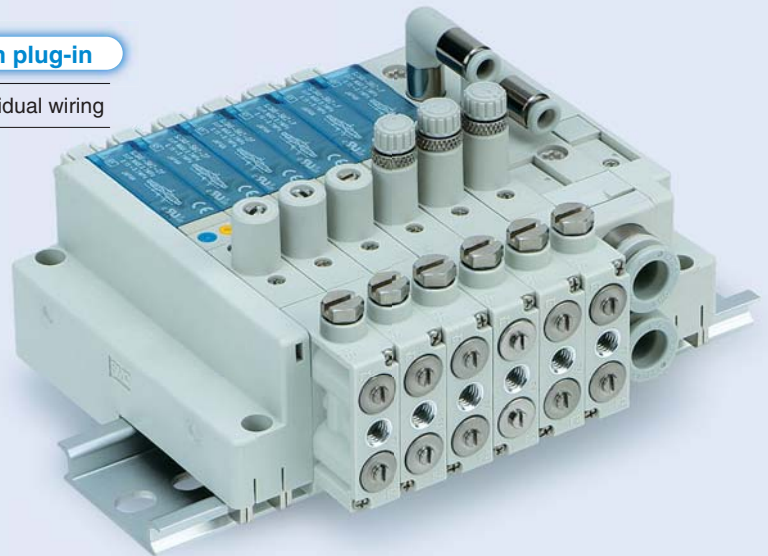

Series SJ3A6

- Power consumption **0.15 W** (with power saving circuit)
- **Width: 10 mm** (same size as Series SJ3000)
- Equipped with restrictor to enable flow rate adjustment of release air.
- Replaceable filters are built-in on the vacuum and release sides.
- Equipped with a pressure detection port enabling connection of a pressure switch, etc.
- Can be **combined** with 4 port solenoid valve, Series SJ2000/3000 (Made to Order).
(Consult SMC for details.)
- Enables **2-system pressure** switching where the 1(P) port and 3/5(E) are set to different positive pressures.
(In this case, flow can be adjusted on the P-port side only.)

Adsorbing and Transferring System Circuit Example

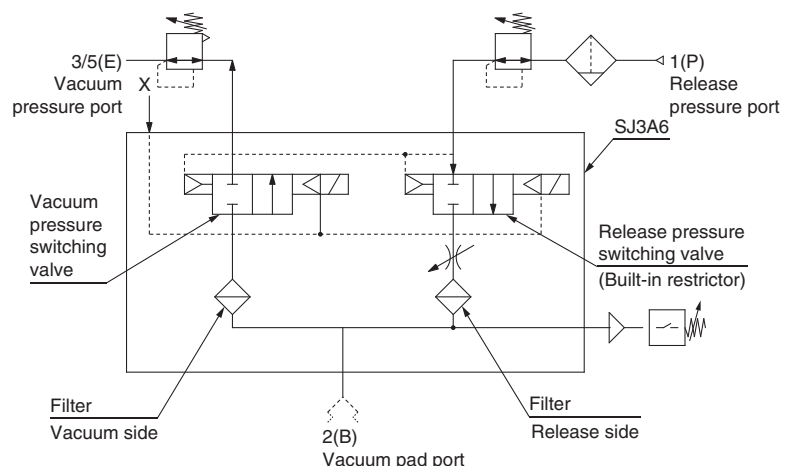

4 Port Solenoid Valve Series SJ2000/3000

Plug-in Connector Type Manifold Cable Type Manifold

P.14



Common Specifications P.3
Construction P.6

D-sub Connector/Flat Ribbon Cable/PC Wiring

How to Order/Connector Type P.15
How to Order/Cable Type P.17
Manifold Electrical Wiring/Connector Type, Cable Type P.19
Dimensions/Connector Type, Cable Type P.21

PC Wiring System with Power Supply Terminal

How to Order/Connector Type P.33
Manifold Electrical Wiring/Connector Type P.35
Dimensions/Connector Type P.36

EX180 Integrated Type (for Output) Serial Transmission System

How to Order/Connector Type P.41
Dimensions/Connector Type P.43

EX510 Gateway System Serial Transmission System

How to Order/Connector Type P.49
Dimensions/Connector Type P.51

Manifold Exploded View/Connector Type, Cable Type

How to Increase Manifold Stations/Connector Type, Cable Type P.56,57

Non plug-in Individual Wiring Manifold

P.60



Individual Wiring

How to Order P.61
Dimensions P.63

Manifold Exploded View/Individual Wiring

..... P.68

Manifold Options P.69

Made to Order P.80

Vacuum Release Valve with Restrictor Series SJ3A6

P.82

Plug-in Connector Type Manifold Cable Type Manifold



Common Specifications P.83

Construction P.84

D-sub Connector/Flat Ribbon Cable/PC Wiring/ Serial Wiring (EX180/EX510)

How to Order/Connector Type P.85
How to Order/Cable Type P.87
Dimensions/Connector Type, Cable Type P.89

Manifold Exploded View/Connector Type, Cable Type

..... P.94,95

Non plug-in Individual Wiring Manifold



Individual Wiring

How to Order P.91
Dimensions P.93

Manifold Exploded View/Individual Wiring



..... P.94

Specific Product Precautions P.96

Manifold Variations

4 Port Solenoid Valve Series SJ2000/3000

Vacuum Release Valve with Restrictor Series SJ3A6

Manifold type			Items	Connection method						Individual wiring
				Parallel wiring				Serial wiring		
			D-sub connector	Flat ribbon cable connector	PC wiring	PC wiring (With power supply terminal)	EX180 (For output)	EX510 (Gateway system)		
4 port solenoid valve	Plug-in	 Connector Type SS5J2/3-60□	● P.15	● P.15	● P.15	● P.33	● P.41	● P.49	● Note 1) P.16 P.34 P.42 P.50	
		 Cable Type New SS5J2/3-60L□	● P.17	● P.17	—	—	—	—	—	
	Non plug-in	 SS5J2/3-60-□	—	—	—	—	—	—	● P.62	
Vacuum release valve with restrictor	Plug-in	 Connector Type SS3J3-60□	● P.85	● P.85	● P.85	● P.85	● P.85	● P.85	● Note 1) P.86	
		 Cable Type New SS3J3-60L□	● P.87	● P.87	—	—	—	—	—	
	Non plug-in	 SS3J3-60-□	—	—	—	—	—	—	● P.91	

Note 1) A linkage printed circuit board is built-into the individual wiring valve so as to combine with the plug-in type.

Note 2) Specify the required specifications in the manifold specification sheet.

Note 3) The all single wiring or all double wiring can be specified.

Note 4) The vacuum release valve uses only the double wiring.

Note 5) Only SJ3000 size is provided.

Note 6) Adding 1 additional station is possible up to the maximum number of stations.

Manifold options											Solenoid valve specifications				
Mixed wiring Single/Double	Mixed type M60 SJ2000/3000	Different pressure pneumatic circuit diagram/ Block disk assembly	Blanking block assembly	Dual flow fitting	Regulator block	SUP/EXH block assembly with regulator and pressure switch	Valve with speed controller	Intermediate connector block assembly	Increase of manifold stations	Voltage suppressor			With individual switch	Main valve fluororubber specifications	
										Non-polar	+/- common Polar	With power saving circuit			
Note 2) ●	P.15 ●	P.69 ●	P.70 ●	P.72 ●	P.73 ●	P.75 ●	P.75 ●	P.79 ●	P.58 ●	●	●	●	●	P.80 ●	
Note 3) —	—	P.69 ●	P.70 ●	P.72 ●	—	—	P.75 ●	—	Note 6) P.59 ●	—	●	●	—	P.80 ●	
●	P.61 ●	P.69 ●	P.70 ●	P.72 ●	P.73 ●	P.75 ●	P.75 ●	—	P.58 ●	—	●	—	—	P.80 ●	
Note 4) —	—	P.69 ●	P.70 ●	—	—	—	—	P.79 ●	P.58 ●	●	●	●	●	P.80 ●	
Note 4) —	—	P.69 ●	P.70 ●	—	—	—	—	—	Note 6) P.59 ●	—	●	●	—	P.80 ●	
Note 4) —	—	P.69 ●	P.70 ●	—	—	—	—	—	P.58 ●	—	●	—	—	P.80 ●	

Common Specifications

Construction

Plug-in

Connector Type/
Cable Type

Non plug-in

Individual Wiring

Manifold Options

Made to Order

SJ3A6

Common Specifications/
Construction

Plug-in

Connector Type/
Cable Type

Non plug-in

Individual Wiring

4 Port Solenoid Valve Series SJ2000/3000

Common Specifications 1



Manifold Specifications

Model	D-sub connector	Flat ribbon cable			Serial wiring		Individual wiring
	Type 60F (Connector type/ Cable type)	Type 60P (Connector type/ Cable type)	Type 60PG (Connector type/ Cable type) Type 60J (Connector type) Type 60G (Connector type)	Type 60PH (Connector type/ Cable type)	Type 60S□ EX180/ (Connector type)	Type 60S6B EX510/ (Connector type)	Type 60
Manifold type	Plug-in, Connector type/Cable type				Plug-in, Connector type		Non plug-in
1(P: SUP), 3/5(E: EXH)	Common SUP, EXH						
Valve stations	Connector type: 1 to 24 stations Cable type: 2 to 20 stations		1 to 18 stations(Type PG) 1 to 16 stations(Type J, Type G)	1 to 8 stations	1 to 32 stations	1 to 16 stations	1 to 20 stations
Applicable connector	D-sub connector Conforming to MIL-C-24308 JIS-X-5101	Flat ribbon cable connector Socket: 26 pins MIL type with strain relief Conforming to MIL-C-83503	Flat ribbon cable connector Socket: 20 pins MIL type with strain relief Conforming to MIL-C-83503	Flat ribbon cable connector Socket: 10 pins MIL type with strain relief Conforming to MIL-C-83503	—	—	—
Internal wiring	Connector type: non-polar, positive common, negative common/Cable type: positive common, negative common						
4(A), 2(B) port piping spec.	Location	Valve					
	Direction	Horizontal, Upward, Downward (Using elbow fittings for upward or downward)					
Port size	1(P), 3/5(E) port	C6, C8, N7, N9 (Inch size elbow fitting is not available.)					
	4(A), 2(B) port	SJ2000	C2, C4, N1, N3, M3				
		SJ3000	C2, C4, C6, N1, N3, N7, M5				
Weight W [g]^[Note 2] (n: Number of SUP/EXH blocks m: Weight of DIN rail)	$W = 51n + m + 133$						

Note 1) When many valves are operated simultaneously, use B type (SUP/EXH both sides), applying pressure to the 1(P) ports on both sides and exhaust from the 3/5(E) ports on both sides.

Note 2) The weight W is the value for the D-sub connector manifold only with internal pilot, SUP/EXH block straight fittings specifications. To obtain the weight with solenoid valves attached, add the solenoid valve weights given on page 5 for the appropriate number of stations. Refer to page 71 for the weight of DIN rail. (Please contact SMC for the weight of external pilot specifications, elbow fittings.)

Flow Characteristics

SJ2000

Port size		Flow characteristics					
1(P) 3/5(E)	4, 2 (A, B)	1→2/4 (P→A/B)			4/2→3/5 (A/B→E)		
		C[dm ³ /(s·bar)]	b	Cv	C[dm ³ /(s·bar)]	b	Cv
C8	C2	0.13	0.55	0.04	0.13	0.50	0.04
	C4	0.33	0.16	0.08	0.36	0.13	0.08
	M3	0.18	0.52	0.06	0.20	0.29	0.06

SJ3000

Port size		Flow characteristics					
1(P) 3/5(E)	4, 2 (A, B)	1→2/4 (P→A/B)			4/2→3/5 (A/B→E)		
		C[dm ³ /(s·bar)]	b	Cv	C[dm ³ /(s·bar)]	b	Cv
C8	C2	0.13	0.56	0.04	0.14	0.51	0.04
	C4	0.42	0.17	0.11	0.45	0.16	0.11
	C6	0.55	0.10	0.12	0.56	0.11	0.12
	M5	0.40	0.28	0.11	0.45	0.15	0.11

Note) The value is for manifold base with 5 stations and individually operated 2 position type.
Please contact SMC for 4 position dual 3 port valves.

Solenoid Valve Specifications

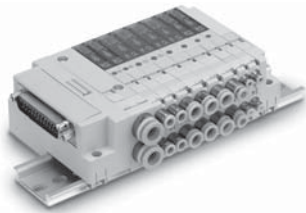
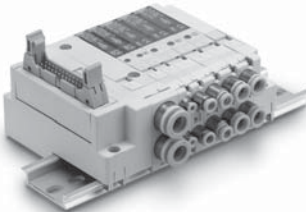
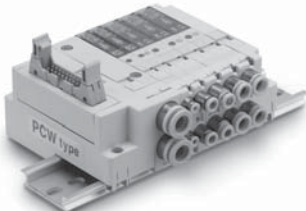
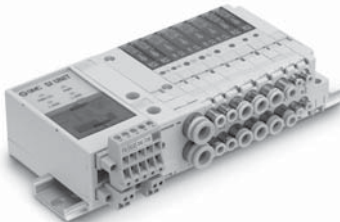
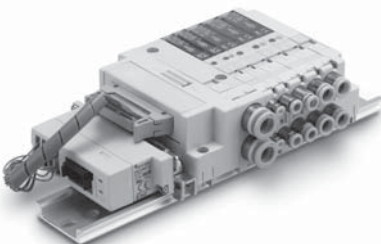
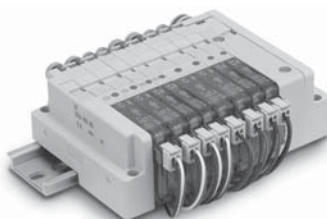
D-sub connector

Flat ribbon cable

PC wiring

**EX180 Integrated type (for output)
serial transmission system**

**EX510 Gateway system
serial transmission system**

Individual wiring

Fluid		Air	
Internal pilot operating pressure range [MPa]	2 position single		0.15 to 0.7
	4 position dual 3 port valve		
	2 position double		0.1 to 0.7
	3 position		0.2 to 0.7
External pilot operating pressure range [MPa]	Operating pressure range		-100 kPa to 0.7
	Pilot pressure range	2 position single	0.25 to 0.7
		2 position double	
		3 position	
Ambient and fluid temperature [°C]		-10 to 50 (No freezing)	
Maximum operating frequency [Hz]	2 position single, double		10
	4 position dual 3 port valve		3
	3 position		
Manual override (Manual operation)		Non-locking push type	
		Push-turn locking slotted type	
Pilot exhaust method	Internal pilot		Main and pilot valve common exhaust
	External pilot		Pilot valve individual exhaust
Lubrication		Not required	
Mounting orientation		Unrestricted	
Impact/Vibration resistance [m/s²]		150/30	
Enclosure		Dustproof	

Note) Impact resistance: No malfunction occurred when it is tested with a drop tester in the axial direction and at the right angles to the main valve and armature in both energised and de-energised states every once for each condition. (Value in the initial state)

Vibration resistance: No malfunction occurred in one sweep test between 45 and 2000Hz. Test was performed to axis and right angle directions of the main valve when pilot signal is ON and OFF. (Value in the initial state)

Solenoid Specifications

Coil rated voltage		24 VDC, 12 VDC	
Allowable voltage fluctuation		±10% of rated voltage*	
Power consumption [W]	Standard	SJ2000	0.55
		SJ3000	0.4
	With power saving circuit (Continuous duty type)	SJ2000	0.23
		SJ3000	0.15
Surge voltage suppressor		Diode	
Indicator light		LED	

* For the allowable voltage fluctuation for Z and T types (with power saving circuit), please observe the following range because they have voltage drop due to internal circuit.

Z type 24 VDC: -7% to +10%
12 VDC: -4% to +10%

T type 24 VDC: -5% to +10%
12 VDC: -6% to +10%

Response Time

Type of actuation	Response time ms (at 0.5 MPa)	
	SJ2000	SJ3000
2 position single	16 or less	16 or less
2 position double	10 or less	10 or less
3 position	34 or less	22 or less
4 position dual 3 port valve	30 or less	30 or less

Note) Based on dynamic performance test, JIS B 8375-1981. (Coil temperature: 20°C, at rated voltage)

4 Port Solenoid Valve

Series SJ2000/3000

Common Specifications 2

Weight

Model/SJ2000

Valve model	Type of actuation		Port size 4(A), 2(B)	Weight [g]
SJ2□60-C2	2 position	Single	C2 (ø2 One-touch fitting)	43
		Double		46
	3 position	Closed centre		50
		Exhaust centre		
		Pressure centre		
4 position	Dual 3 port valve	46		
SJ2□60-C4	2 position	Single	C4 (ø4 One-touch fitting)	41
		Double		44
	3 position	Closed centre		48
		Exhaust centre		
		Pressure centre		
	4 position	Dual 3 port valve		44
SJ2□60-M3	2 position	Single	M3 x 0.5	39
		Double		42
	3 position	Closed centre		46
		Exhaust centre		
		Pressure centre		
	4 position	Dual 3 port valve		42

Note) Please contact SMC for the weight of elbow fittings.

Model/SJ3000

Valve model	Type of actuation		Port size 4(A), 2(B)	Weight [g]
SJ3□60-C2	2 position	Single	C2 (ø2 One-touch fitting)	63
		Double		71
	3 position	Closed centre		75
		Exhaust centre		
		Pressure centre		
4 position	Dual 3 port valve	71		
SJ3□60-C4	2 position	Single	C4 (ø4 One-touch fitting)	65
		Double		73
	3 position	Closed centre		77
		Exhaust centre		
		Pressure centre		
	4 position	Dual 3 port valve		73
SJ3□60-C6	2 position	Single	C6 (ø6 One-touch fitting)	61
		Double		69
	3 position	Closed centre		73
		Exhaust centre		
		Pressure centre		
	4 position	Dual 3 port valve		69
SJ3□60-M5	2 position	Single	M5 x 0.8	57
		Double		65
	3 position	Closed centre		69
		Exhaust centre		
		Pressure centre		
	4 position	Dual 3 port valve		65

Note) Please contact SMC for the weight of elbow fittings.

Connector Wiring Diagram

For both serial and parallel wiring, additional valves are sequentially assigned pins on the connector. This makes it completely unnecessary to disassemble the connector unit.

■ Single solenoid and double solenoid

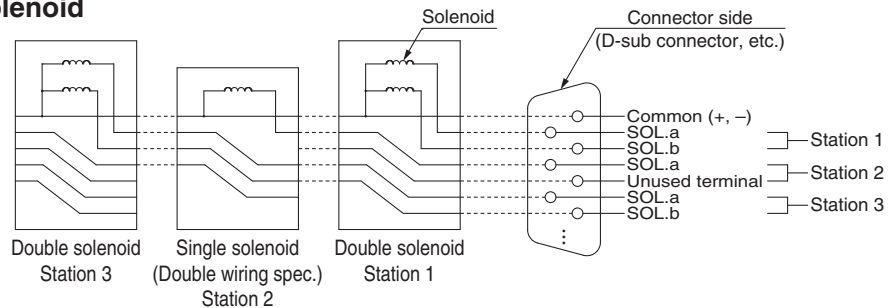

■ Single solenoid with double wiring spec.

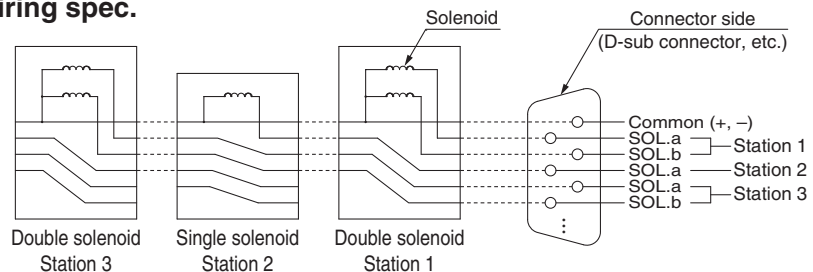

■ Mounting a valve with individual wiring

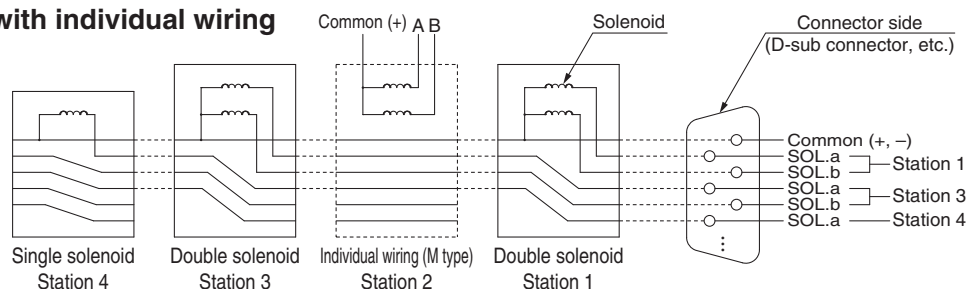

Series SJ2000/3000 Construction 1

SJ2000: Connector Type

Symbol

2 position single

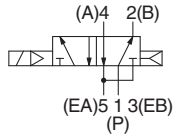

2 position single with back pressure check valve

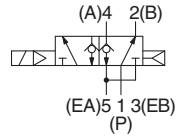

2 position double

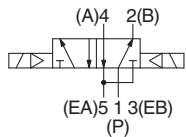

2 position double with back pressure check valve

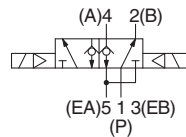

3 position closed centre

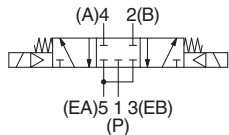

3 position exhaust centre

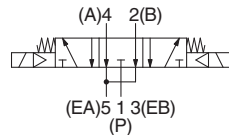

3 position pressure centre

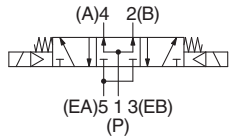

2 position single

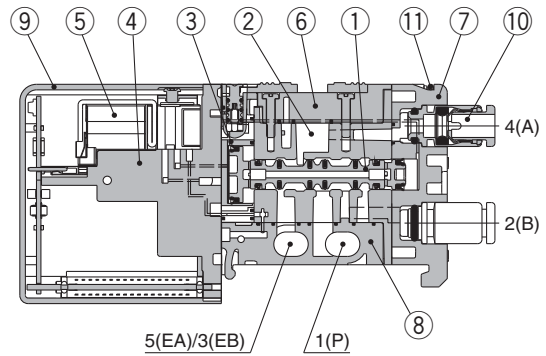

2 position double

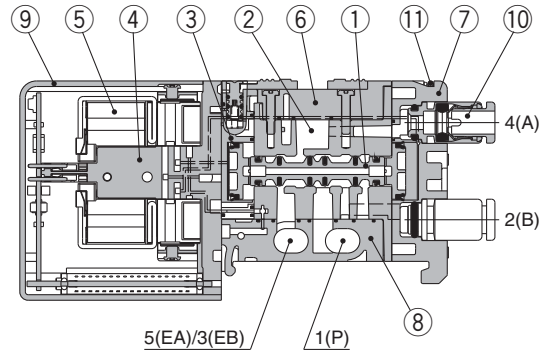

3 position closed centre/exhaust centre/pressure centre

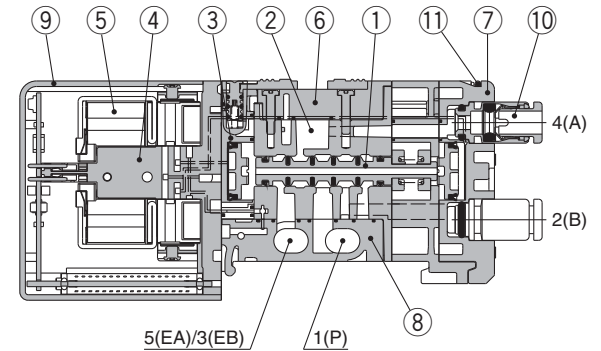

SJ2260K with back pressure check valve

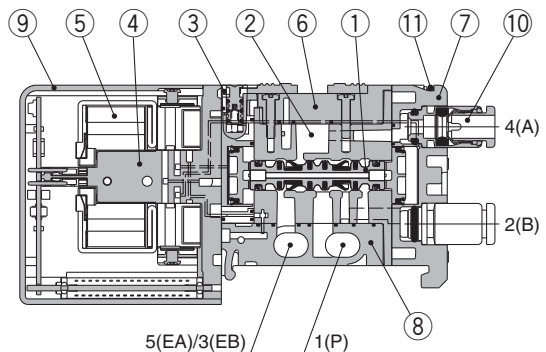

Component Parts

No.	Description	Material	Note
1	Spool valve assembly	Resin/HNBR (3 position solenoid valve: Aluminium/HNBR)	—
2	Body	Zinc die-cast	—
3	Adapter plate	Resin	White
4	Pilot adapter	Resin	White
5	Pilot valve assembly	—	—
6	Body cover	Resin	White
7	Port block	Resin	White
8	Bottom cover	Resin	White
9	Light cover	Resin	Light blue

Replacement Parts

No.	Description	Part no.
10	One-touch fitting	Refer to the One-touch fitting part no. on page 99.
11	Clip	SJ2000-CL-1 (10 pcs.)

SJ
2000
3000

Common
Specifications

Construction

Connector Type/
Cable Type

Plug-in
Non plug-in

Individual
Wiring

Manifold
Options

Made to
Order

SJ3A6

Common Specifications/
Construction

Plug-in
Connector Type/
Cable Type

Non plug-in
Individual
Wiring

Series SJ2000/3000 Construction 2

SJ2000: Connector Type

Symbol

4 position dual 3 port valve
SJ2A60 [N.C. valve x 2]

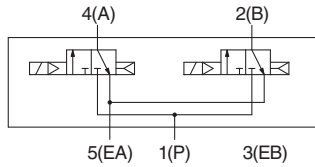

SJ2A60K with back pressure
check valve

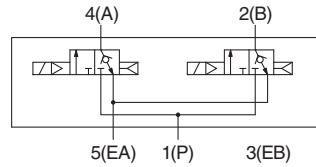

SJ2B60 [N.O. valve x 2]

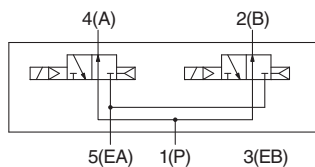

SJ2B60K with back pressure
check valve

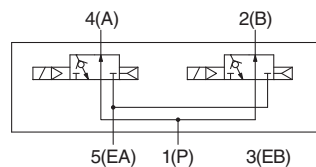

SJ2C60 [N.C., N.O. valve x 1
(each)]

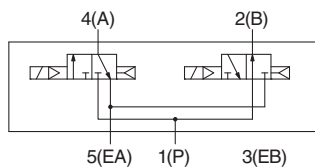

SJ2C60K with back pressure
check valve

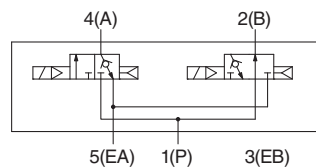

SJ2A60 [N.C. valve x 2]

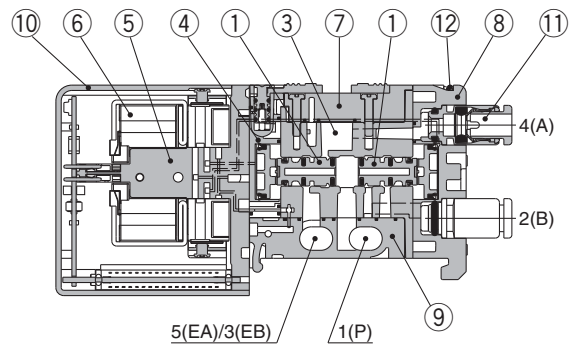

SJ2B60 [N.O. valve x 2]

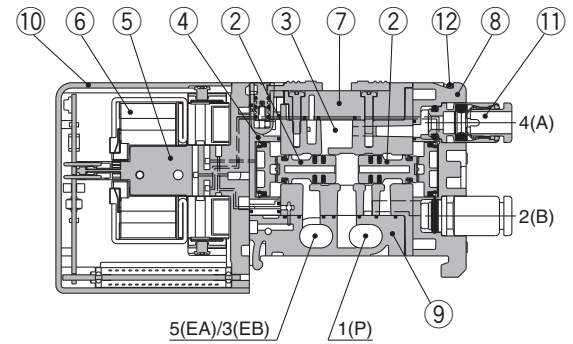

SJ2C60 [N.C. valve, N.O. valve x 1 (each)]

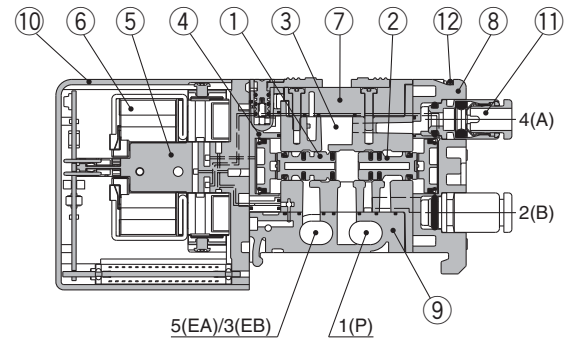

Component Parts

No.	Description	Material	Note
1	Spool valve assembly	Resin/HNBR	N.C. (Normally closed)
2	Spool valve assembly	Resin/HNBR	N.O. (Normally open)
3	Body	Zinc die-cast	—
4	Adapter plate	Resin	White
5	Pilot adapter	Resin	White
6	Pilot valve assembly	—	—
7	Body cover	Resin	White
8	Port block	Resin	White
9	Bottom cover	Resin	White
10	Light cover	Resin	Light blue

Replacement Parts

No.	Description	Part no.
11	One-touch fitting	Refer to the One-touch fitting part no. on page 99.
12	Clip	SJ2000-CL-1 (10 pcs.)

SJ2A60K with back pressure check valve

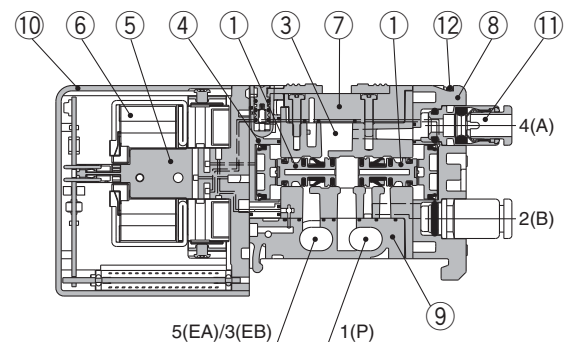

SJ3000: Connector Type

Symbol

2 position single

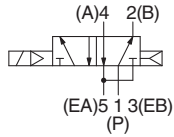

2 position single with back pressure check valve

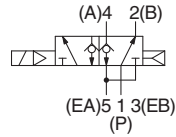

2 position double

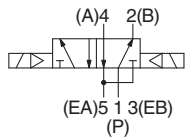

2 position double with back pressure check valve

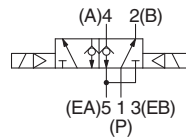

3 position closed centre

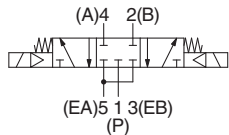

3 position exhaust centre

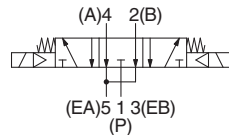

3 position pressure centre

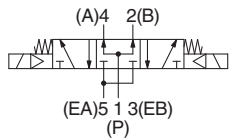

Component Parts

No.	Description	Material	Note
1	Spool valve assembly	Resin/HNBR (3 position solenoid valve: Aluminium/HNBR)	—
2	Body	Zinc die-cast	—
3	Adapter plate	Resin	White
4	Pilot adapter	Resin	White
5	Pilot valve assembly	—	—
6	Body cover	Resin	White
7	Port block	Resin	White
8	Bottom cover	Resin	White
9	Light cover	Resin	Light blue

Replacement Parts

No.	Description	Part no.
10	One-touch fitting	Refer to the One-touch fitting part no. on page 99.
11	Clip	SJ3000-CL-1 (10 pcs.)

2 position single

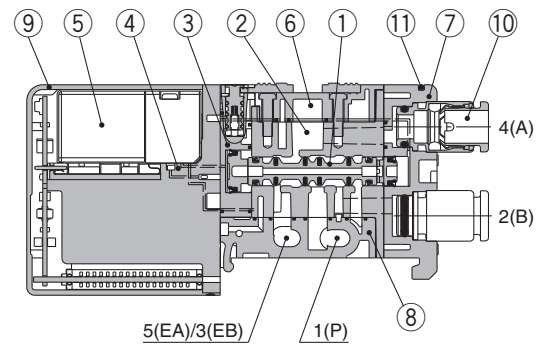

2 position double

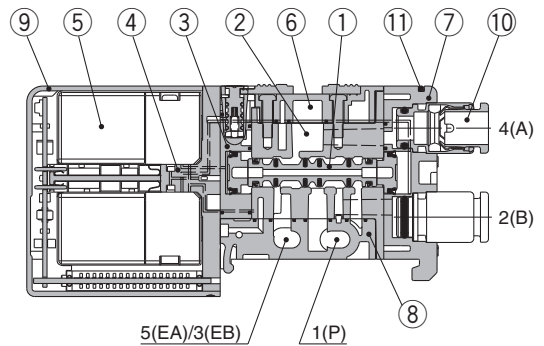

3 position closed centre/exhaust centre/pressure centre

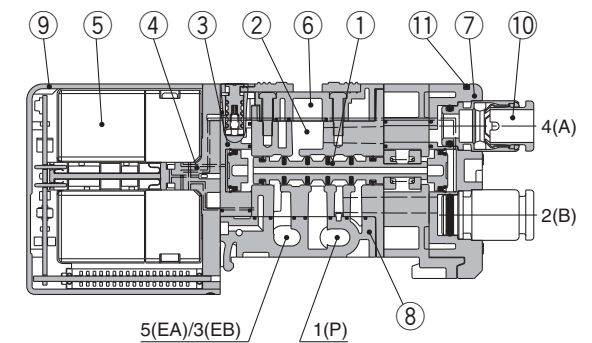

SJ3260K with back pressure check valve

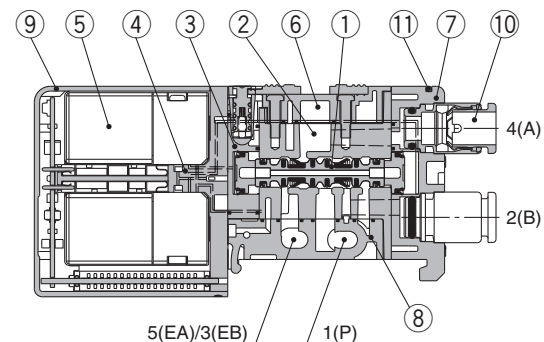

SJ
2000
3000

Common
Specifications

Construction

Connector Type/
Cable Type **Plug-in**

Individual
Wiring **Non plug-in**

Manifold
Options

Made to
Order

SJ3A6

Common Specifications/
Construction

Connector Type/
Cable Type **Plug-in**

Individual
Wiring **Non plug-in**

Series SJ2000/3000 Construction 3

SJ3000: Connector Type

Symbol

4 position dual 3 port valve
SJ3A60 [N.C. valve x 2]

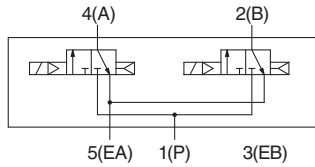

SJ3A60K with back pressure
check valve

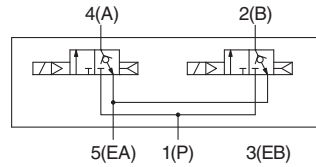

SJ3B60 [N.O. valve x 2]

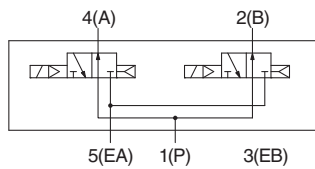

SJ3B60K with back pressure
check valve

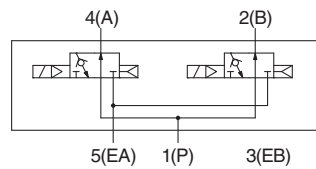

SJ3C60 [N.C., N.O. valve x 1
(each)]

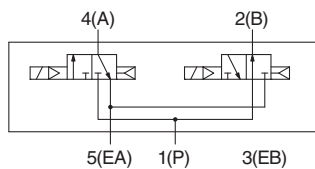

SJ3C60K with back pressure
check valve

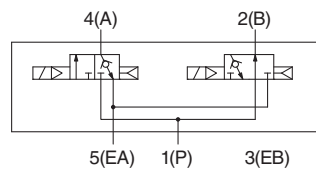

SJ3A60 [N.C. valve x 2]

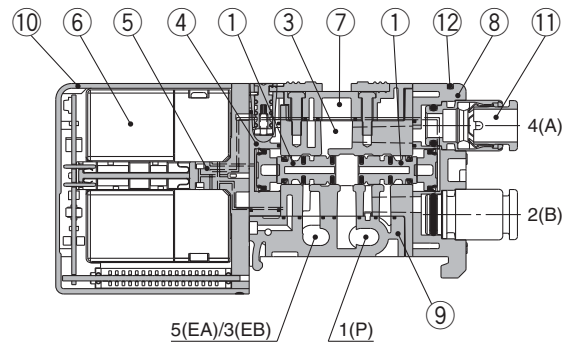

SJ3B60 [N.O. valve x 2]

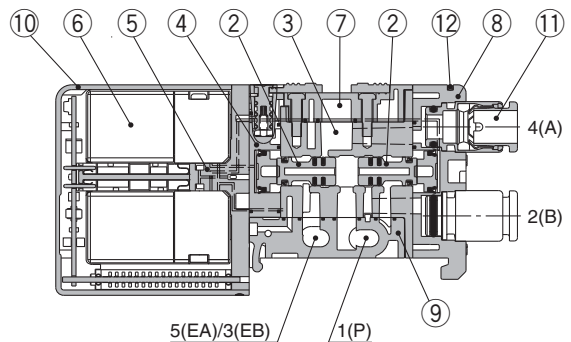

SJ3C60 [N.C. valve, N.O. valve x 1 (each)]

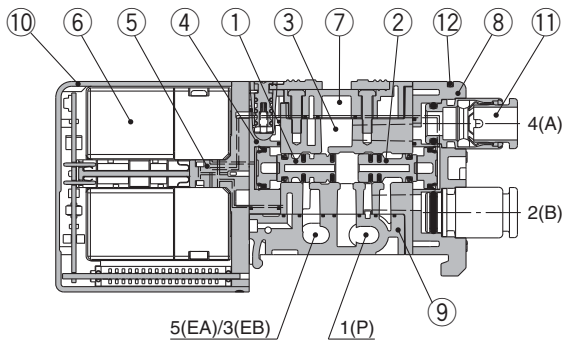

Component Parts

No.	Description	Material	Note
1	Spool valve assembly	Resin/HNBR	N.C. (Normally closed)
2	Spool valve assembly	Resin/HNBR	N.O. (Normally open)
3	Body	Zinc die-cast	—
4	Adapter plate	Resin	White
5	Pilot adapter	Resin	White
6	Pilot valve assembly	—	—
7	Body cover	Resin	White
8	Port block	Resin	White
9	Bottom cover	Resin	White
10	Light cover	Resin	Light blue

Replacement Parts

No.	Description	Part no.
11	One-touch fitting	Refer to the One-touch fitting part no. on page 99.
12	Clip	SJ3000-CL-1 (10 pcs.)

SJ3A60K with back pressure check valve

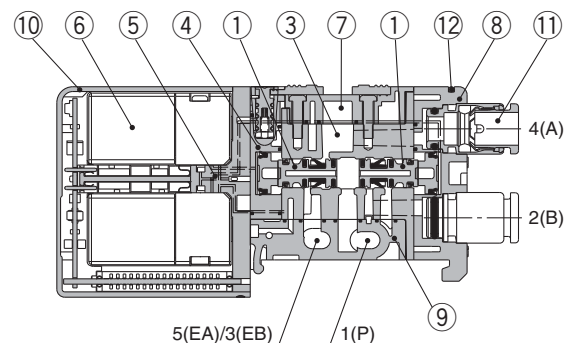

SJ2000: Cable Type

Symbol

2 position single

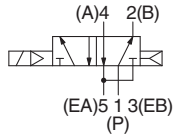

2 position single with back pressure check valve

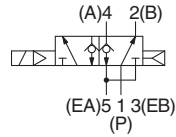

2 position double

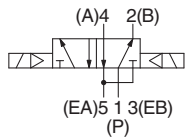

2 position double with back pressure check valve

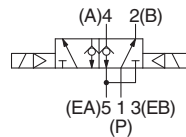

3 position closed centre

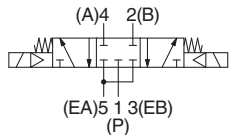

3 position exhaust centre

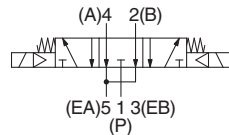

3 position pressure centre

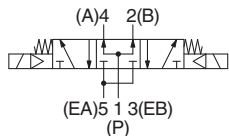

Component Parts

No.	Description	Material	Note
1	Spool valve assembly	Resin/HNBR (3 position solenoid valve: Aluminium/HNBR)	—
2	Body	Zinc die-cast	—
3	Adapter plate	Resin	White
4	Pilot adapter	Resin	White
5	Pilot valve assembly	—	—
6	Body cover	Resin	White
7	Port block	Resin	White
8	Bottom cover assembly	Resin	White
9	Light cover	Resin	Light blue

Replacement Parts

No.	Description	Part no.
10	One-touch fitting	Refer to the One-touch fitting part no. on page 99.
11	Clip	SJ2000-CL-1 (10 pcs.)

2 position single

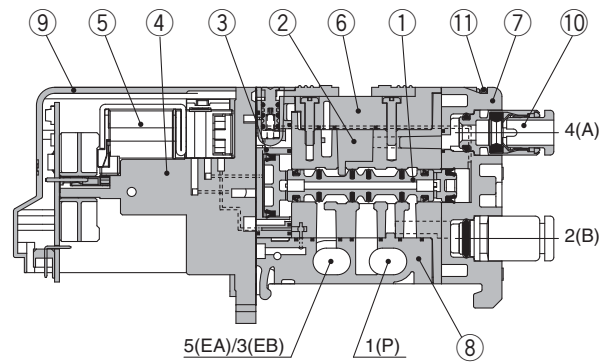

2 position double

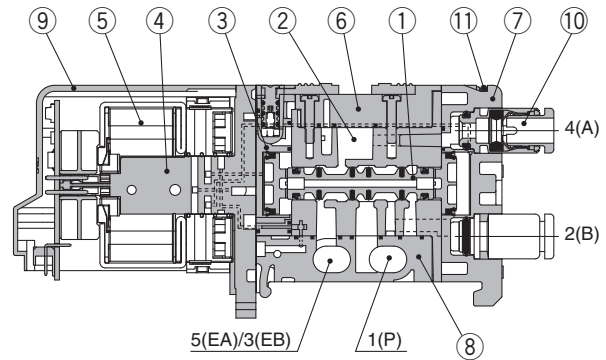

3 position closed centre/exhaust centre/pressure centre

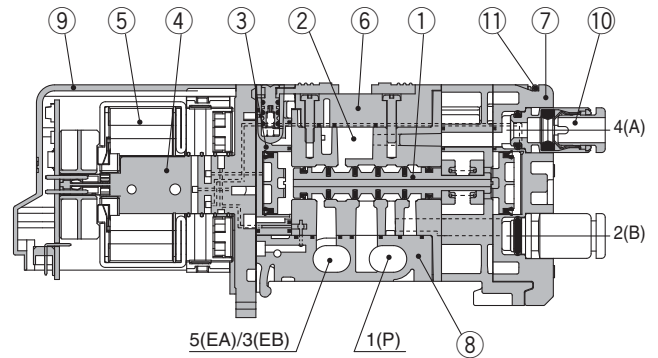

SJ2260K with back pressure check valve

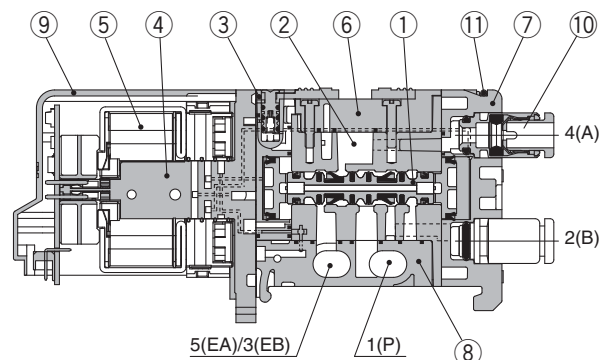

SJ
2000
3000

Common
Specifications

Construction

Connector Type/
Cable Type

Plug-in
Non plug-in

Individual
Wiring

Manifold
Options

Made to
Order

SJ3A6

Common Specifications/
Construction

Plug-in
Connector Type/
Cable Type

Non plug-in
Individual
Wiring

Series SJ2000/3000 Construction 4

SJ2000: Cable Type

Symbol

4 position dual 3 port valve
SJ2A60 [N.C. valve x 2]

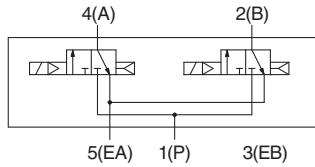

SJ2A60K with back pressure check valve

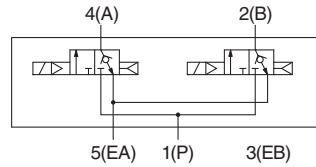

SJ2B60 [N.O. valve x 2]

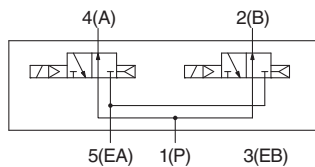

SJ2B60K with back pressure check valve

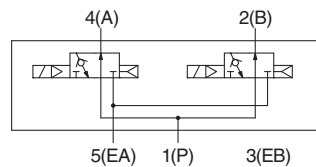

SJ2C60 [N.C., N.O. valve x 1 (each)]

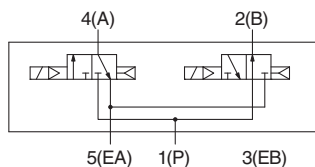

SJ2C60K with back pressure check valve

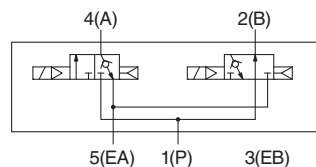

SJ2A60 [N.C. valve x 2]

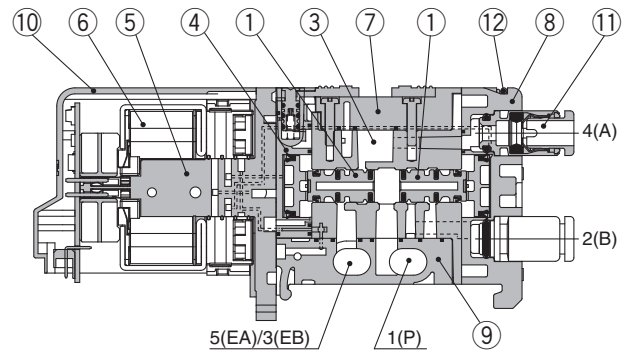

SJ2B60 [N.O. valve x 2]

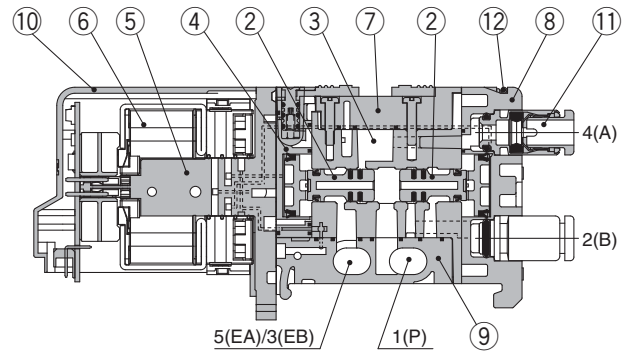

SJ2C60 [N.C. valve, N.O. valve x 1 (each)]

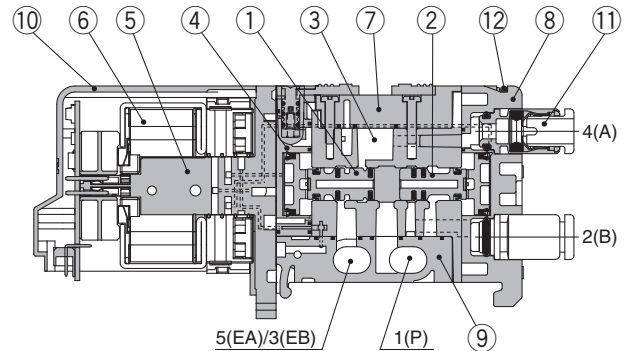

Component Parts

No.	Description	Material	Note
1	Spool valve assembly	Resin/HNBR	N.C. (Normally closed)
2	Spool valve assembly	Resin/HNBR	N.O. (Normally open)
3	Body	Zinc die-cast	—
4	Adapter plate	Resin	White
5	Pilot adapter	Resin	White
6	Pilot valve assembly	—	—
7	Body cover	Resin	White
8	Port block	Resin	White
9	Bottom cover assembly	Resin	White
10	Light cover	Resin	Light blue

Replacement Parts

No.	Description	Part no.
11	One-touch fitting	Refer to the One-touch fitting part no. on page 99.
12	Clip	SJ2000-CL-1 (10 pcs.)

SJ2A60K with back pressure check valve

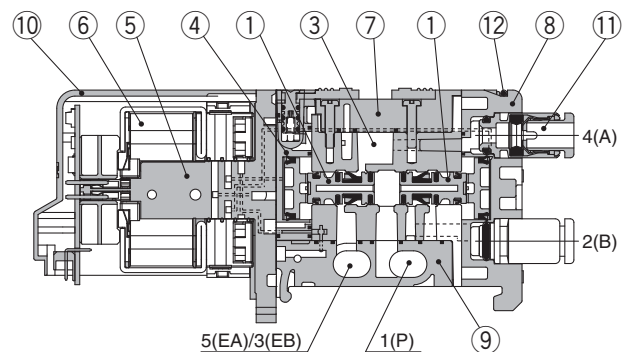

SJ3000: Cable Type

Symbol

2 position single

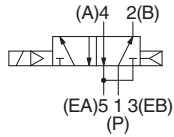

2 position single with
back pressure check valve

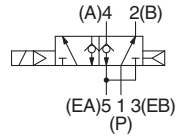

2 position double

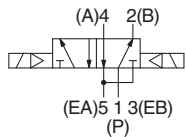

2 position double with
back pressure check valve

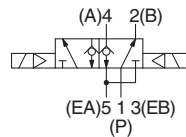

3 position closed centre

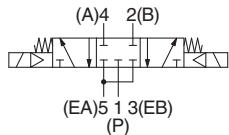

3 position exhaust centre

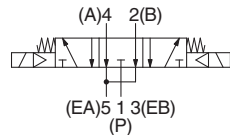

3 position pressure centre

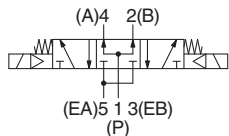

2 position single

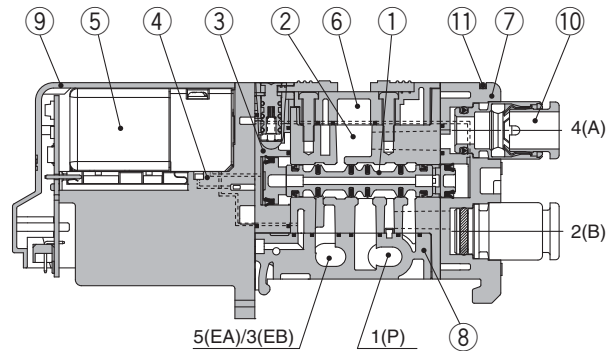

2 position double

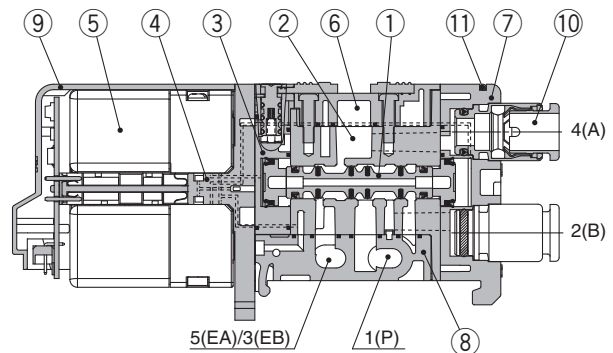

3 position closed centre/exhaust centre/pressure centre

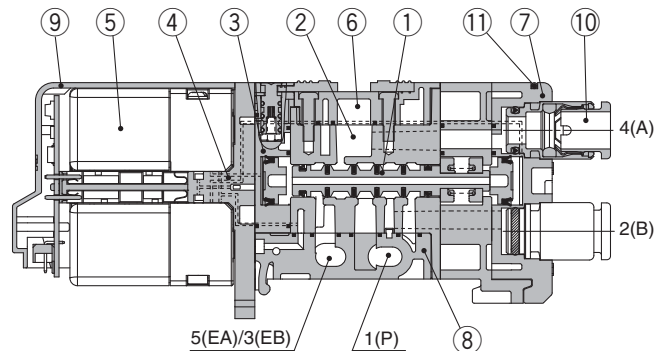

Component Parts

No.	Description	Material	Note
1	Spool valve assembly	Resin/HNBR (3 position solenoid valve: Aluminium/HNBR)	—
2	Body	Zinc die-cast	—
3	Adapter plate	Resin	White
4	Pilot adapter	Resin	White
5	Pilot valve assembly	—	—
6	Body cover	Resin	White
7	Port block	Resin	White
8	Bottom cover assembly	Resin	White
9	Light cover	Resin	Light blue

Replacement Parts

No.	Description	Part no.
10	One-touch fitting	Refer to the One-touch fitting part no. on page 99.
11	Clip	SJ3000-CL-1 (10 pcs.)

SJ3260K with back pressure check valve

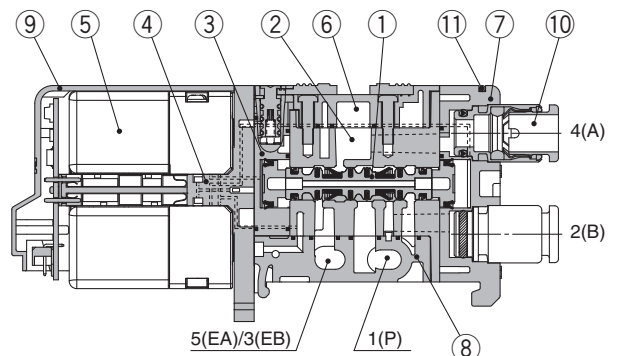

Series SJ2000/3000 Construction 5

SJ3000: Cable Type

Symbol

4 position dual 3 port valve
SJ3A60 [N.C. valve x 2]

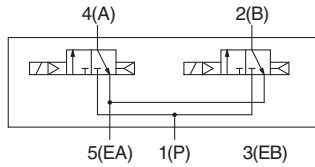

SJ3A60K with back pressure
check valve

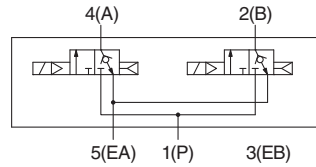

SJ3B60 [N.O. valve x 2]

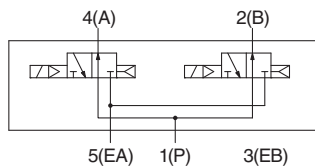

SJ3B60K with back pressure
check valve

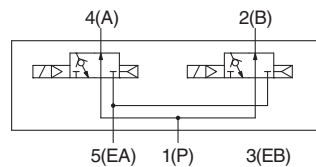

SJ3C60 [N.C., N.O. valve x 1
(each)]

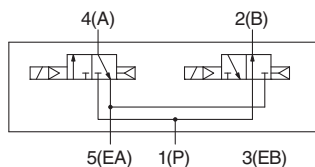

SJ3C60K with back pressure
check valve

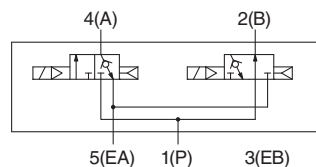

SJ3A60 [N.C. valve x 2]

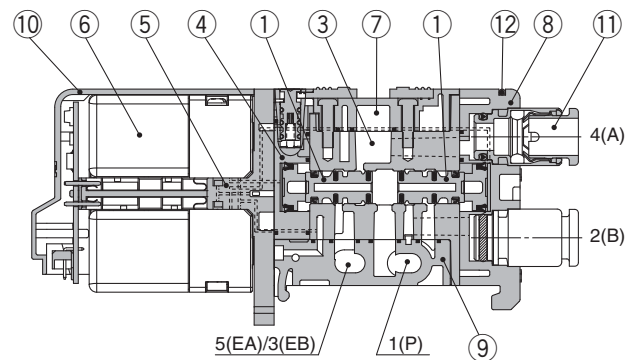

SJ3B60 [N.O. valve x 2]

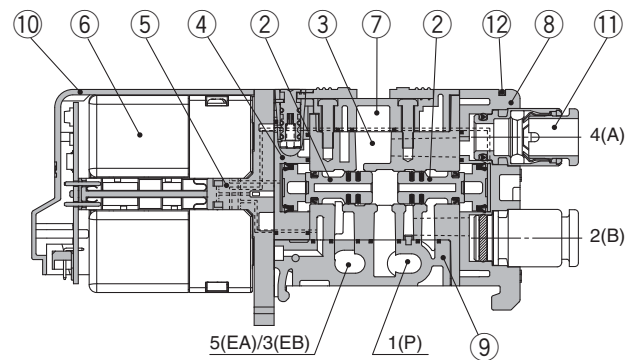

SJ3C60 [N.C. valve, N.O. valve x 1 (each)]

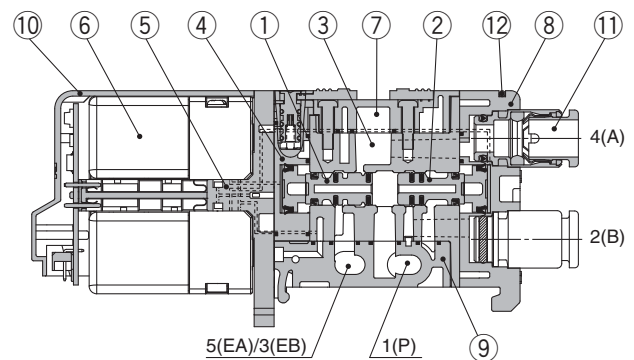

Component Parts

No.	Description	Material	Note
1	Spool valve assembly	Resin/HNBR	N.C. (Normally closed)
2	Spool valve assembly	Resin/HNBR	N.O. (Normally open)
3	Body	Zinc die-cast	—
4	Adapter plate	Resin	White
5	Pilot adapter	Resin	White
6	Pilot valve assembly	—	—
7	Body cover	Resin	White
8	Port block	Resin	White
9	Bottom cover assembly	Resin	White
10	Light cover	Resin	Light blue

Replacement Parts

No.	Description	Part no.
11	One-touch fitting	Refer to the One-touch fitting part no. on page 99.
12	Clip	SJ3000-CL-1 (10 pcs.)

SJ3A60K with back pressure check valve

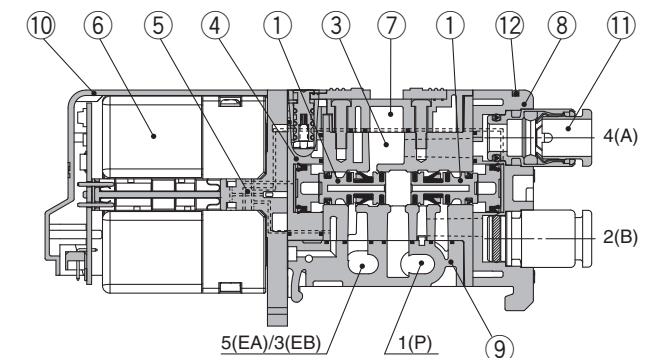

Plug-in Connector Type Manifold Cable Type Manifold

Series *SJ2000/3000*

P.15

Connector Type Manifold
D-sub Connector/Flat Ribbon Cable/PC Wiring

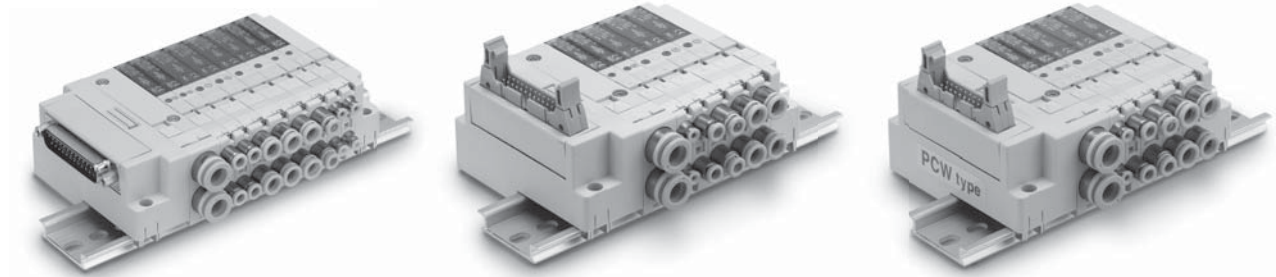

P.17

Cable Type Manifold
D-sub Connector/Flat Ribbon Cable

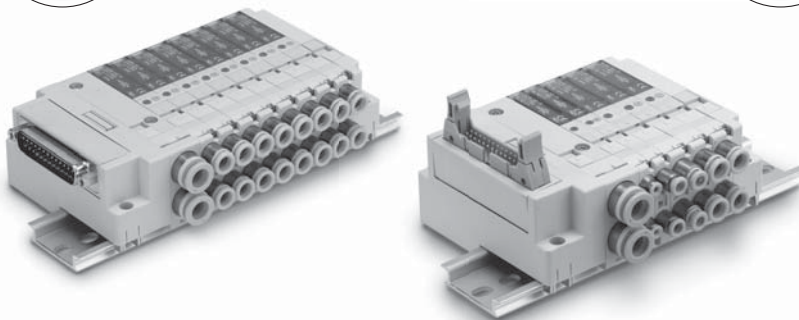

P.33

Connector Type Manifold
PC Wiring System with
Power Supply Terminal

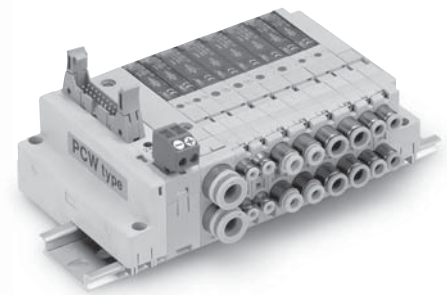

P.41

Connector Type Manifold
EX180 Integrated Type (for
Output) Serial Transmission
System

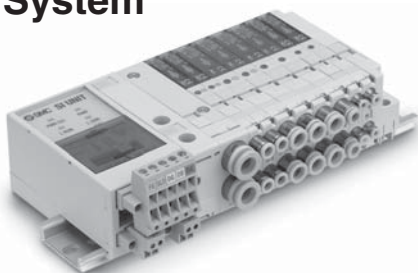

P.49

Connector Type Manifold
EX510 Gateway System
Serial Transmission System

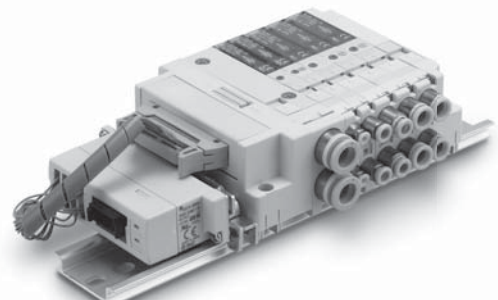

SJ
2000
3000

Common
Specifications

Construction

Connector Type/
Cable Type

Plug-in

Non plug-in

Individual
Wiring

Manifold
Options

Made to
Order

SJ3A6

Common Specifications/
Construction

Plug-in

Connector Type/
Cable Type

Non plug-in

Individual
Wiring

D-sub Connector/Flat Ribbon Cable/ PC Wiring

Series SJ2000/3000

An order cannot be placed with only the manifold part no. Be sure to order solenoid valves for mounting at the same time while referring to the ordering example.

How to Order

● Connector type manifold

SS5J 3 - 60 F D 1 - 05 U

2	SJ2000
3	SJ3000 (SJ2000/3000 mixed)

● DIN rail length specified

—	Standard length	
2	2 stations	Specify a longer rail than the standard length.
⋮	⋮	
24	24 stations	

* Specify the valve stations not exceeding the maximum stations.

Mixed mounting type

—	Standard <small>Note 1)</small>
M	Mixed mounting <small>Note 2)</small>

Note 1) There is no need to enter anything when you operate either the SJ2000 or SJ3000 series alone.
Note 2) Enter "M" when the SJ2000 or SJ3000 series will be mounted on the same manifold base together.

Connector mounting position

Symbol	Mounting position
D	D side

Connector entry direction

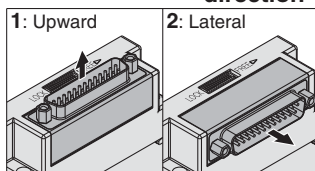

● SUP/EXH block fitting spec.

—	Straight fitting	
—	With external pilot spec. X, PE port	
L	Elbow fitting (Upward) With external pilot spec. X, PE port	
B	Elbow fitting (Downward) With external pilot spec. X, PE port	

* There is no need to enter anything when the SUP/EXH block mounting position "M" is selected.

Connector type

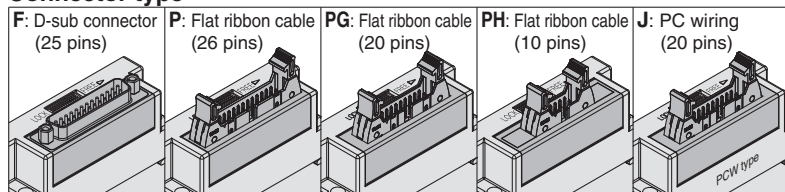

How to Order Manifold Assembly

Ordering example (SS5J3-60PD2-□)

Double solenoid, individual wiring/lead wire length 300 mm (24 VDC)
SJ3260-5MZ-C6 (1 set)

Double solenoid, with switch (24 VDC)
SJ3260-5CZJ-C6 (1 set)

Double solenoid (24 VDC)

SJ3260-5CU-C6 (2 sets)

Single solenoid (24 VDC)

SJ3160-5CU-C6 (2 sets)

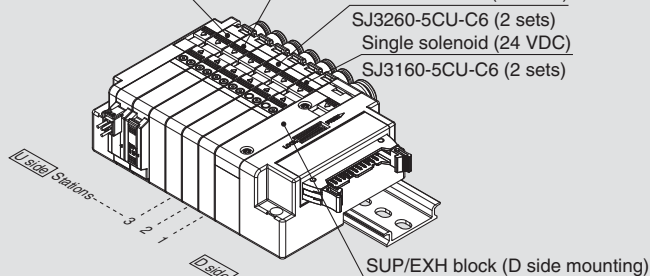

SS5J3-60PD2-06D ... 1 set (Manifold part no.)

* SJ3160-5CU-C6 2 sets (Single solenoid part no.)

* SJ3260-5CU-C6 2 sets (Double solenoid part no.)

* SJ3260-5CZJ-C6 1 set (Double solenoid, with switch part no.)

* SJ3260-5MZ-C6 1 set (Double solenoid, individual wiring/lead wire length 300 mm part no.)

→ The asterisk denotes the symbol for assembly.
Prefix to the part no. of the solenoid valve, etc.

- The valve arrangement is numbered as the 1st station from D side.
- Indicate the valves to be attached below the manifold part number, in order starting from station 1 as shown in the drawing. In the case of complex arrangement, specify them in the manifold specification sheet.

Note) When ordering a manifold, specify the part nos. of valves to be mounted together.
(An order cannot be placed with only the manifold part no.)

● Pilot spec.

—	Internal pilot
S	Internal pilot/Built-in silencer
R	External pilot
RS	External pilot/Built-in silencer

* There is no need to enter anything when the SUP/EXH block mounting position "M" is selected.

* For built-in silencers, the 3/5(E) ports are plugged.

● SUP/EXH block mounting position

U	U side (1 to 10 stations)
D	D side (1 to 10 stations)
B	Both sides (1 to 24 stations)
M*	Special specifications

* Specify the required specifications (including port sizes other than ø8) by means of the manifold specification sheet.

● Valve stations

F: D-sub connector

Symbol	Stations	Note
01	1 station	Up to 24 solenoids possible.
⋮	⋮	
24	24 stations	

P: Flat ribbon cable (26 pins)

Symbol	Stations	Note
01	1 station	Up to 24 solenoids possible.
⋮	⋮	
24	24 stations	

PG: Flat ribbon cable (20 pins)

Symbol	Stations	Note
01	1 station	Up to 18 solenoids possible.
⋮	⋮	
18	18 stations	

PH: Flat ribbon cable (10 pins)

Symbol	Stations	Note
01	1 station	Up to 8 solenoids possible.
⋮	⋮	
08	8 stations	

J: PC wiring (20 pins)

Symbol	Stations	Note
01	1 station	Up to 16 solenoids possible.
⋮	⋮	
16	16 stations	

* The number of the blanking block assembly is also included. Since single and double wiring are available with the blanking block assembly, select a model compatible with the valve wiring spec. planned for the future. (Refer to page 70.)

🔍 * Refer to page 33 through to 40 for PC wiring type with power supply terminal.

How to Order Solenoid Valves

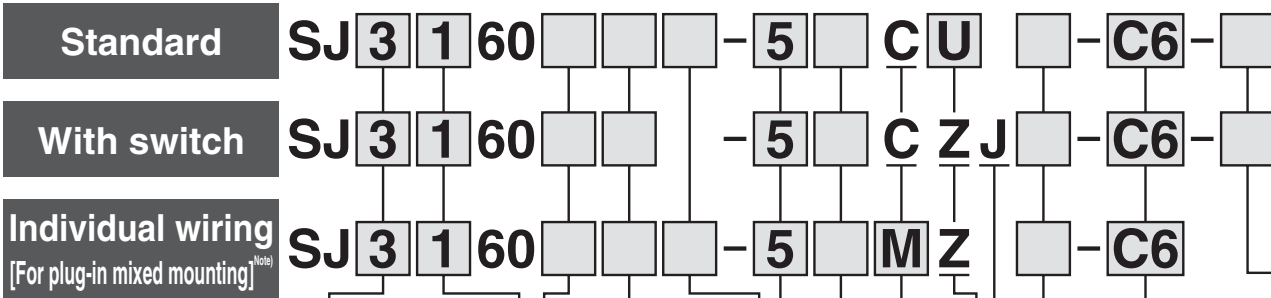

Note) Refer to pages 61 and 62 for the dedicated non plug-in individual wiring.

Series

2	SJ2000
3	SJ3000

Back pressure check valve

—	None
K	Built-in

Rated voltage

5	24 VDC
6	12 VDC

Single solenoid wiring spec.

—	Single wiring
D	Double wiring

* There is no need to enter anything for 2 position double, 3 position and 4 position solenoid valves. Select this when the unused numbers to wiring are set. Refer to page 5 for details.

Type of actuation

1	2 position single solenoid
2	2 position double solenoid
3	3 position closed centre
4	3 position exhaust centre
5	3 position pressure centre
A	Dual 3 port valve: N.C./N.C.
B	Dual 3 port valve: N.O./N.O.
C	Dual 3 port valve: N.C./N.O.

Pilot spec.

—	Internal pilot
R	External pilot

* External pilot spec. is not applicable for 4 position dual 3 port valves.

Common specifications

—	Positive common
N	Negative common

* For the non-polar type, there is no need to select a symbol.

* Refer to pages 6 through to 13 for the Symbol.

Coil spec.

—	Standard
T	With power saving circuit (Continuous duty type)

* Be sure to select "with power saving circuit" when the solenoid valve will be energised continuously for long period.

Light/surge voltage suppressor

U	With light/surge voltage suppressor (Non-polar type)
Z	With light/surge voltage suppressor (Polar type)

* When the types with power saving circuit, with switches, and individual wiring are used, the non-polar type cannot be selected.

Connector entry

C: Dedicated for centralised wiring

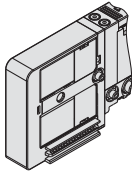

M: Individual wiring, With lead wire Length 300 mm

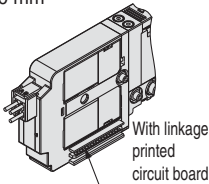

MN: Individual wiring, Without lead wire (With connector, socket)

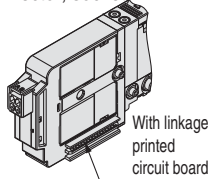

MO: Individual wiring, Without connector

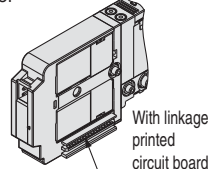

* Connector entries with the symbol "M□" can not use the switch signal from the common wiring on the manifold. For details, refer to "Connector Wiring Diagram" on page 5.
 * When ordering a connector assembly separately, refer to pages 101 and 102.

With switch

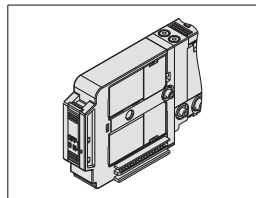

Manual override

—: Non-locking push type

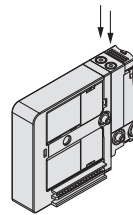

D: Push-turn locking slotted type

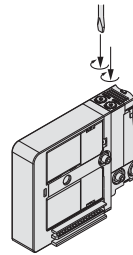

F: Slide locking type

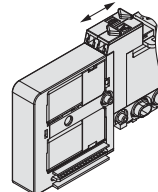

A, B port size

Straight (Metric size)

- C2: ø2 One-touch fitting
- C4: ø4 One-touch fitting
- C6: ø6 One-touch fitting (SJ3000 only)

(Inch size)

- N1: ø1/8" One-touch fitting
- N3: ø5/32" One-touch fitting
- N7: ø1/4" One-touch fitting (SJ3000 only)

- M3: M3 x 0.5 (SJ2000 only)
- M5: M5 x 0.8 (SJ3000 only)

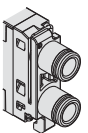

Elbow fitting assembly (Upward entry) (Metric size)

- L2: ø2 elbow fitting assembly
- L4: ø4 elbow fitting assembly
- L6: ø6 elbow fitting assembly (SJ3000 only)

(Inch size)

- LN1: ø1/8" elbow fitting assembly
- LN3: ø5/32" elbow fitting assembly
- LN7: ø1/4" elbow fitting assembly (SJ3000 only)

Elbow fitting assembly (Downward entry) (Metric size)

- B2: ø2 elbow fitting assembly
- B4: ø4 elbow fitting assembly
- B6: ø6 elbow fitting assembly (SJ3000 only)

(Inch size)

- BN1: ø1/8" elbow fitting assembly
- BN3: ø5/32" elbow fitting assembly
- BN7: ø1/4" elbow fitting assembly (SJ3000 only)

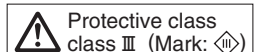
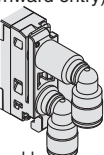
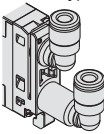

SJ
2000
3000

Common
Specifications

Construction

Plug-in

Connector Type/
Cable Type

Non plug-in

Individual
Wiring

Manifold
Options

Made to
Order

SJ3A6

Common Specifications/
Construction

Plug-in

Connector Type/
Cable Type

Non plug-in

Individual
Wiring

Plug-in Cable Type



D-sub Connector/Flat Ribbon Cable

Series SJ2000/3000

An order cannot be placed with only the manifold part no. Be sure to order solenoid valves for mounting at the same time while referring to the ordering example.

How to Order

● Cable type manifold

SS5J **3** - **60L** **F** **D** **1** - **05** **U** **U** **U**

Series

2	SJ2000
3	SJ3000

Cable type

DIN rail length specified

—	Standard length	
3	3 stations	Specify a longer rail than the standard length.
⋮	⋮	
20	20 stations	

* Specify the valve stations not exceeding the maximum stations.

Connector mounting position

Symbol	Mounting position
D	D side

Connector entry direction

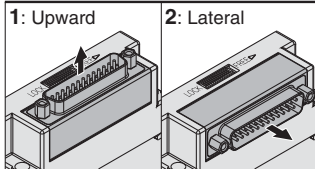

● SUP/EXH block fitting spec.

—	Straight fitting With external pilot spec. X, PE port: Elbow fitting	
L	Elbow fitting (Upward) With external pilot spec. X, PE port: Straight fitting	
B	Elbow fitting (Downward) With external pilot spec. X, PE port: Elbow fitting	

* There is no need to enter anything when the SUP/EXH block mounting position "M" is selected.

● Connector type

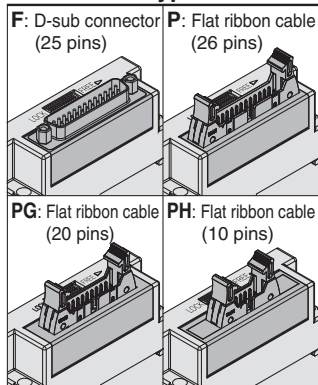

Manifold wiring spec.

—	All double wiring <small>Note 1)</small>
S	All single wiring <small>Note 2)</small>

Note 1) All double wiring: 2-position single, double, 3-position and 4-position valves can be used on all manifold stations.

Note 2) All single wiring: Available only for the manifold which has 2-position single for all stations. Note that 2-position double, 3- or 4-position valves cannot be used.

Note 3) If a mixture of single wiring and double wiring is required, it is available as a special order.

How to Order Manifold Assembly

Ordering example (SS5J3-60LPD2)

Double solenoid (24 VDC)
SJ3260-5FZ-C6 (4 sets)
Single solenoid (24 VDC)
SJ3160-5FZ-C6 (2 sets)

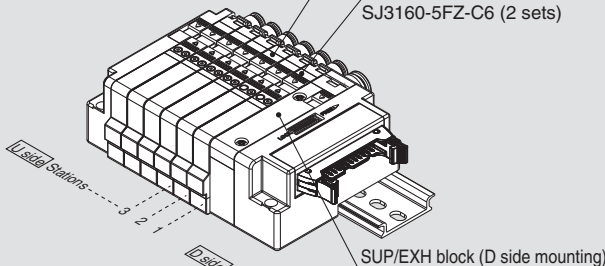

SS5J3-60LPD2-06D ... 1 set (Manifold part no.)
* **SJ3160-5FZ-C6** 2 sets (Single solenoid part no.)
* **SJ3260-5FZ-C6** 4 sets (Double solenoid part no.)

The asterisk denotes the symbol for assembly. Prefix to the part no. of the solenoid valve, etc.

- The valve arrangement is numbered as the 1st station from D side.
- Indicate the valves to be attached below the manifold part number, in order starting from station 1 as shown in the drawing. In the case of complex arrangement, specify them in the manifold specification sheet.

Note) When ordering a manifold, specify the part nos. of valves to be mounted together. (An order cannot be placed with only the manifold part no.)

SUP/EXH block mounting position

U	U side (2 to 10 stations)
D	D side (2 to 10 stations)
B	Both sides (2 to 20 stations)
M*	Special specifications

* Specify the required specifications (including port sizes other than ø8) by means of the manifold specification sheet.

● Pilot spec.

—	Internal pilot
S	Internal pilot/ Built-in silencer
R	External pilot
RS	External pilot/ Built-in silencer

* There is no need to enter anything when the SUP/EXH block mounting position "M" is selected.

● Valve stations

F: D-sub connector (25 pins)			P: Flat ribbon cable (26 pins)			PG: Flat ribbon cable (20 pins)		
Symbol	Stations	Note	Symbol	Stations	Note	Symbol	Stations	Note
02	2 stations	All	02	2 stations	All	02	2 stations	All
⋮	⋮	double wiring	⋮	⋮	double wiring	⋮	⋮	double wiring
10	10 stations	All	10	10 stations	All	09	9 stations	All
02	2 stations	All	02	2 stations	All	02	2 stations	All
⋮	⋮	single wiring	⋮	⋮	single wiring	⋮	⋮	single wiring
20	20 stations	All	20	20 stations	All	18	18 stations	All

PH: Flat ribbon cable (10 pins)

Symbol	Stations	Note
02	2 stations	All
⋮	⋮	double wiring
04	4 stations	All
02	2 stations	All
⋮	⋮	single wiring
08	8 stations	All

* The number of the blanking block assembly is also included.

* The cable type is applicable to 2 or more stations.

How to Order Solenoid Valves

SJ 3 1 60 - 5 FZ - C6

Series

2	SJ2000
3	SJ3000

Type of actuation

1	2 position single solenoid
2	2 position double solenoid
3	3 position closed centre
4	3 position exhaust centre
5	3 position pressure centre
A	Dual 3 port valve: N.C./N.C.
B	Dual 3 port valve: N.O./N.O.
C	Dual 3 port valve: N.C./N.O.

* Refer to pages 6 through to 13 for the Symbol.

Pilot spec.

—	Internal pilot
R	External pilot

* External pilot spec. is not applicable for 4 position dual 3 port valves.

Back pressure check valve

—	None
K	Built-in

* Back pressure check valve is not applicable for 3 position valve.

Coil spec.

—	Standard
T	With power saving circuit (Continuous duty type)

* Be sure to select "with power saving circuit" when the solenoid valve will be energised continuously for long period.

Rated voltage

5	24 VDC
6	12 VDC

Common specifications

—	Positive common
N	Negative common

Connector entry

F: Dedicated for centralised wiring, cable type

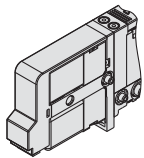

Light/surge voltage suppressor

Z	With light/surge voltage suppressor
---	-------------------------------------

Manual override

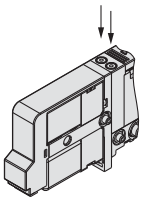
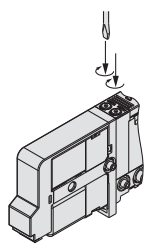
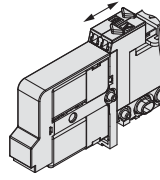
<p>—: Non-locking push type</p> 	<p>D: Push-turn locking slotted type</p> 	<p>F: Slide locking type</p> 
---	---	--

A, B port size

Straight (Metric size)
C2: ø2 One-touch fitting
C4: ø4 One-touch fitting (SJ3000 only)
C6: ø6 One-touch fitting (SJ3000 only)

(Inch size)
N1: ø1/8" One-touch fitting
N3: ø5/32" One-touch fitting
N7: ø1/4" One-touch fitting (SJ3000 only)

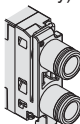

M3: M3 x 0.5 (SJ2000 only)
M5: M5 x 0.8 (SJ3000 only)

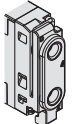

Elbow fitting (Upward entry) (Metric size)
L2: ø2 elbow fitting
L4: ø4 elbow fitting (SJ3000 only)
L6: ø6 elbow fitting (SJ3000 only)

(Inch size)
LN1: ø1/8" elbow fitting
LN3: ø5/32" elbow fitting
LN7: ø1/4" elbow fitting (SJ3000 only)

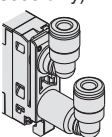

Elbow fitting (Downward entry) (Metric size)
B2: ø2 elbow fitting
B4: ø4 elbow fitting (SJ3000 only)
B6: ø6 elbow fitting (SJ3000 only)

(Inch size)
BN1: ø1/8" elbow fitting
BN3: ø5/32" elbow fitting
BN7: ø1/4" elbow fitting (SJ3000 only)

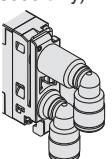
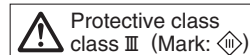
SJ
2000
3000

Common Specifications

Construction

Plug-in
Connector Type/
Cable Type

Non plug-in
Individual Wiring

Manifold Options

Made to Order

SJ3A6

Common Specifications/
Construction

Plug-in
Connector Type/
Cable Type

Non plug-in
Individual Wiring

Manifold Electrical Wiring/Connector Type (Non-polar Type)

Type 60F: D-sub connector (25 pins)

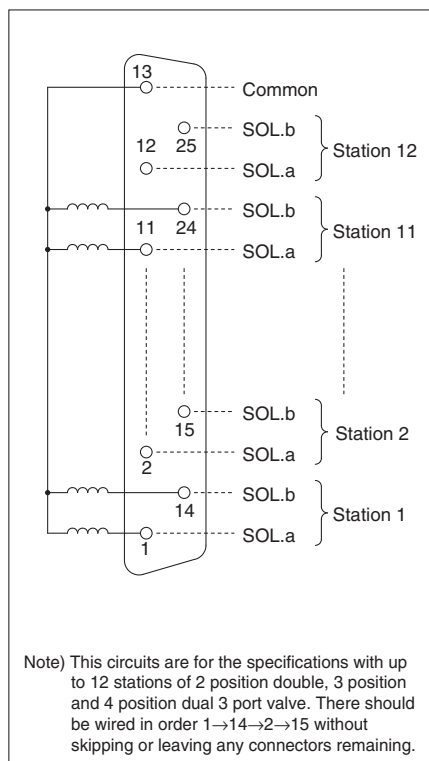

Type 60P: Flat ribbon cable (26 pins)

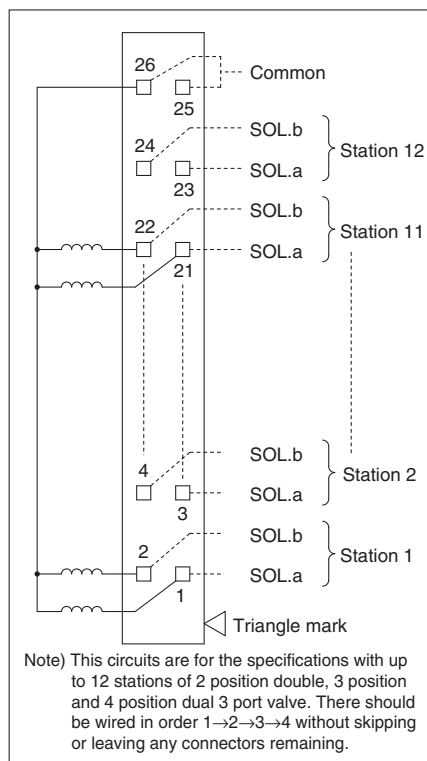

Type 60PG: Flat ribbon cable (20 pins)

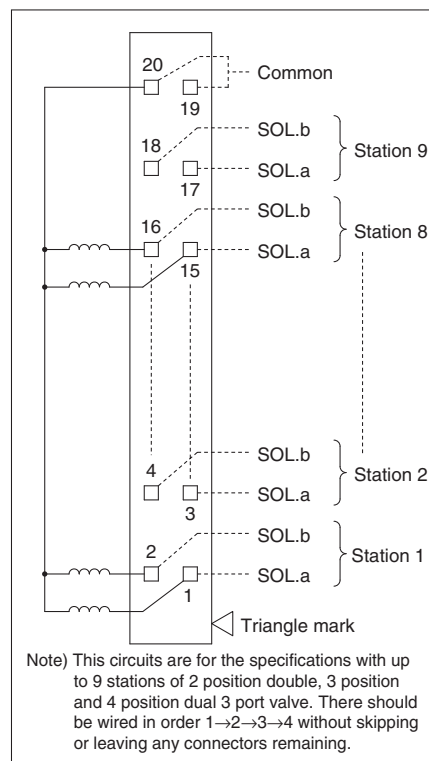

Type 60PH: Flat ribbon cable (10 pins)

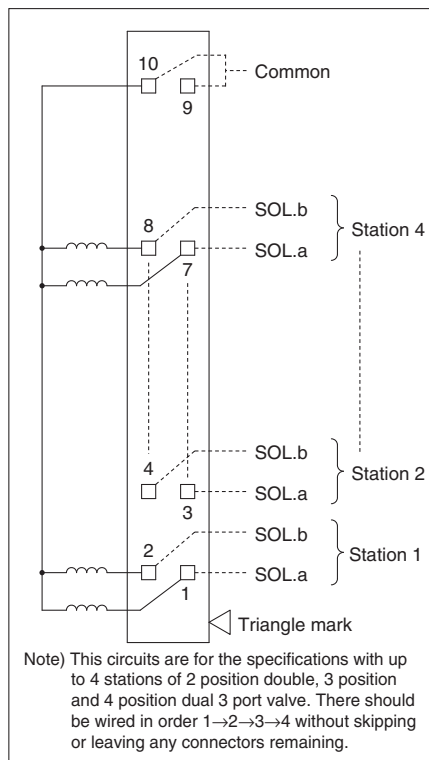

Type 60J: Flat ribbon cable (20 pins, PC wiring)

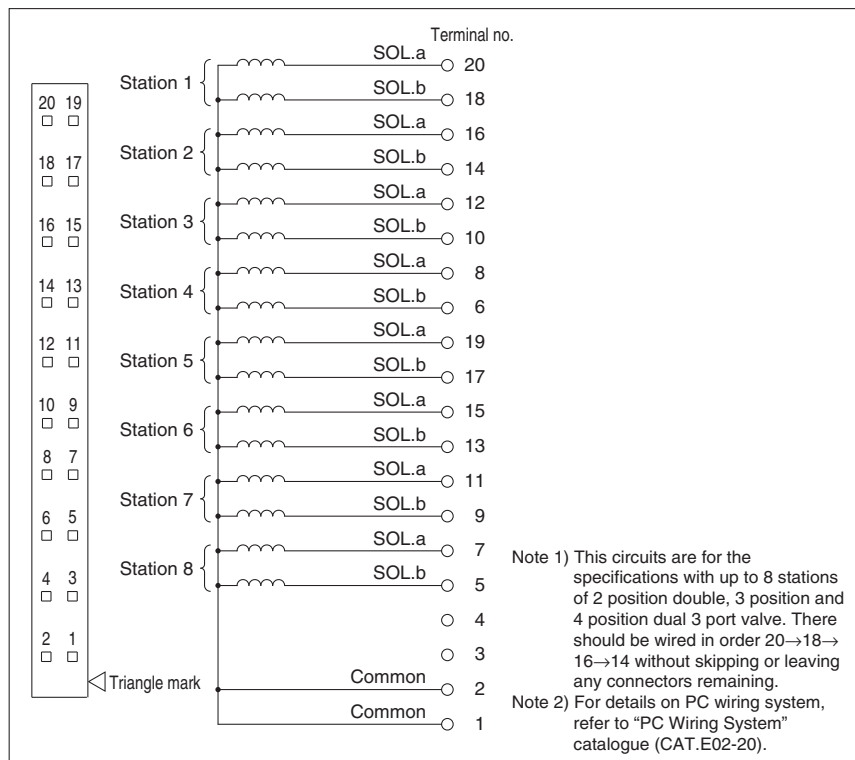

⚠ Caution

When the non-polar U type valves are used, either positive common or negative common wiring of the manifold is possible. However, when the Z type valves are used, select the positive common or negative common according to the wiring specifications.

Manifold Electrical Wiring/Cable Type

Type 60LF: D-sub connector (25 pins)

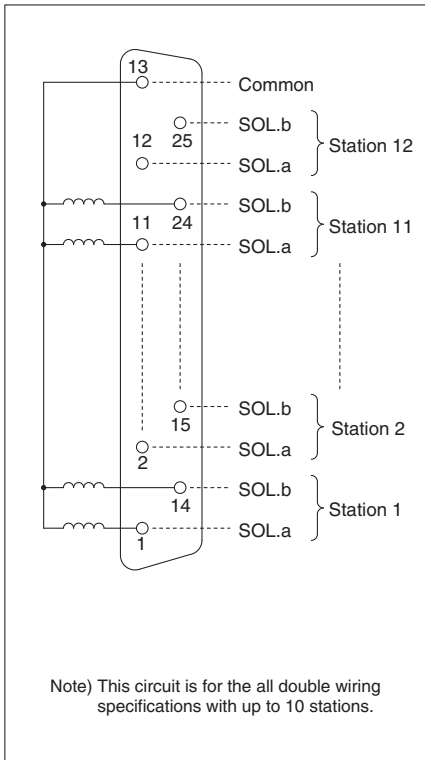

Type 60LP: Flat ribbon cable (26 pins)

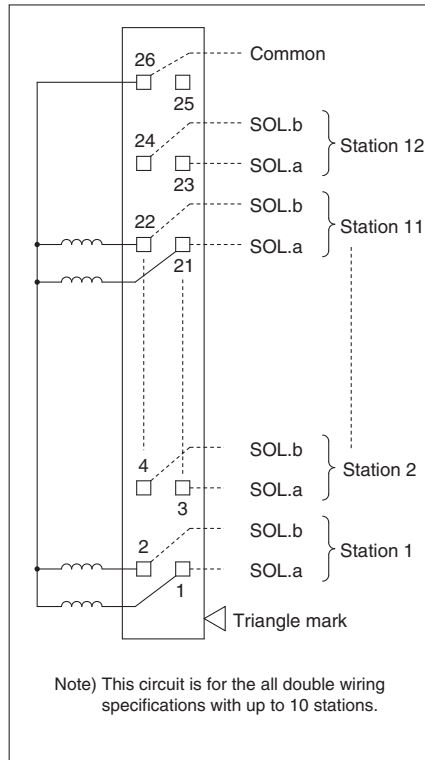

Type 60LPG: Flat ribbon cable (20 pins)

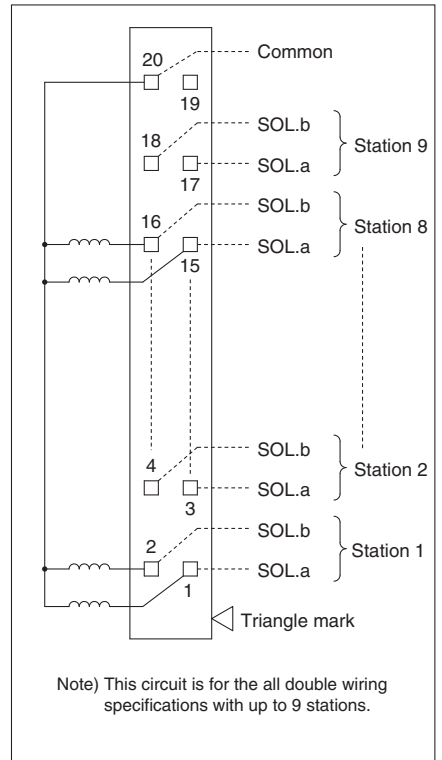

Type 60LPH: Flat ribbon cable (10 pins)

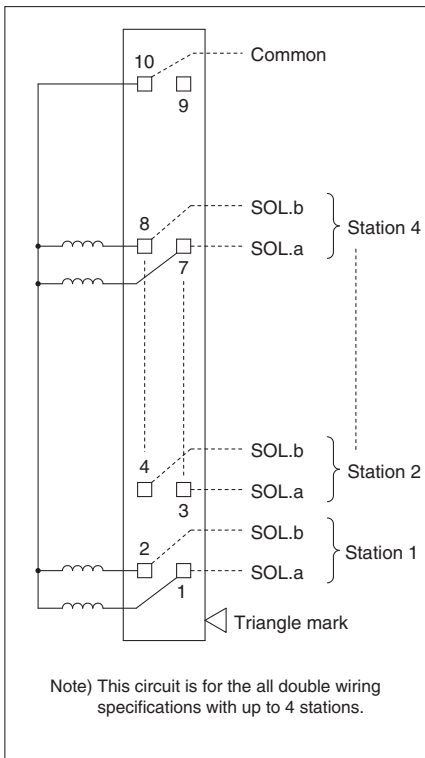

⚠ Caution

When the non-polar U type valves are used, either positive common or negative common wiring of the manifold is possible. However, when the Z type valves are used, select the positive common or negative common according to the wiring specifications.

Series SJ2000/3000

Dimensions: Series SJ2000 for D-sub Connector

SS5J2-60FD₂-[Stations] U(S, R, RS)

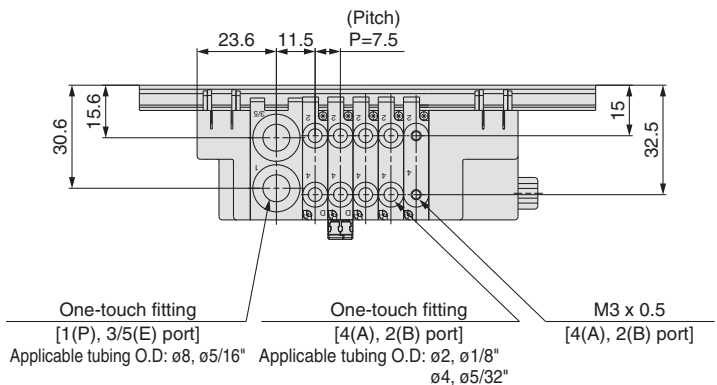
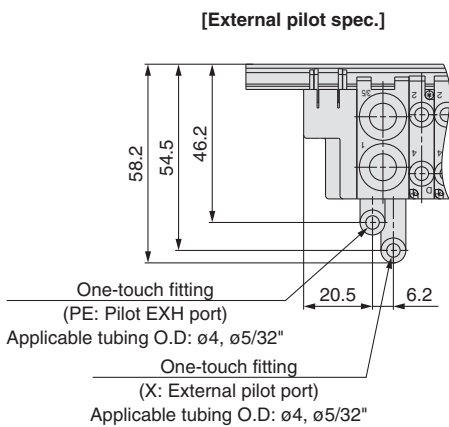
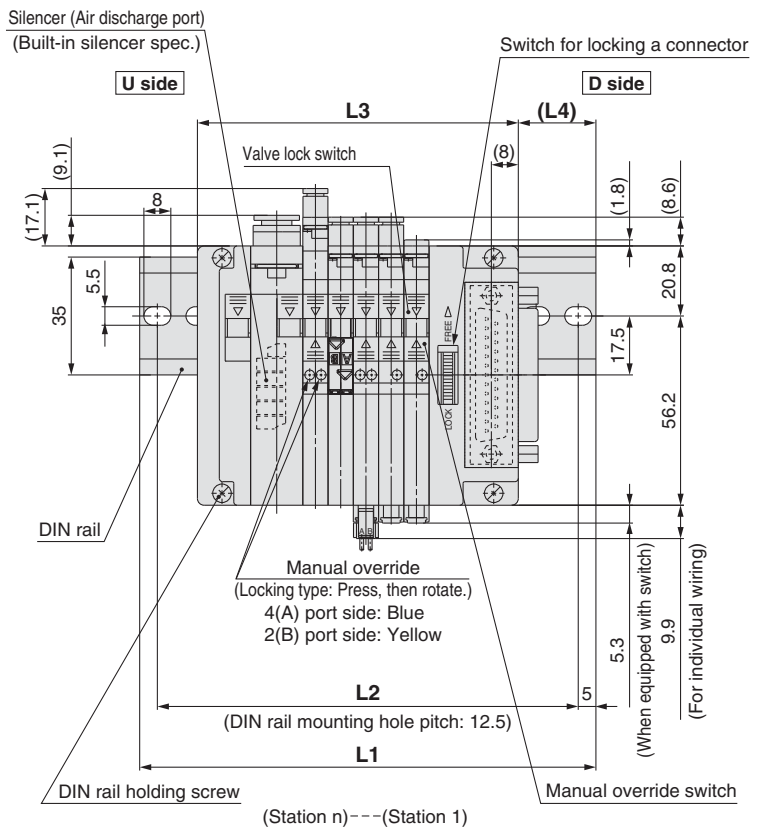
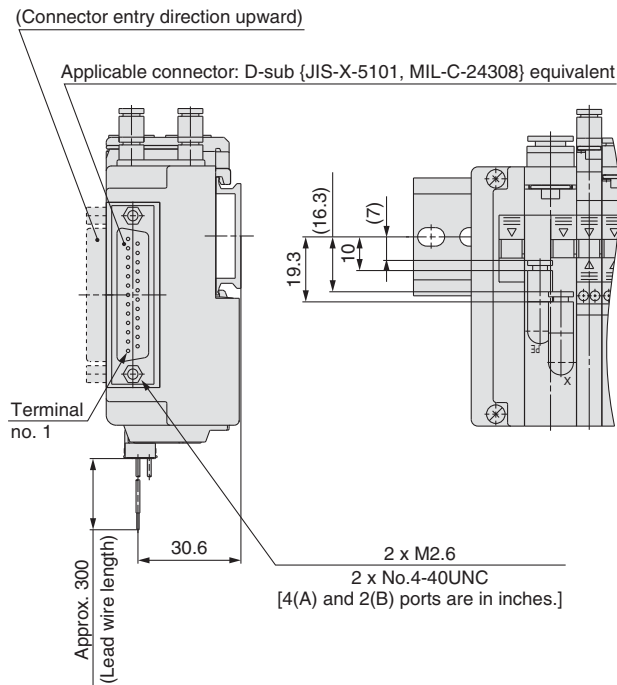
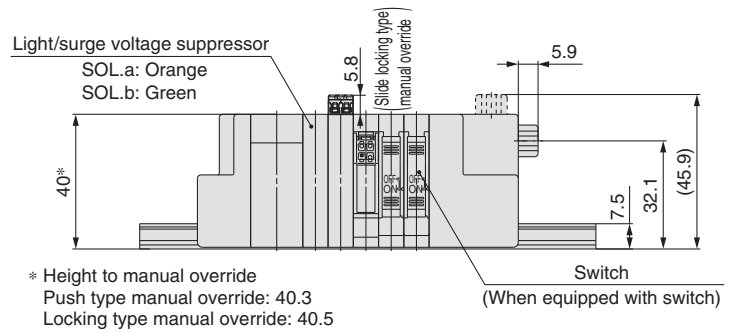
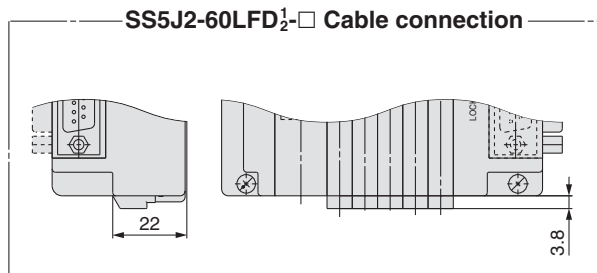

L: Dimensions n: Stations

L	n	1	2	3	4	5	6	7	8	9	10
L1		98	110.5	110.5	123	135.5	135.5	148	148	160.5	173
L2		87.5	100	100	112.5	125	125	137.5	137.5	150	162.5
L3		65.3	72.8	80.3	87.8	95.3	102.8	110.3	117.8	125.3	132.8
L4		19.5	22	18	20.5	23	19.5	22	18	20.5	23

Note) For manifold dimensions including elbow fitting, refer to page 31.

Dimensions: Series SJ2000 for D-sub Connector

SS5J2-60FD₂- [Stations] B(S, R, RS)

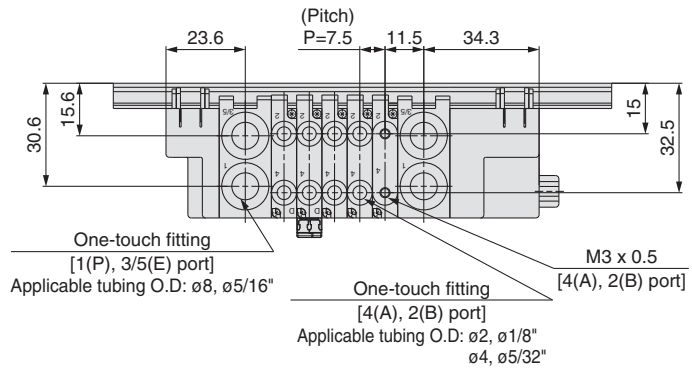
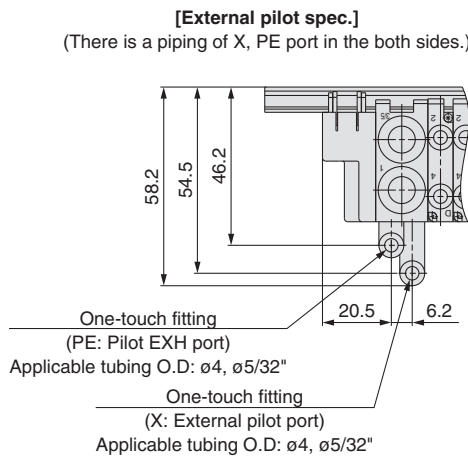
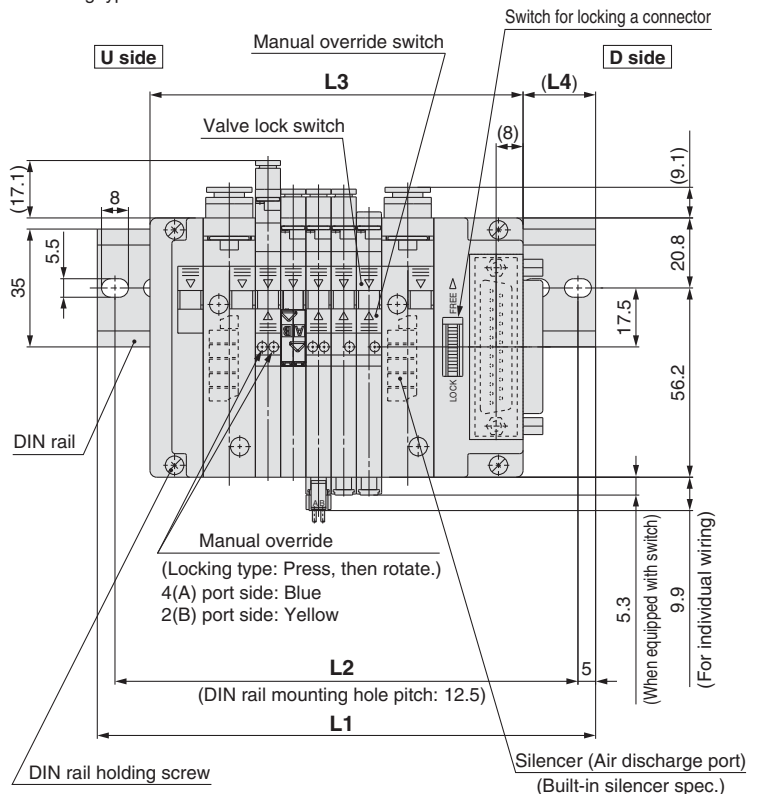
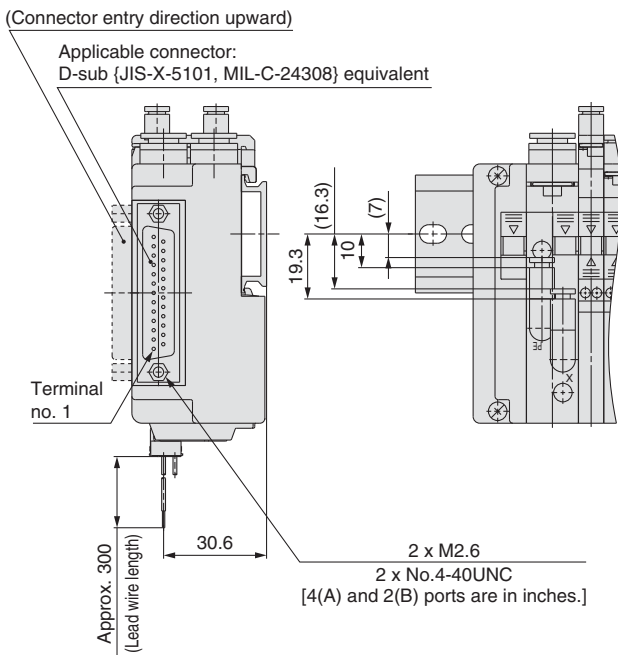
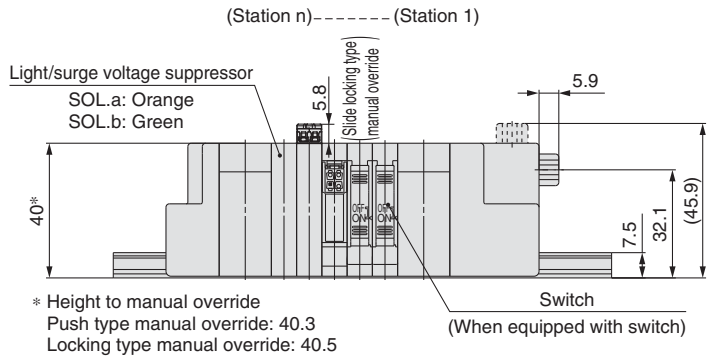
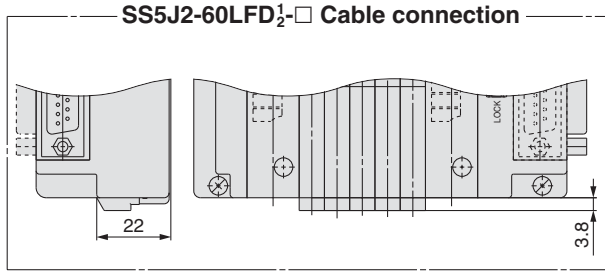

Note) For manifold dimensions including elbow fitting, refer to page 31.

L: Dimensions

L	n	1	2	3	4	5	6	7	8	9	10	11	12	13	14	15	16	17	18	19	20	21	22	23	24
L1	n: Stations	110.5	123	135.5	135.5	148	148	160.5	173	173	185.5	185.5	198	210.5	210.5	223	223	235.5	248	248	260.5	260.5	273	285.5	285.5
L2		100	112.5	125	125	137.5	137.5	150	162.5	162.5	175	175	187.5	200	200	212.5	212.5	225	237.5	237.5	250	250	262.5	275	275
L3		80.8	88.3	95.8	103.3	110.8	118.3	125.8	133.3	140.8	148.3	155.8	163.3	170.8	178.3	185.8	193.3	200.8	208.3	215.8	223.3	230.8	238.3	245.8	253.3
L4		18	20.5	23	19	21.5	18	20.5	23	19	21.5	18	20.5	23	19	21.5	18	20.5	23	19	21.5	18	20.5	23	19

Series SJ2000/3000

Dimensions: Series SJ3000 for D-sub Connector

SS5J3-60FD₂- [Stations] U(S, R, RS)

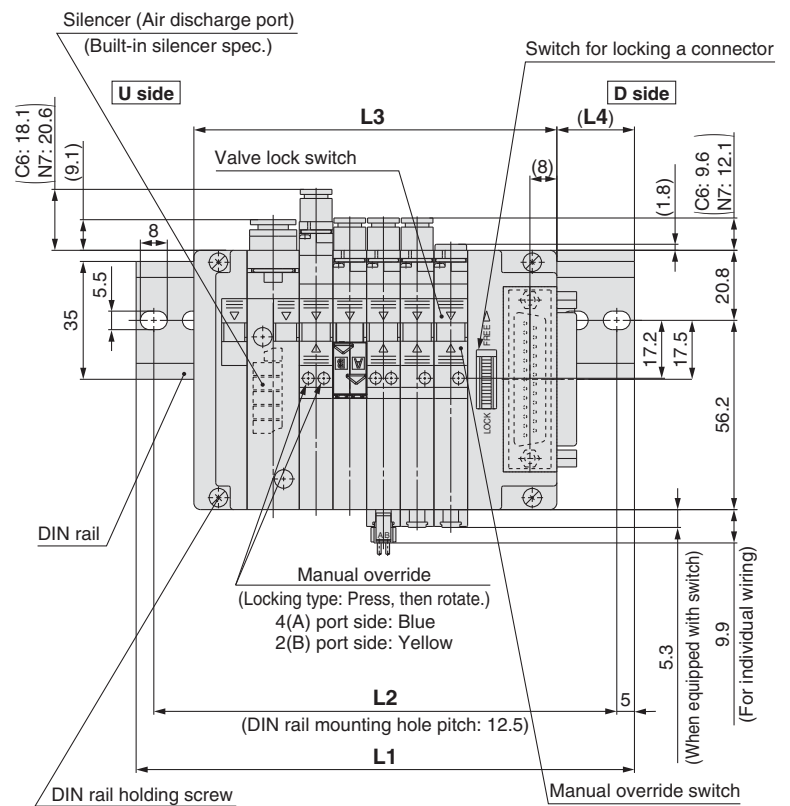
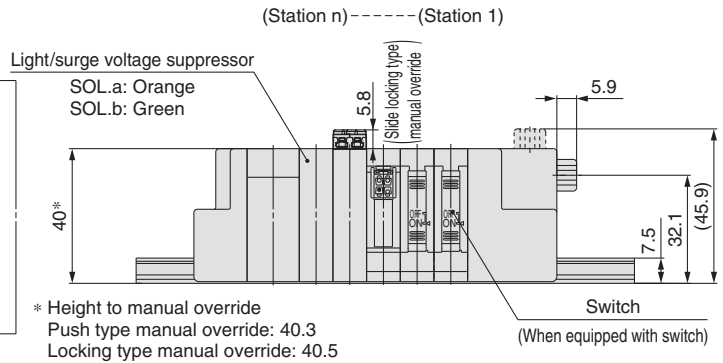
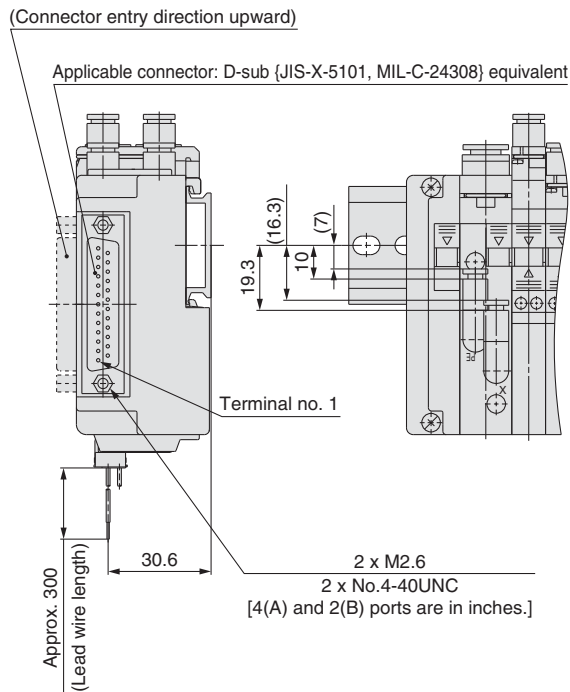
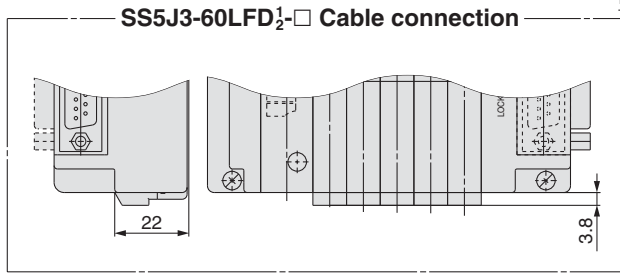

[External pilot spec.]

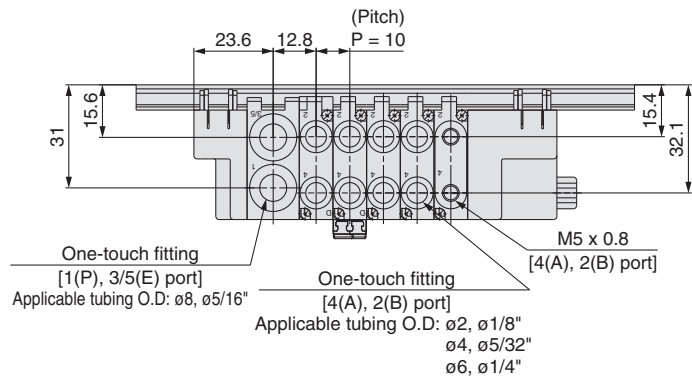
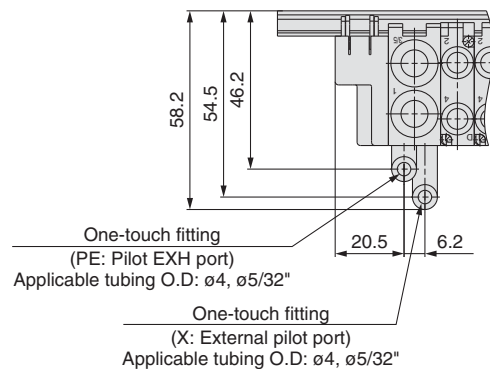

L: Dimensions

L	n: Stations									
	1	2	3	4	5	6	7	8	9	10
L1	98	110.5	123	135.5	148	148	160.5	173	185.5	198
L2	87.5	100	112.5	125	137.5	137.5	150	162.5	175	187.5
L3	67.8	77.8	87.8	97.8	107.8	117.8	127.8	137.8	147.8	157.8
L4	18	19	20.5	21.5	22.5	17.5	18.5	20	21	22

Note) For manifold dimensions including elbow fitting, refer to page 32.

Dimensions: Series SJ3000 for D-sub Connector

SS5J3-60FD₂- [Stations] B(S, R, RS)

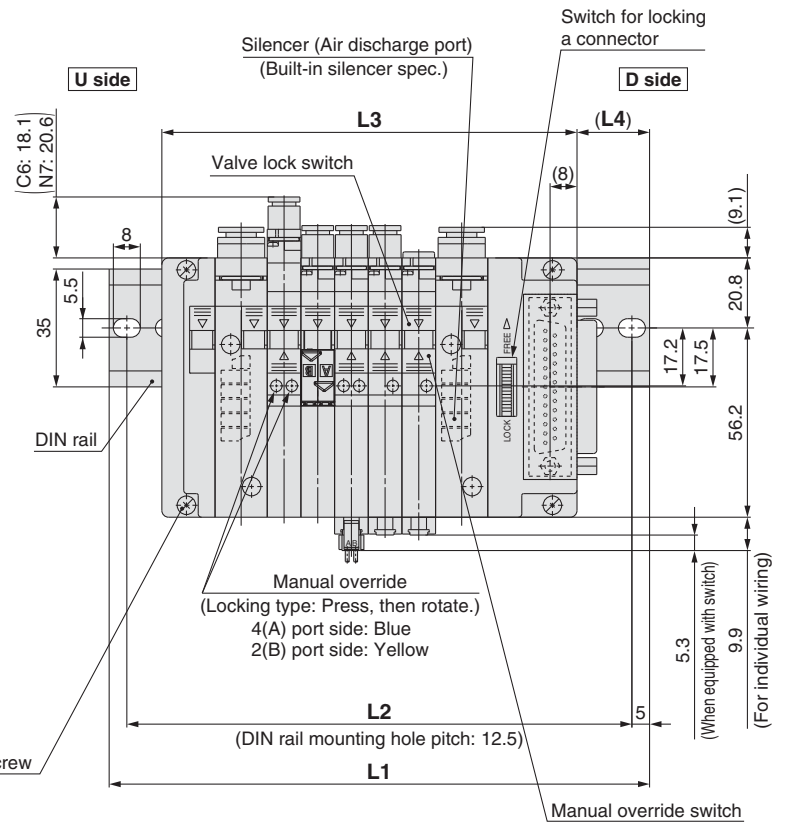
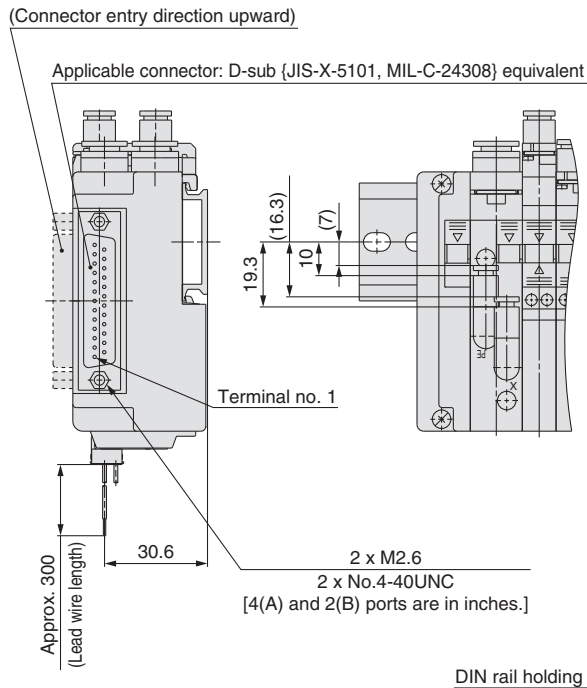
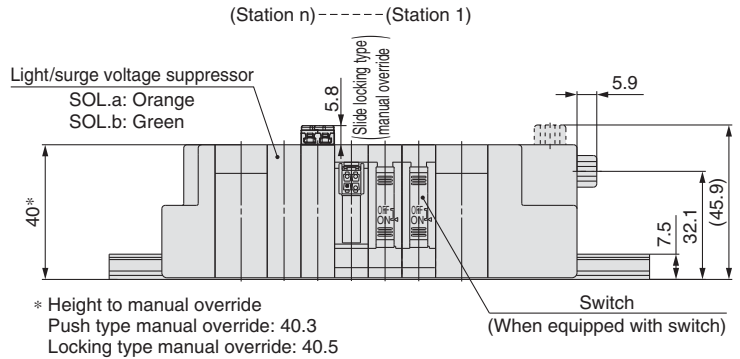
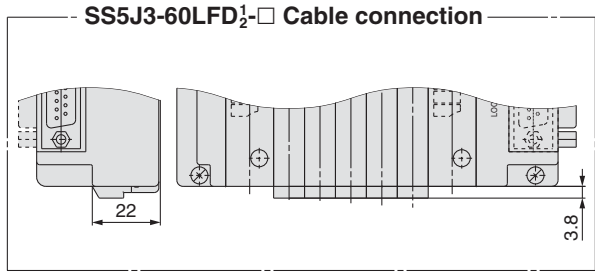

[External pilot spec.]
(There is a piping of X, PE port in the both sides.)

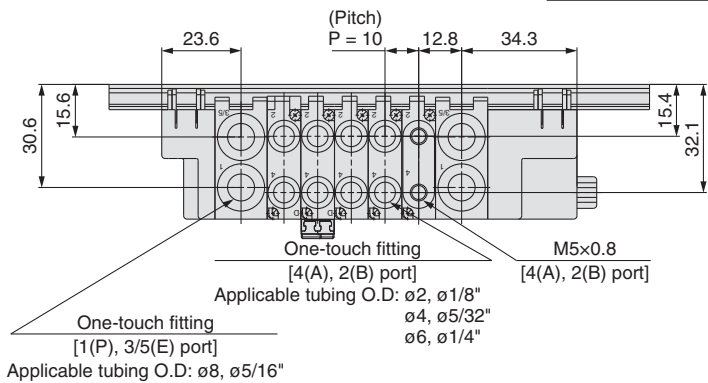
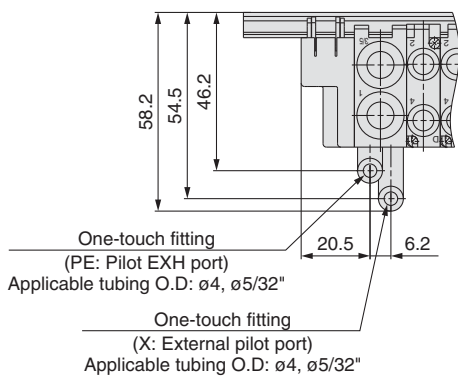

Note) For manifold dimensions including elbow fitting, refer to page 32.

L: Dimensions

L	n: Stations																							
	1	2	3	4	5	6	7	8	9	10	11	12	13	14	15	16	17	18	19	20	21	22	23	24
L1	123	123	135.5	148	160.5	173	185.5	185.5	198	210.5	223	235.5	235.5	248	260.5	273	285.5	298	298	310.5	323	335.5	348	348
L2	112.5	112.5	125	137.5	150	162.5	175	175	187.5	200	212.5	225	225	237.5	250	262.5	275	287.5	287.5	300	312.5	325	337.5	337.5
L3	83.3	93.3	103.3	113.3	123.3	133.3	143.3	153.3	163.3	173.3	183.3	193.3	203.3	213.3	223.3	233.3	243.3	253.3	263.3	273.3	283.3	293.3	303.3	313.3
L4	22.5	17.5	19	20	21	22	23.5	18.5	19.5	20.5	21.5	23	18	19	20	21	22.5	23.5	18.5	19.5	20.5	22	23	18

Series SJ2000/3000

Dimensions: SJ2000/3000 Mixed Manifold

SS5J3-M60FD₂-[Stations] U(S, R, RS)

Applicable connector: D-sub {JIS-X-5101, MIL-C-24308} equivalent

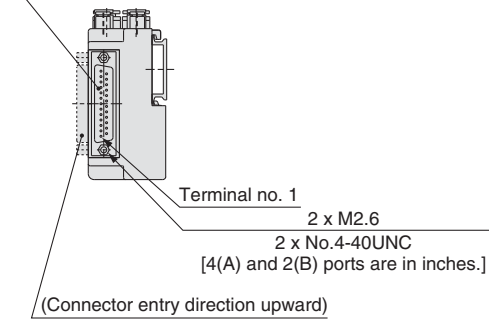

L dimension: Formula, L1 to L4
 $L3 = 7.5 \times n1 + 10 \times n2 + 57.8$
 $M = (L3 + 9.9) / 12.5 + 1$
 Remove all numbers after the decimal.
 $L1 = M \times 12.5 + 23$
 $L2 = L1 - 10.5$
 $L4 = (L1 - L3) / 2 + 1$

n1: Quantity of SJ2000
 n2: Quantity of SJ3000

* The dimensions of L1 to L4 for **SS5J3-M60FD1/2-[Stations] D** are the same as those of **SS5J3-M60FD1/2-[Stations] U**.

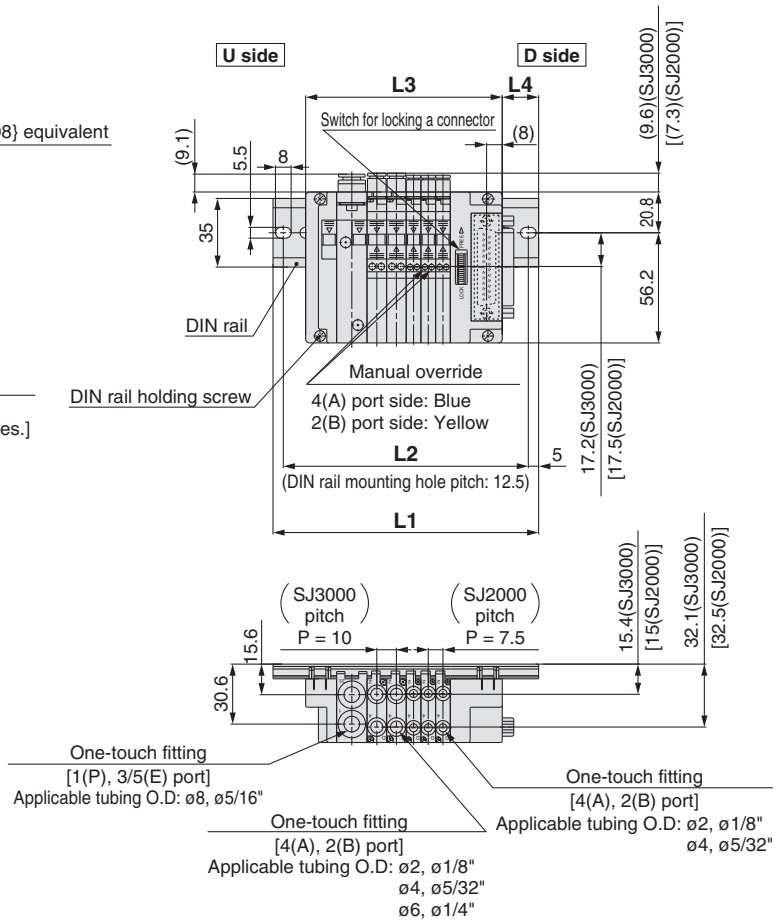

SS5J3-M60FD₂-[Stations] B(S, R, RS)

Applicable connector: D-sub {JIS-X-5101, MIL-C-24308} equivalent

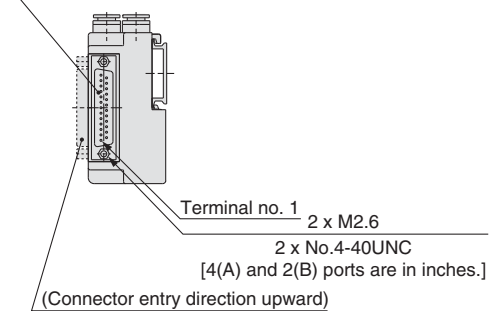

L dimension: Formula, L1 to L4
 $L3 = 7.5 \times n1 + 10 \times n2 + 73.3$
 $M = (L3 + 9.9) / 12.5 + 1$
 Remove all numbers after the decimal.
 $L1 = M \times 12.5 + 23$
 $L2 = L1 - 10.5$
 $L4 = (L1 - L3) / 2 + 1$

n1: Quantity of SJ2000
 n2: Quantity of SJ3000

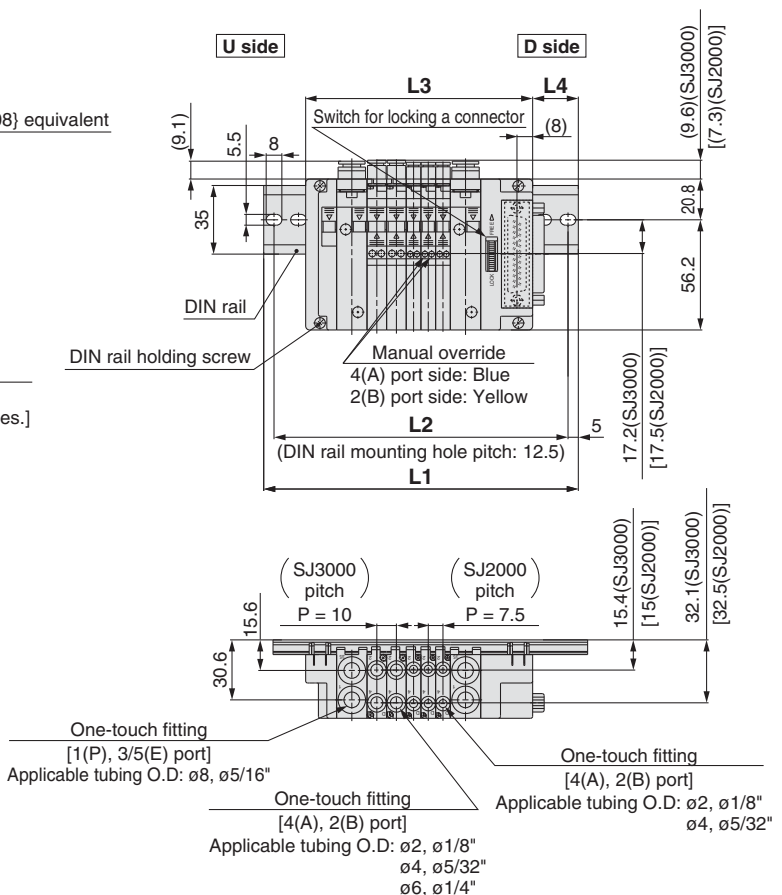

Dimensions: Series SJ2000 for Flat Ribbon Cable/PC Wiring

SS5J2-60_JD₂- Stations U(S, R, RS)

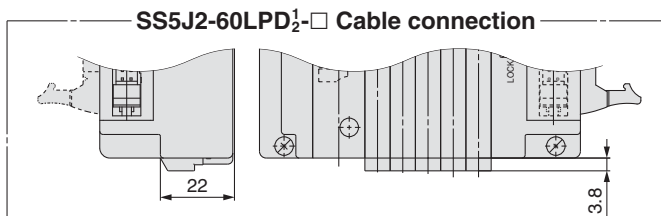
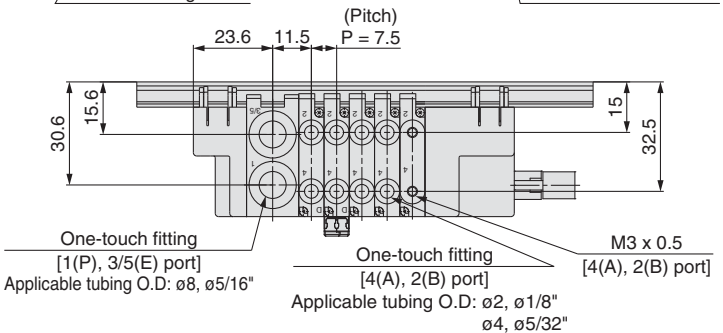
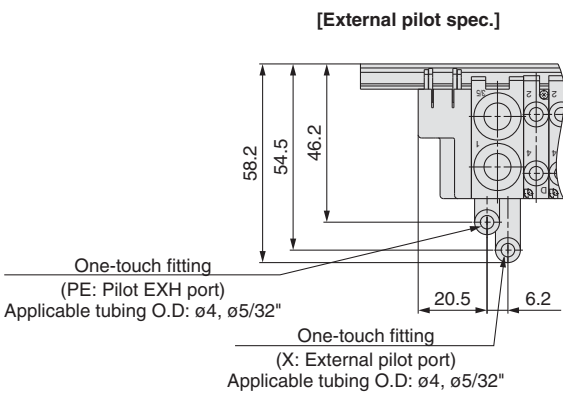
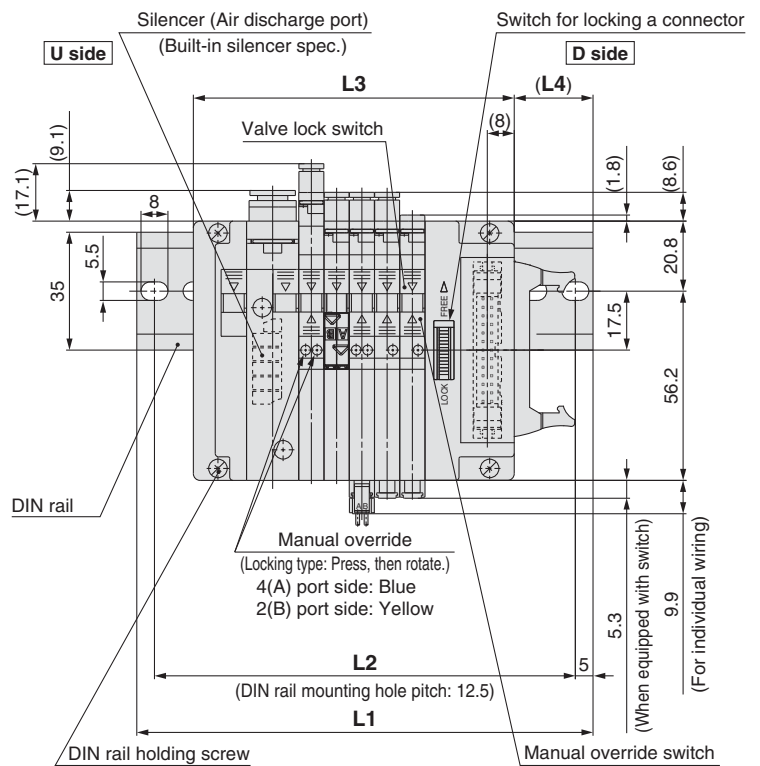
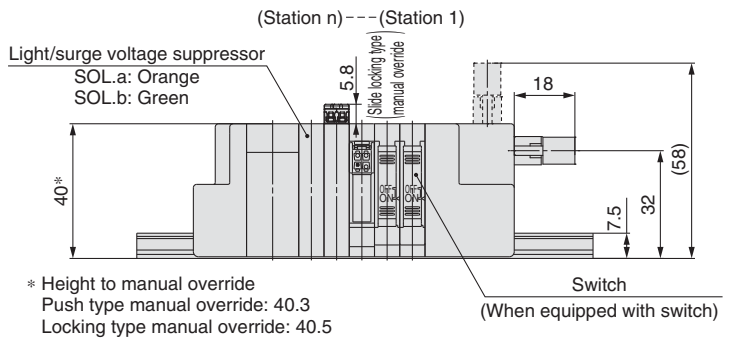
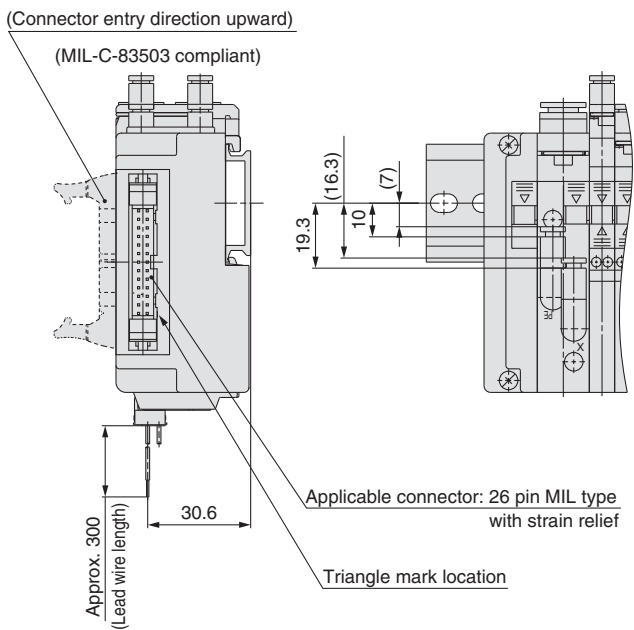
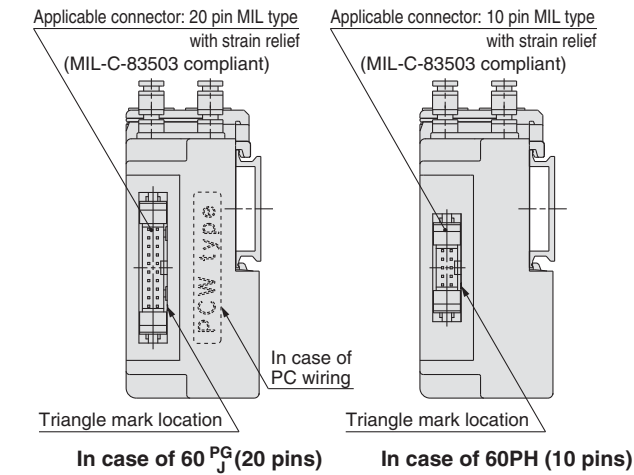

Note 1) Type 60PG, 60PH and 60J differ only in their connectors, and the L1 through L4 dimensions are the same as type 60P.

Note 2) For manifold dimensions including elbow fitting, refer to page 31.

L: Dimensions

L	n: Stations									
	1	2	3	4	5	6	7	8	9	10
L1	98	110.5	110.5	123	135.5	135.5	148	148	160.5	173
L2	87.5	100	100	112.5	125	125	137.5	137.5	150	162.5
L3	65.3	72.8	80.3	87.8	95.3	102.8	110.3	117.8	125.3	132.8
L4	19.5	22	18.5	21	23.5	19.5	22	18.5	21	23.5

Series SJ2000/3000

Dimensions: Series SJ2000 for Flat Ribbon Cable/PC Wiring

SS5J2-60^PD₂¹ - Stations B(S, R, RS)

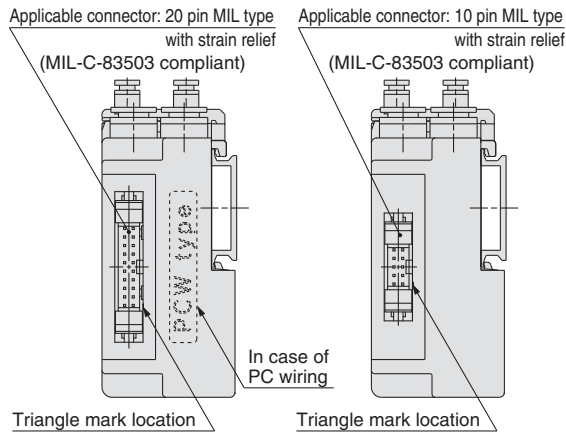

In case of 60^{PG} (20 pins) In case of 60PH (10 pins)

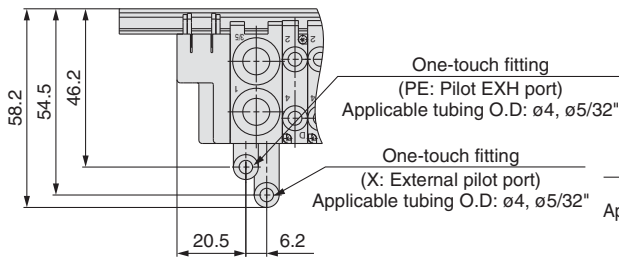
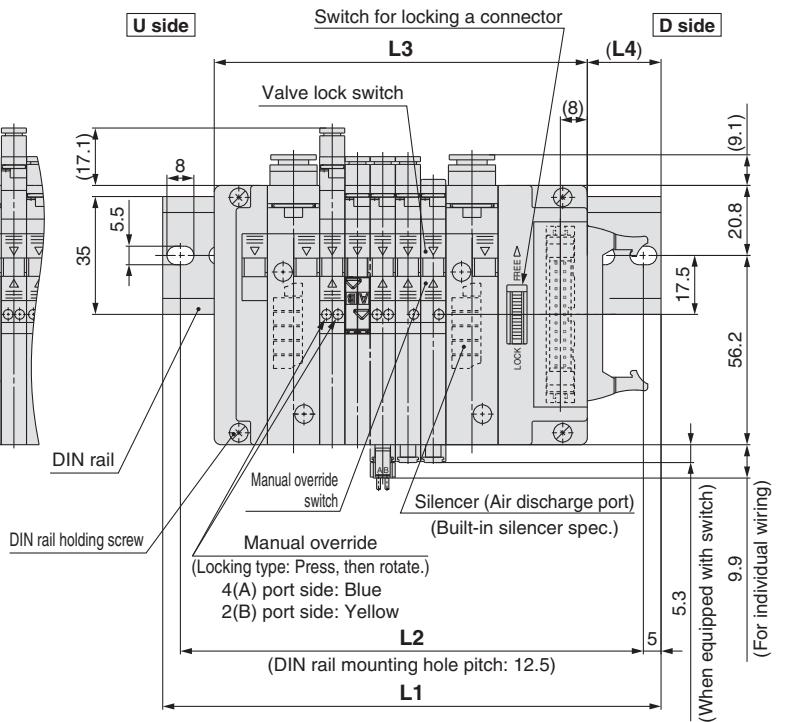
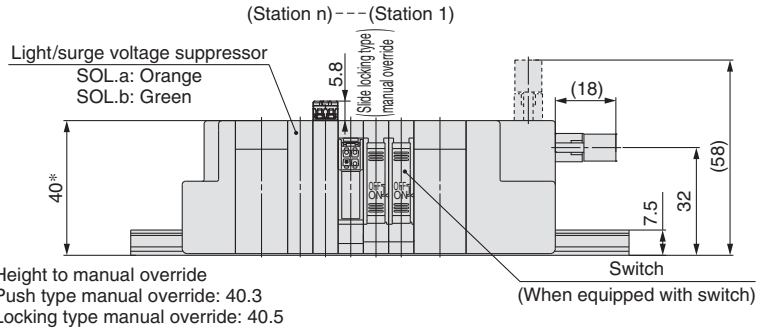
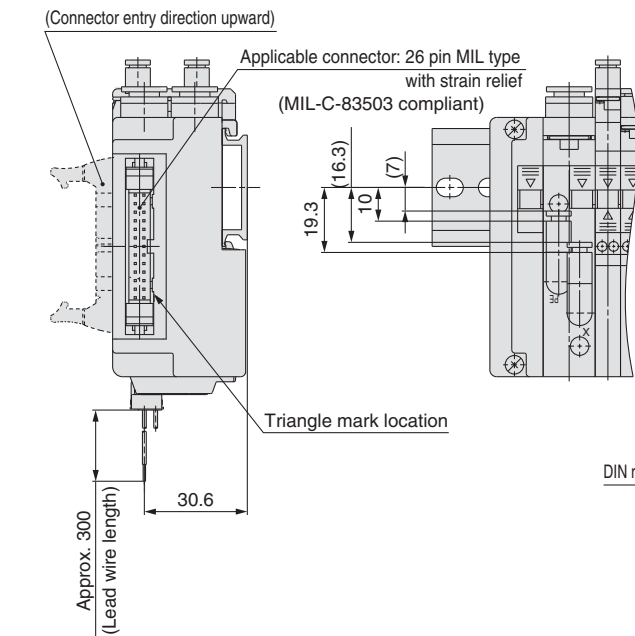

[External pilot spec.]

(There is a piping of X, PE port in the both sides.)

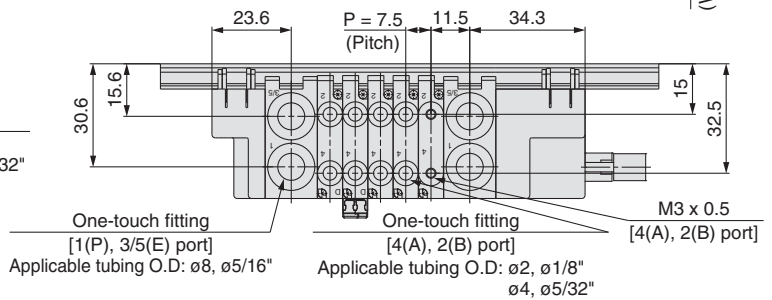

SS5J2-60LPD₂¹ - Cable connection

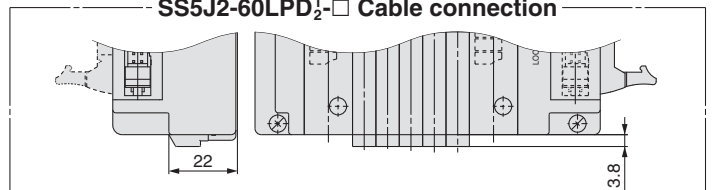

Note 1) Type 60PG, 60PH and 60J differ only in their connectors, and the L1 through L4 dimensions are the same as type 60P.

Note 2) For manifold dimensions including elbow fitting, refer to page 31.

L: Dimensions

L \ n	n: Stations																							
	1	2	3	4	5	6	7	8	9	10	11	12	13	14	15	16	17	18	19	20	21	22	23	24
L1	110.5	123	135.5	135.5	148	148	160.5	173	173	185.5	185.5	198	210.5	210.5	223	223	235.5	248	248	260.5	260.5	273	285.5	285.5
L2	106	112.5	125	125	137.5	137.5	150	162.5	162.5	175	175	187.5	200	200	212.5	212.5	225	237.5	237.5	250	250	262.5	275	275
L3	80.8	88.3	95.8	103.3	110.8	118.3	125.8	133.3	140.8	148.3	155.8	163.3	170.8	178.3	185.8	193.3	200.8	208.3	215.8	223.3	230.8	238.3	245.8	253.3
L4	18	20.5	23	19.5	22	18	20.5	23	19.5	22	18	20.5	23	19.5	22	18	20.5	23	19.5	22	18	20.5	23	19.5

Dimensions: Series SJ3000 for Flat Ribbon Cable/PC Wiring

SS5J3-60^PD₂- Stations U(S, R, RS)

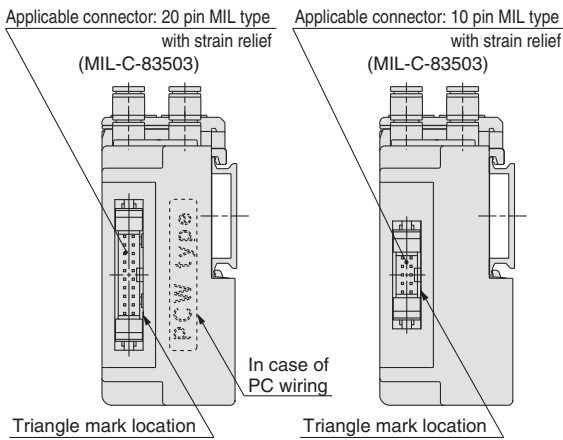

In case of 60^PG(20 pins)

In case of 60PH (10 pins)

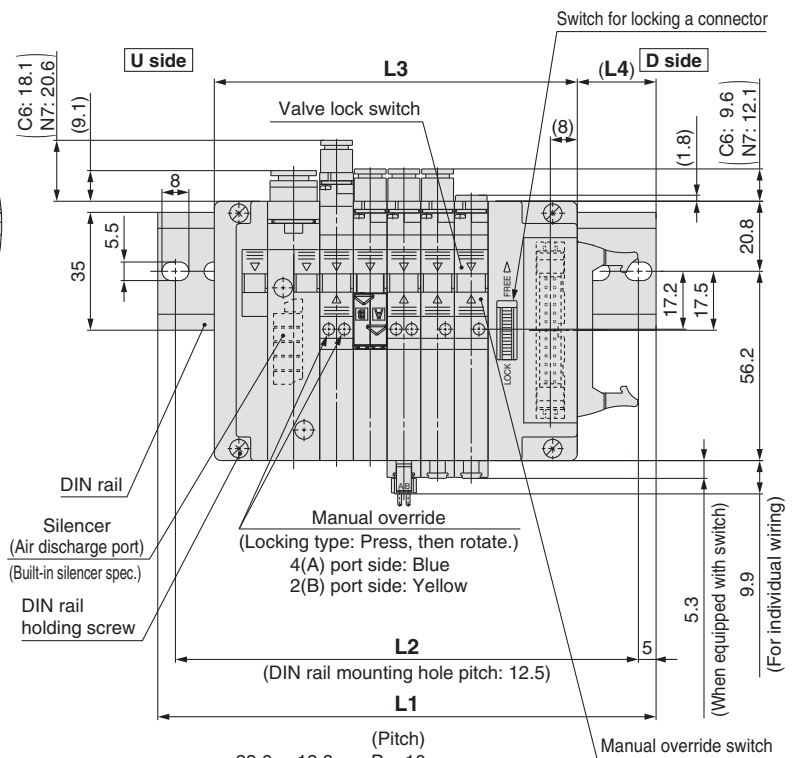
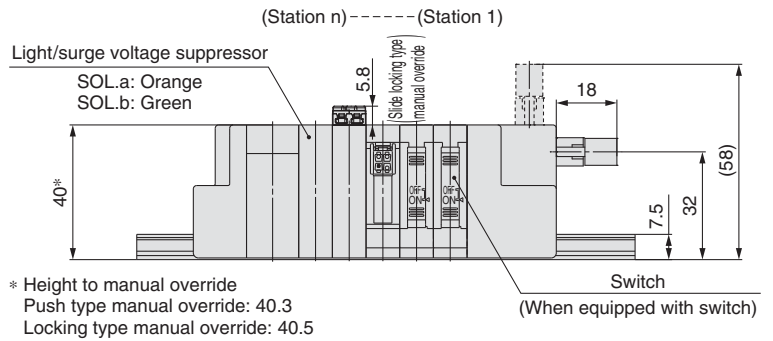
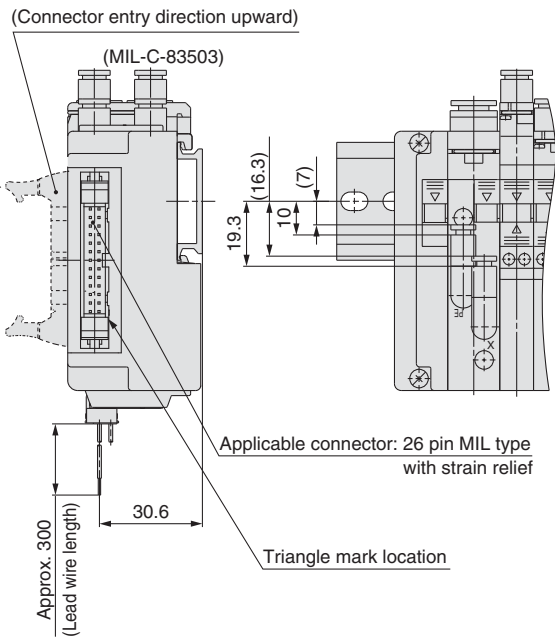

[External pilot spec.]

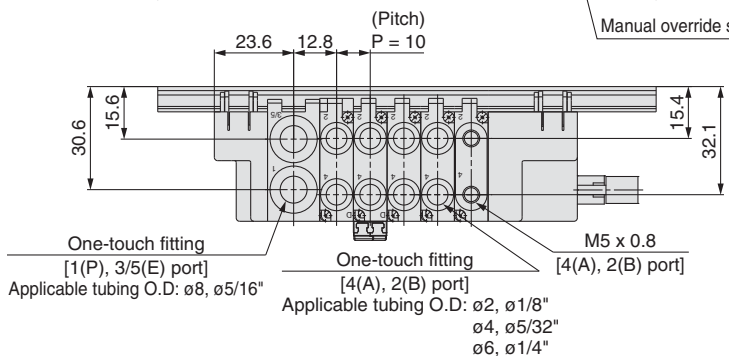
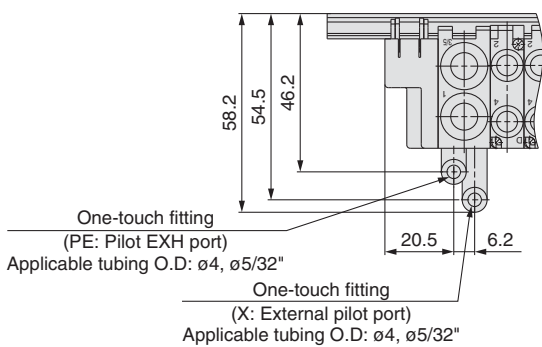

SS5J3-60LPD₂- Cable connection

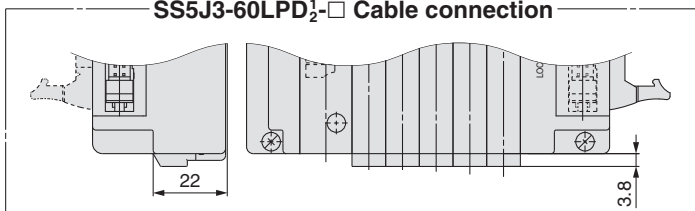

Note 1) Type 60PG, 60PH and 60J differ only in their connectors, and the L1 through L4 dimensions are the same as type 60P.
Note 2) For manifold dimensions including elbow fitting, refer to page 32.

L: Dimensions

L	n: Stations									
	1	2	3	4	5	6	7	8	9	10
L1	98	110.5	123	135.5	148	160.5	160.5	173	185.5	198
L2	87.5	100	112.5	125	137.5	150	150	162.5	175	187.5
L3	67.8	77.8	87.8	97.8	107.8	117.8	127.8	137.8	147.8	157.8
L4	18.5	19.5	20.5	22	23	24	19	20	21.5	22.5

SJ
2000
3000

Common
Specifications

Construction

Plug-in

Connector Type/
Cable Type

Non plug-in

Individual
Wiring

Manifold
Options

Made to
Order

SJ3A6

Common Specifications/
Construction

Plug-in

Connector Type/
Cable Type

Non plug-in

Individual
Wiring

Series SJ2000/3000

Dimensions: Series SJ3000 for Flat Ribbon Cable/PC Wiring

SS5J3-60^PD₂¹- Stations B(S, R, RS)

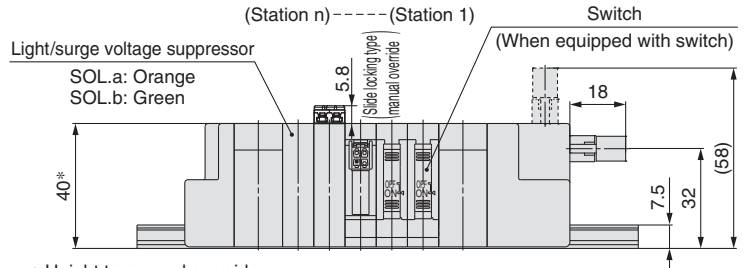
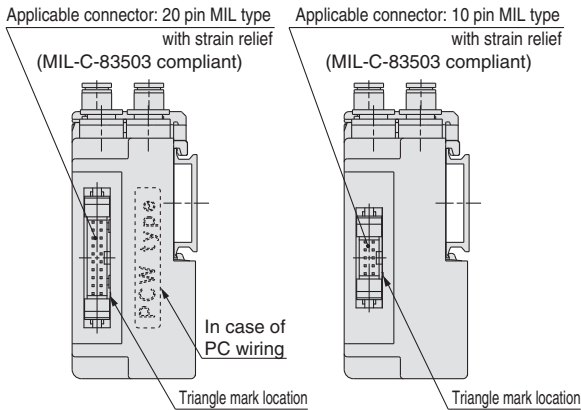

* Height to manual override
 Push type manual override: 40.3
 Locking type manual override: 40.5

In case of 60^{PG} (20 pins) In case of 60PH (10 pins)

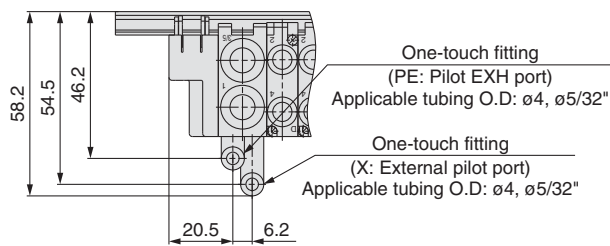
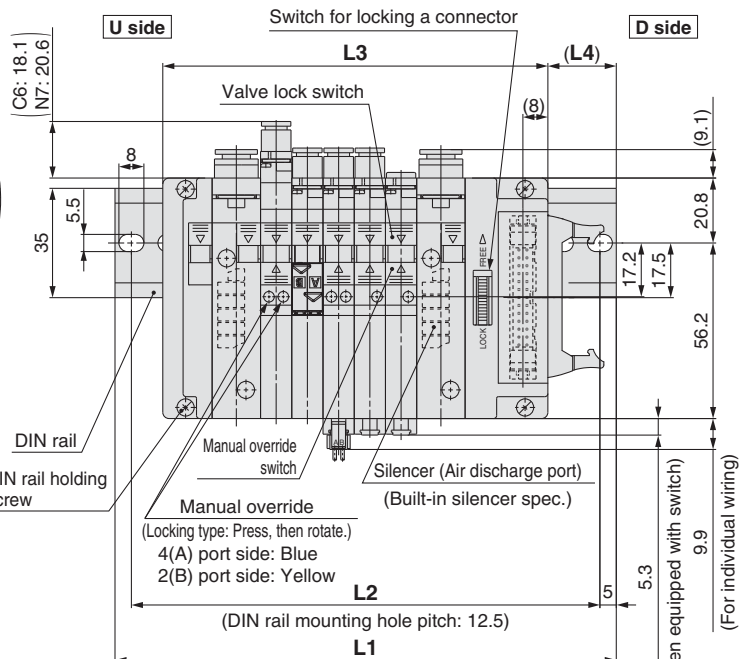
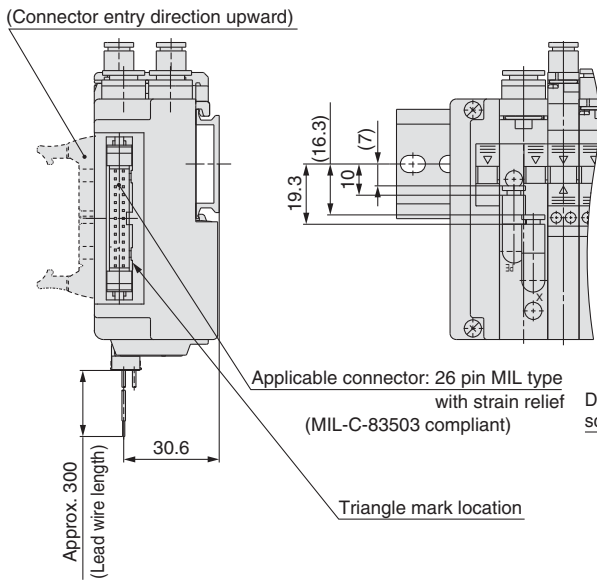

[External pilot spec.]

(There is a piping of X, PE port in the both sides.)

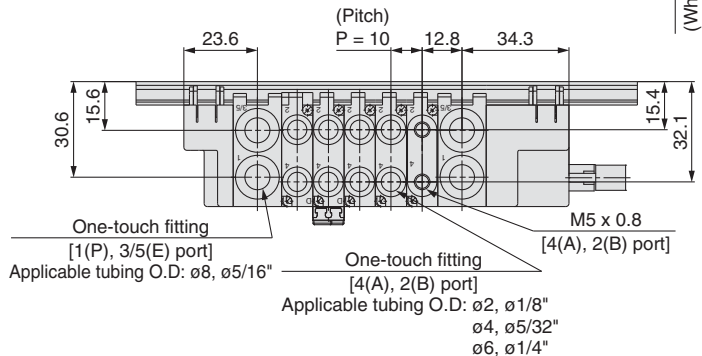

SS5J3-60LPD₂¹- Cable connection

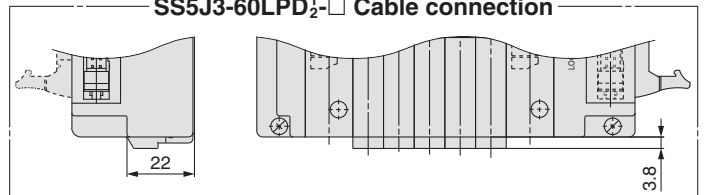

Note 1) Type 60PG, 60PH and 60J differ only in their connectors, and the L1 through L4 dimensions are the same as type 60P.

Note 2) For manifold dimensions including elbow fitting, refer to page 32.

L: Dimensions

L \ n	n: Stations																							
	1	2	3	4	5	6	7	8	9	10	11	12	13	14	15	16	17	18	19	20	21	22	23	24
L1	123	135.5	135.5	148	160.5	173	185.5	185.5	198	210.5	223	235.5	248	248	260.5	273	285.5	298	298	310.5	323	335.5	348	348
L2	112.5	125	125	137.5	150	162.5	175	175	187.5	200	212.5	225	237.5	237.5	250	262.5	275	287.5	287.5	300	312.5	325	337.5	337.5
L3	83.3	93.3	103.3	113.3	123.3	133.3	143.3	153.3	163.3	173.3	183.3	193.3	203.3	213.3	223.3	233.3	243.3	253.3	263.3	273.3	283.3	293.3	303.3	313.3
L4	23	24	19	20.5	21.5	22.5	23.5	18.5	20	21	22	23	24.5	19.5	20.5	21.5	22.5	24	19	20	21	22	23.5	18.5

Dimensions: SJ2000/3000 Mixed Manifold

SS5J3-M60PD₂-[Stations] U(S, R, RS)

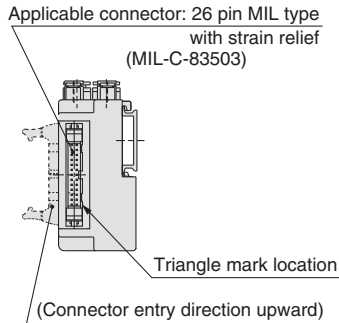

L dimension: Formula, L1 to L4
 $L3 = 7.5 \times n1 + 10 \times n2 + 57.8$
 $M = (L3 + 10.6) / 12.5 + 1$
 Remove all numbers after the decimal.
 $L1 = M \times 12.5 + 23$
 $L2 = L1 - 10.5$
 $L4 = (L1 - L3) / 2 + 1.3$

n1: Quantity of SJ2000
 n2: Quantity of SJ3000

* The dimensions of L1 to L4 for **SS5J3-M60PD1/2-[Stations] D** are the same as those of **SS5J3-M60PD1/2-[Stations] U**.

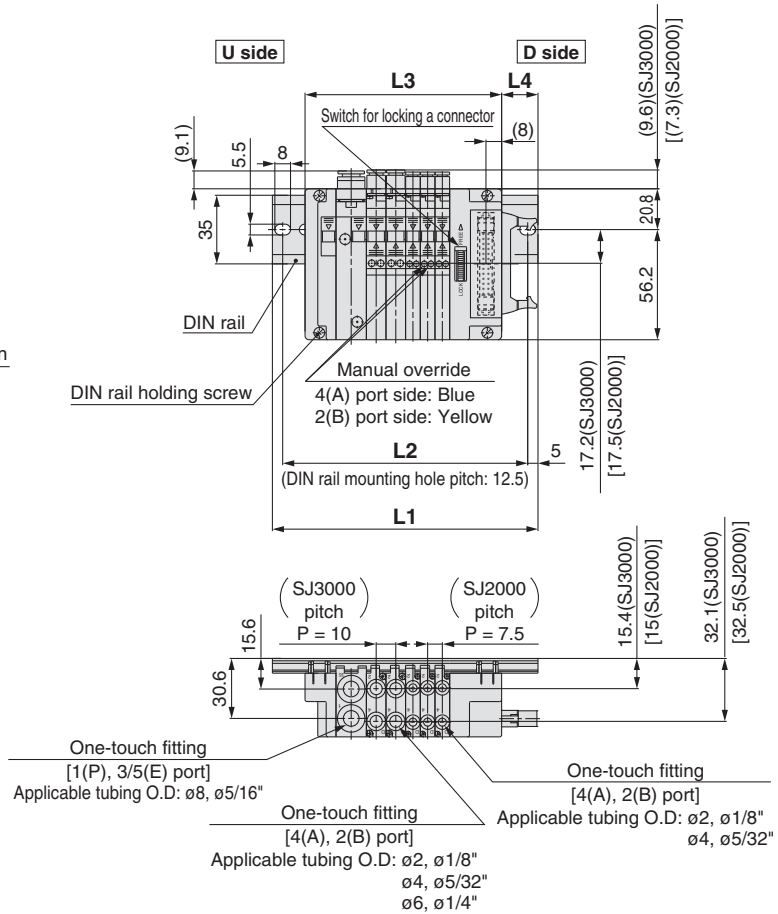

SS5J3-M60PD₂-[Stations] B(S, R, RS)

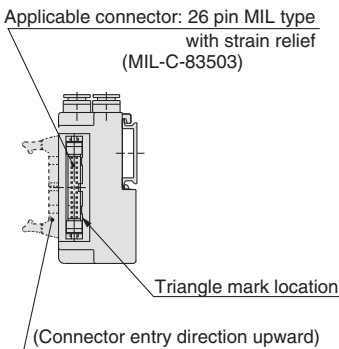

L dimension: Formula, L1 to L4
 $L3 = 7.5 \times n1 + 10 \times n2 + 73.3$
 $M = (L3 + 10.6) / 12.5 + 1$
 Remove all numbers after the decimal.
 $L1 = M \times 12.5 + 23$
 $L2 = L1 - 10.5$
 $L4 = (L1 - L3) / 2 + 1.3$

n1: Quantity of SJ2000
 n2: Quantity of SJ3000

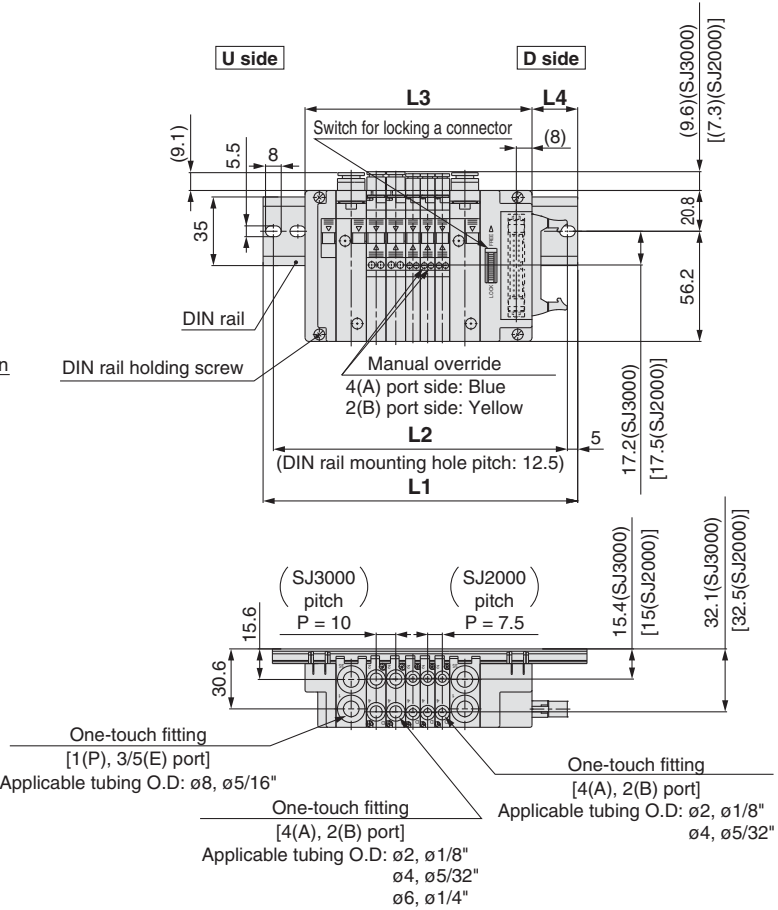

SJ
2000
3000

Common Specifications

Construction

Connector Type/
Cable Type

Plug-in

Non plug-in

Individual Wiring

Manifold Options

Made to Order

SJ3A6

Common Specifications/
Construction

Connector Type/
Cable Type

Plug-in

Non plug-in

Individual Wiring

Series SJ2000/3000

Dimensions: Series SJ2000 with Elbow Fittings

SS5J2-60FD₂-[Stations]U_B

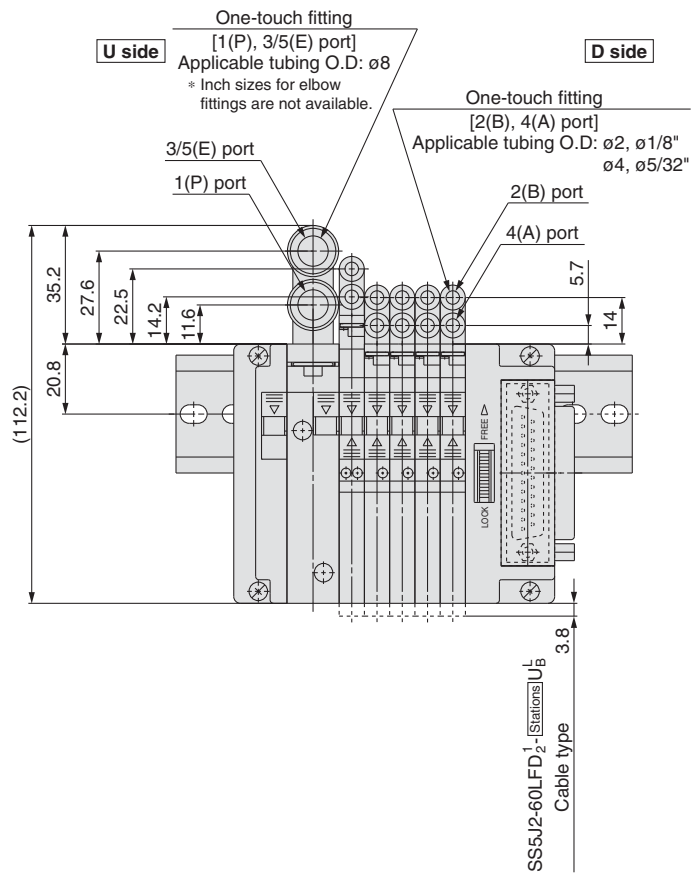
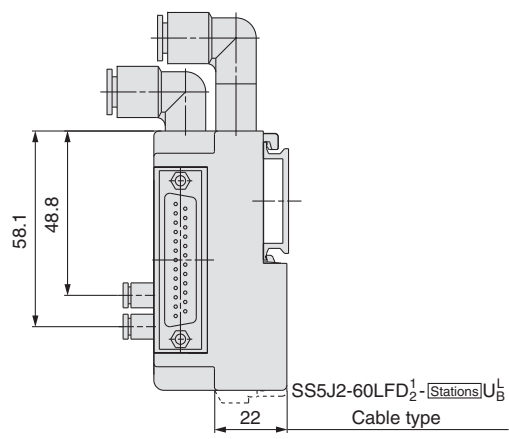
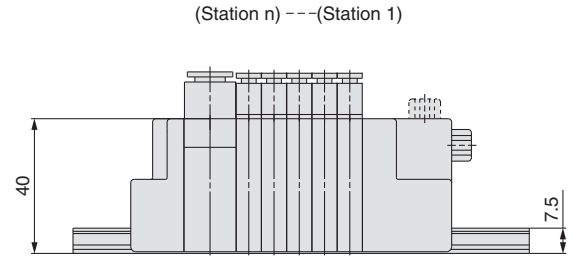
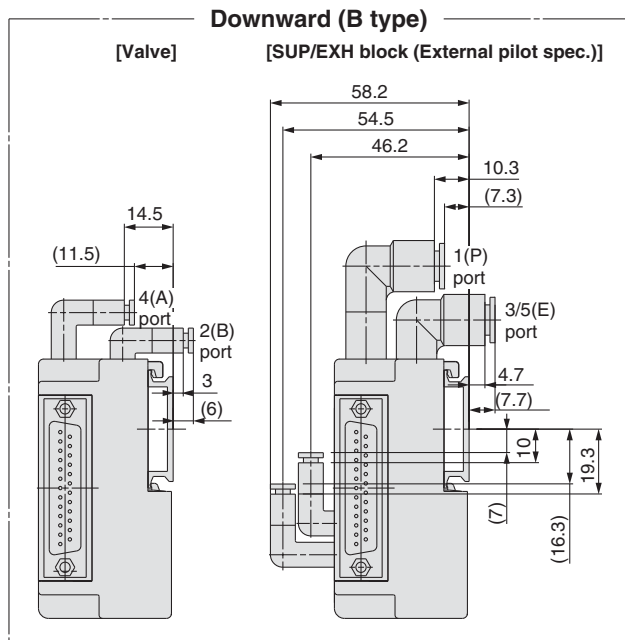

[SUP/EXH block (External pilot spec.)]

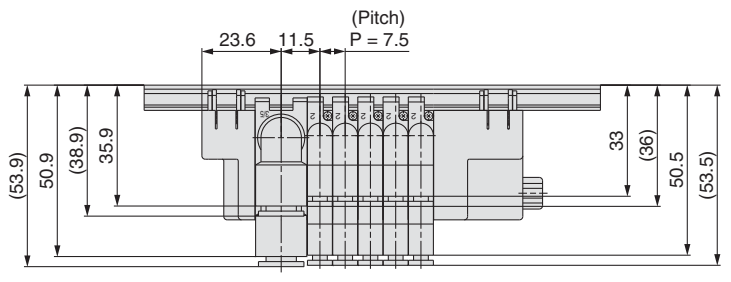
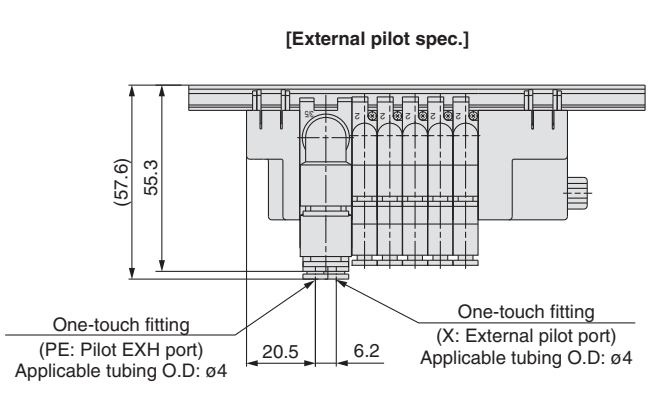

Dimensions: Series SJ3000 with Elbow Fittings

SS5J3-60FD₂-[Stations]U_B

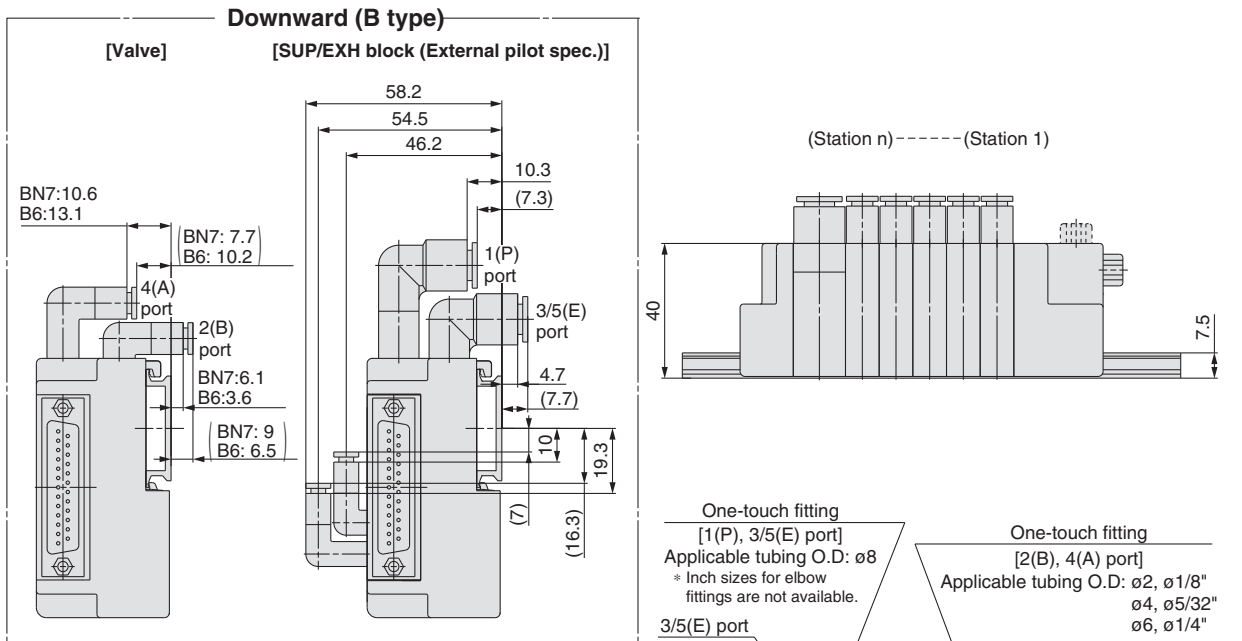

One-touch fitting [1(P), 3/5(E) port]
Applicable tubing O.D: $\phi 8$
* Inch sizes for elbow fittings are not available.

One-touch fitting [2(B), 4(A) port]
Applicable tubing O.D: $\phi 2, \phi 1/8''$
 $\phi 4, \phi 5/32''$
 $\phi 6, \phi 1/4''$

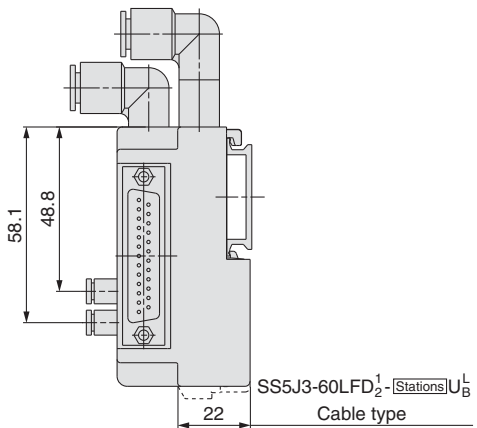

[SUP/EXH block (External pilot spec.)]

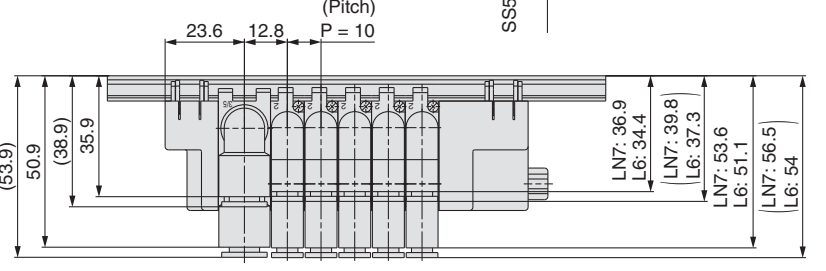
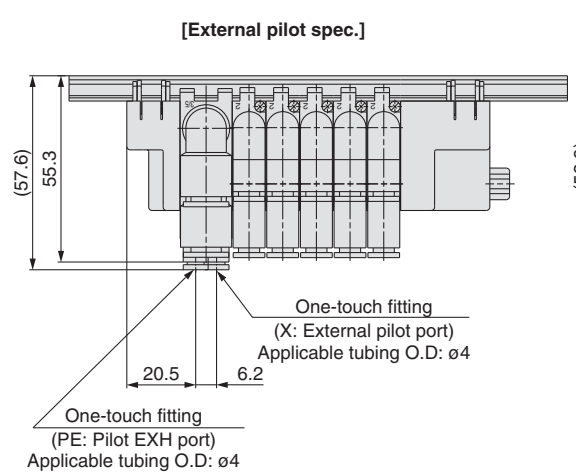
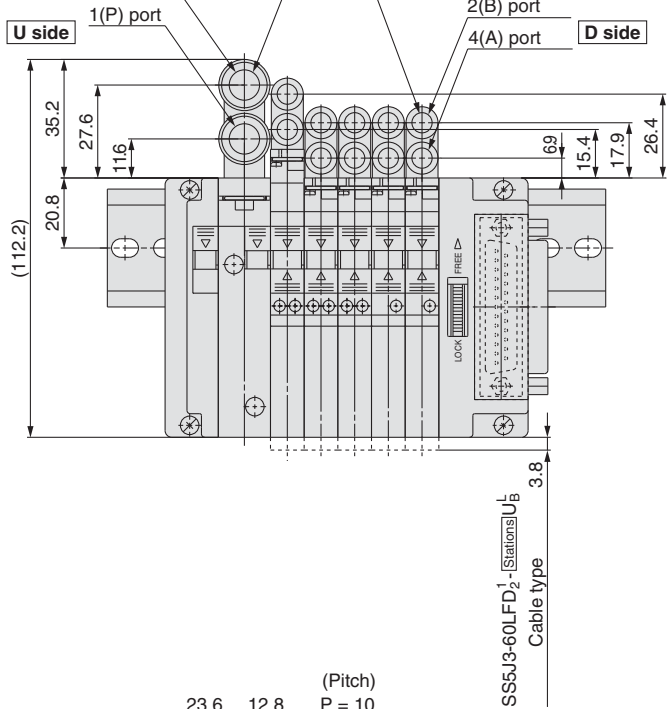

SJ 2000 3000	Common Specifications
Construction	Plug-in
Connector Type/ Cable Type	Plug-in
Individual Wiring	Non plug-in
Manifold Options	
Made to Order	
SJ3A6	
Common Specifications/ Construction	Plug-in
Connector Type/ Cable Type	Plug-in
Individual Wiring	Non plug-in

Plug-in Connector Type PC Wiring System with Power Supply Terminal



Series SJ2000/3000

An order cannot be placed with only the manifold part no. Be sure to order solenoid valves for mounting at the same time while referring to the ordering example.

How to Order

● Connector type manifold

SS5J **3** - **60GD** - **05U** □ □ □

Series

2	SJ2000
3	SJ3000 (SJ2000/3000 mixed)

Mixed mounting type

—	Standard ^{Note 1)}
M	Mixed mounting ^{Note 2)}

Note 1) There is no need to enter anything when you operate either the SJ2000 or SJ3000 series alone.

Note 2) Enter "M" when the SJ2000 or SJ3000 series will be mounted on the same manifold base together.

Connector type

Flat ribbon cable (20 pins)

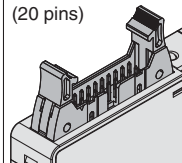

Connector mounting position

Symbol	Mounting position
D	D side

● DIN rail length specified

—	Standard length	
2	2 stations	Specify a longer rail than the standard length.
⋮	⋮	
16	16 stations	

* Specify the valve stations not exceeding the maximum stations.

● SUP/EXH block fitting spec.

—	Straight fitting	
	With external pilot spec. X, PE port	
L	Elbow fitting (Upward)	
	With external pilot spec. X, PE port	
B	Elbow fitting (Downward)	
	With external pilot spec. X, PE port	

* There is no need to enter anything when the SUP/EXH block mounting position "M" is selected.

● Pilot spec.

—	Internal pilot
S	Internal pilot/Built-in silencer
R	External pilot
RS	External pilot/Built-in silencer

* There is no need to enter anything when the SUP/EXH block mounting position "M" is selected.

* For built-in silencers, the 3/5(E) ports are plugged.

● SUP/EXH block mounting position

U	U side (1 to 10 stations)
D	D side (1 to 10 stations)
B	Both sides (1 to 16 stations)
M*	Special specifications

* Specify the required specifications (including port sizes other than ø8) by means of the manifold specification sheet.

● Valve stations

Symbol	Stations	Note
01	1 station	Up to 16 solenoids possible.
⋮	⋮	
16	16 stations	

* The number of the blanking block assembly is also included. Since single and double wiring are available with the blanking block assembly, select a model compatible with the valve wiring spec. planned for the future. (Refer to page 70.)

How to Order Manifold Assembly

Ordering example (SJ3000)

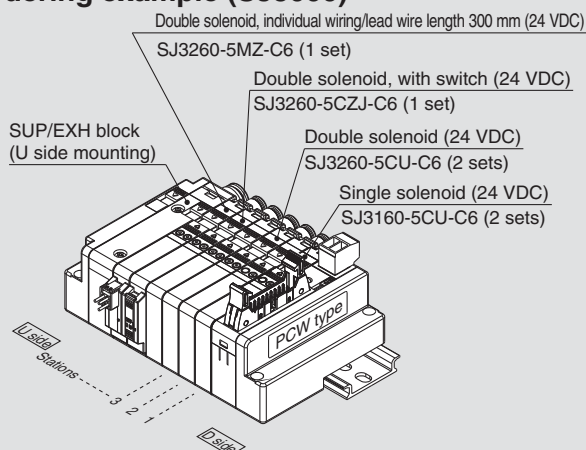

SS5J3-60GD-06U... 1 set (Manifold part no.)
 * SJ3160-5CU-C6... 2 sets (Single solenoid part no.)
 * SJ3260-5CU-C6... 2 sets (Double solenoid part no.)
 * SJ3260-5CZJ-C6... 1 set (Double solenoid, with switch part no.)
 * SJ3260-5MZ-C6... 1 set (Double solenoid, individual wiring/lead wire length 300 mm part no.)

→ The asterisk denotes the symbol for assembly. Prefix to the part no. of the solenoid valve, etc.

- The valve arrangement is numbered as the 1st station from D side.
- Indicate the valves to be attached below the manifold part number, in order starting from station 1 as shown in the drawing. In the case of complex arrangement, specify them in the manifold specification sheet.

Note) When ordering a manifold, specify the part nos. of valves to be mounted together. (An order cannot be placed with only the manifold part no.)



For the wiring to power supply terminal, refer to page 102.

How to Order Solenoid Valves

Standard

SJ 3 1 60 [] [] [] - 5 C U [] - C6 - []

With switch

SJ 3 1 60 [] [] [] - 5 C Z J [] - C6 - []

Individual wiring
 [For plug-in mixed mounting]^{Note 1)}

SJ 3 1 60 [] [] [] - 5 M Z [] - C6

Note 1) Refer to pages 61 and 62 for the dedicated non plug-in individual wiring.

Series

2	SJ2000
3	SJ3000

Back pressure check valve

—	None
K	Built-in

* Back pressure check valve is not applicable for 3 position valve.

Single solenoid wiring spec.

—	Single wiring
D	Double wiring

* There is no need to enter anything for 2 position double, 3 position and 4 position solenoid valves. Select this when the unused numbers to wiring are set. Refer to page 5 for details.

Type of actuation

1	2 position single solenoid
2	2 position double solenoid
3	3 position closed centre
4	3 position exhaust centre
5	3 position pressure centre
A	Dual 3 port valve: N.C./N.C.
B	Dual 3 port valve: N.O./N.O.
C	Dual 3 port valve: N.C./N.O.

* Refer to page 6 through to 13 for the Symbol.

Pilot spec.

—	Internal pilot
R	External pilot

* External pilot spec. is not applicable for 4 position dual 3 port valves.

Rated voltage

5	24 VDC
---	--------

Coil spec.

—	Standard
T	With power saving circuit (Continuous duty type)

* Be sure to select "with power saving circuit" when the solenoid valve will be energised continuously for long period.

Light/surge voltage suppressor

U	With light/surge voltage suppressor (Non-polar type)
Z	With light/surge voltage suppressor (Polar type)

* When the types with power saving circuit, with switches, and/or individual wiring are used, the non-polar type cannot be selected.
 * "Z" is positive common spec.

A, B port size

Straight (Metric size)
C2: ø2 One-touch fitting
C4: ø4 One-touch fitting
C6: ø6 One-touch fitting (SJ3000 only)

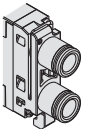

(Inch size)
N1: ø1/8" One-touch fitting
N3: ø5/32" One-touch fitting
N7: ø1/4" One-touch fitting (SJ3000 only)

M3: M3 x 0.5 (SJ2000 only)
M5: M5 x 0.8 (SJ3000 only)



Connector entry

C: Dedicated for centralised wiring

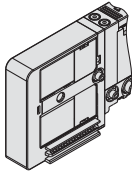

M: Individual wiring, With lead wire
 Length 300 mm

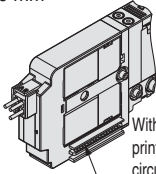

MN: Individual wiring, Without lead wire
 (With connector, socket)

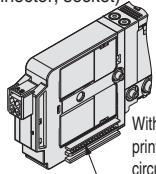

MO: Individual wiring, Without connector

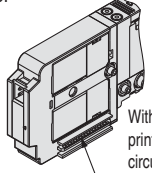

* Connector entries with the symbol "M□" can not use the switch signal from the manifold. For details, refer to "Connector Wiring Diagram" on page 5.
 * When ordering a connector assembly separately, refer to pages 101 and 102.

With switch

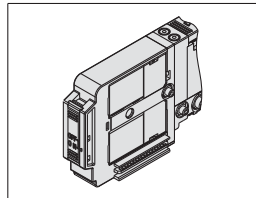

Manual override

—: Non-locking push type

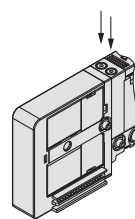

D: Push-turn locking slotted type

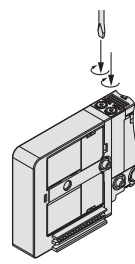

F: Slide locking type

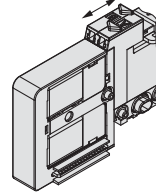

Elbow fitting assembly (Upward entry) (Metric size)

L2: ø2 elbow fitting assembly
L4: ø4 elbow fitting assembly
L6: ø6 elbow fitting assembly (SJ3000 only)

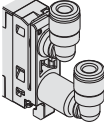

(Inch size)
LN1: ø1/8" elbow fitting assembly
LN3: ø5/32" elbow fitting assembly
LN7: ø1/4" elbow fitting assembly (SJ3000 only)

Elbow fitting assembly (Downward entry) (Metric size)

B2: ø2 elbow fitting assembly
B4: ø4 elbow fitting assembly
B6: ø6 elbow fitting assembly (SJ3000 only)

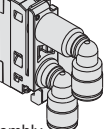

(Inch size)
BN1: ø1/8" elbow fitting assembly
BN3: ø5/32" elbow fitting assembly
BN7: ø1/4" elbow fitting assembly (SJ3000 only)

Note 2) The electrical connection to the manifold will be positive common spec. when light/surge voltage suppressor is "Z" (Polar type).

Protective class class III (Mark: ⚡)

SJ 2000 3000

Common Specifications

Construction

Plug-in

Connector Type/
Cable Type

Non plug-in

Individual Wiring

Manifold Options

Made to Order

SJ3A6

Common Specifications/
Construction

Plug-in

Connector Type/
Cable Type

Non plug-in

Individual Wiring

Manifold Electrical Wiring

Type 60G: Flat ribbon cable (20 pins, PC wiring with power supply terminal)

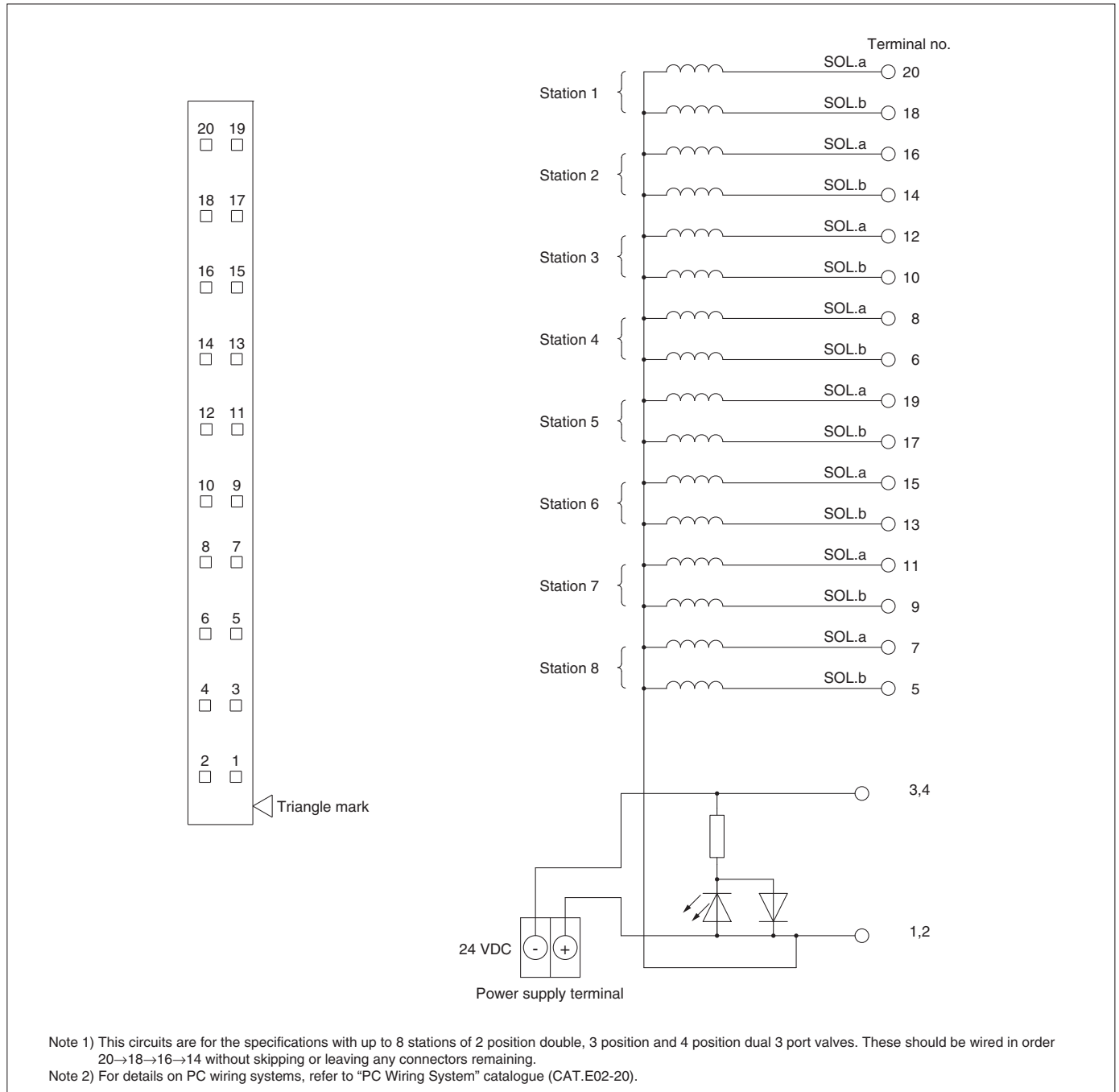

Dimensions

SS5J2-60GD- Stations **U(S, R, RS)**

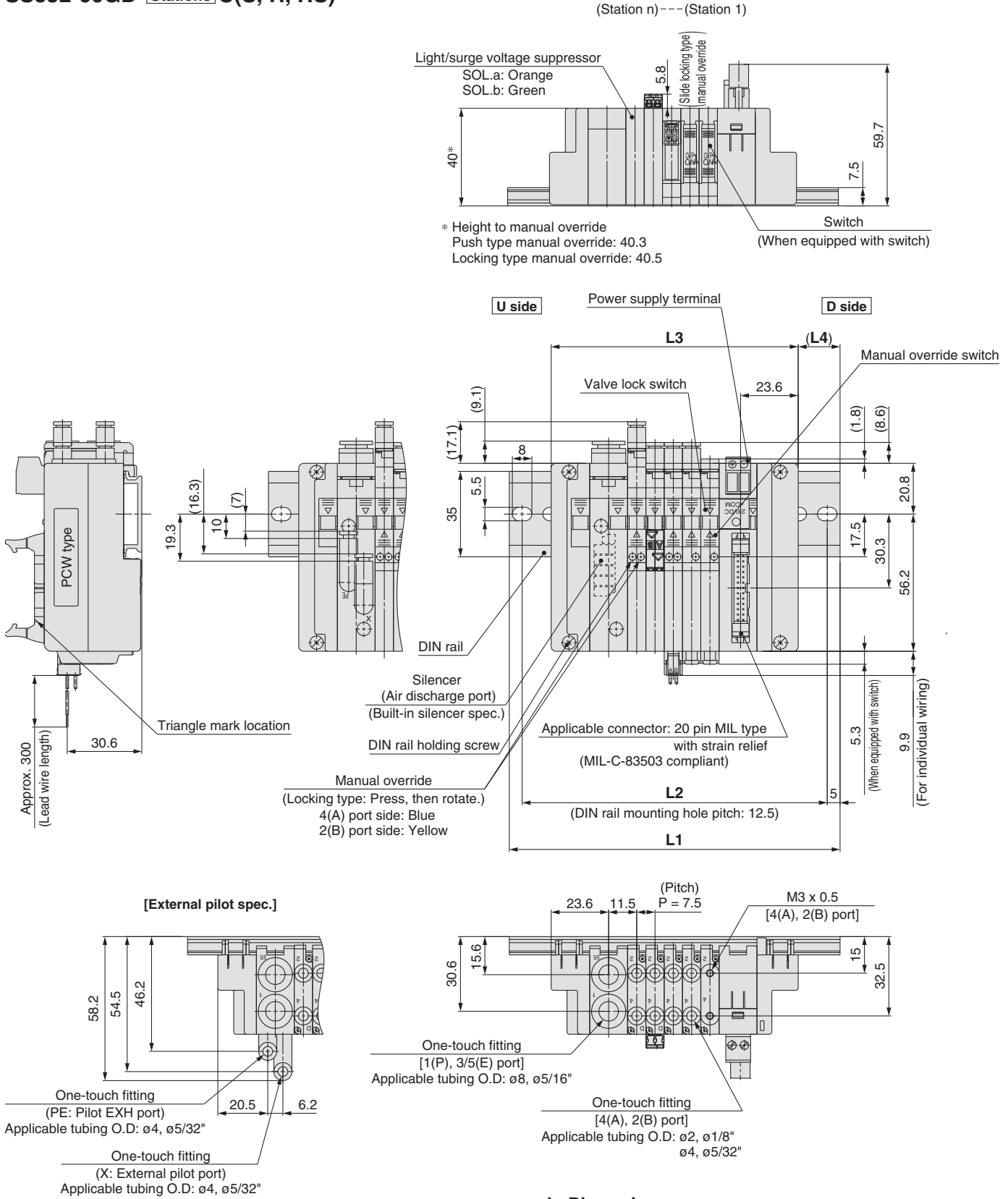

L: Dimensions

		n: Stations									
L	n	1	2	3	4	5	6	7	8	9	10
L1		98	110.5	110.5	123	135.5	135.5	148	148	160.5	173
L2		87.5	100	100	112.5	125	125	137.5	137.5	150	162.5
L3		71.2	78.7	86.2	93.7	101.2	108.7	116.2	123.7	131.2	138.7
L4		13.5	16	12	14.5	17	13.5	16	12	14.5	17

Note) For manifold dimensions including elbow fitting, refer to page 31.

Series SJ2000/3000

Dimensions

SS5J2-60GD- Stations B(S, R, RS)

(Station n) --- (Station 1)

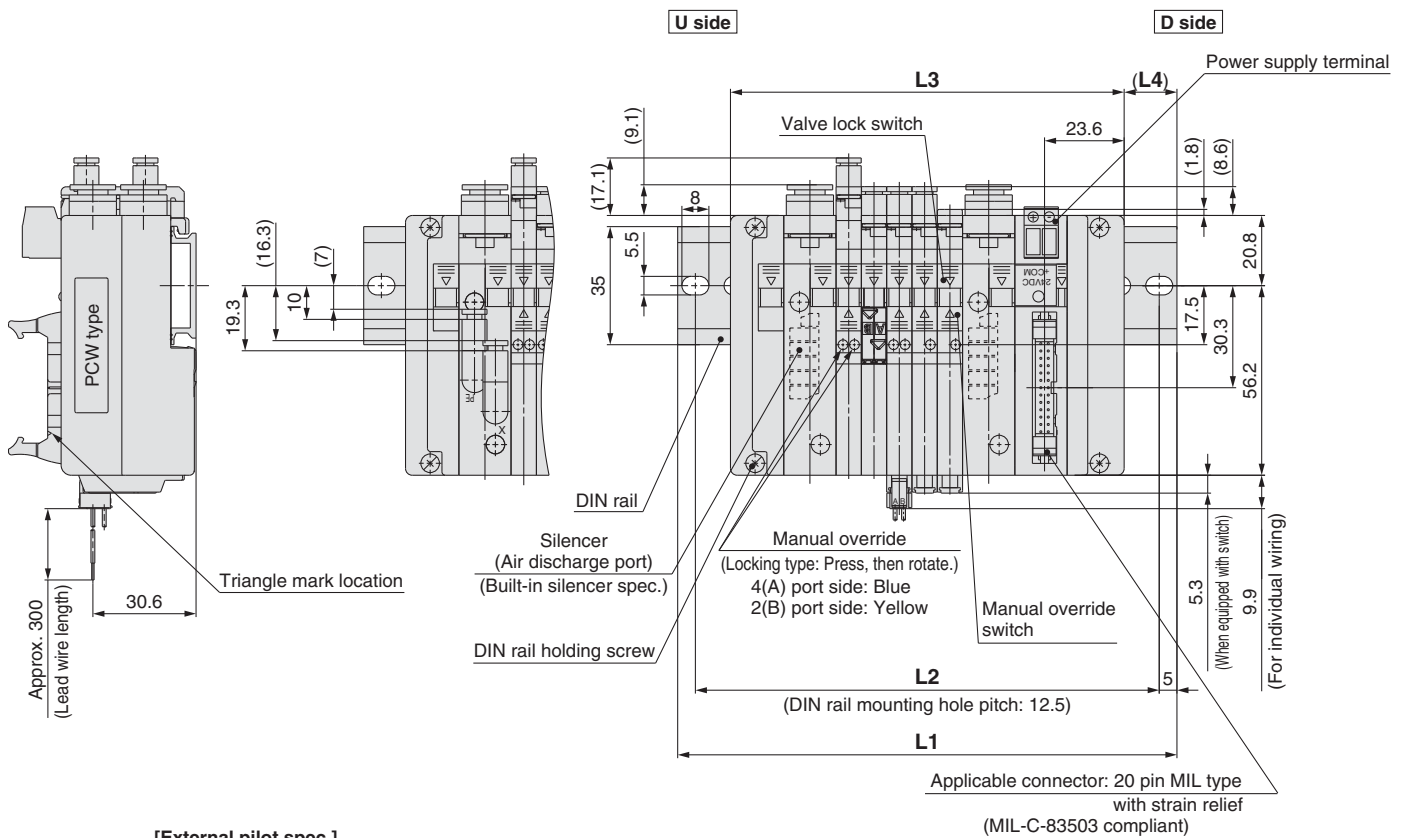
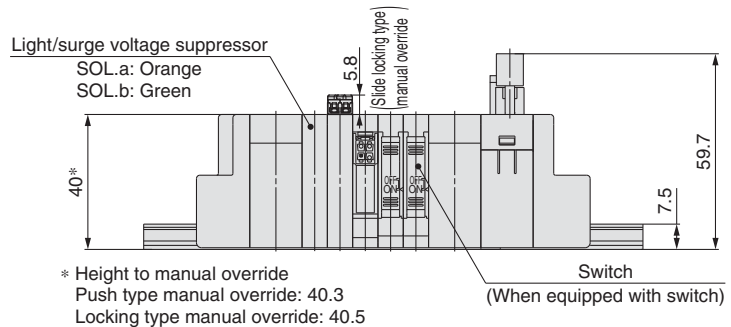

[External pilot spec.]
(There is a piping of X, PE port in the both sides.)

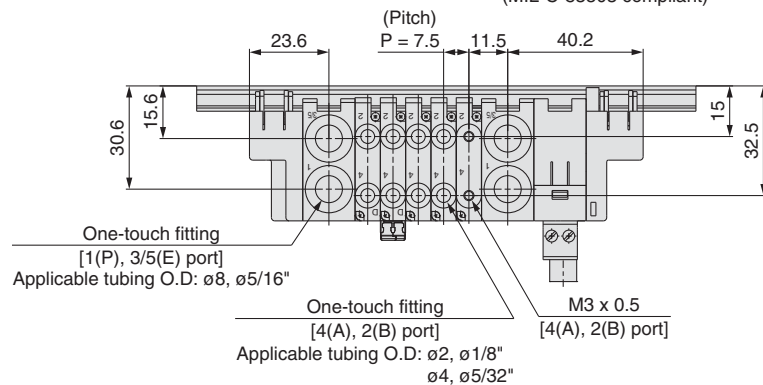
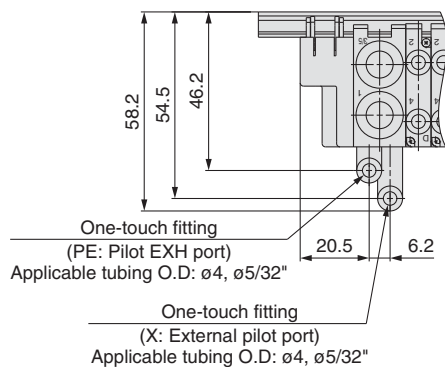

Note) For manifold dimensions including elbow fitting, refer to page 31.

L: Dimensions

n: Stations

L \ n	1	2	3	4	5	6	7	8	9	10	11	12	13	14	15	16
L1	110.5	123	135.5	135.5	148	148	160.5	173	173	185.5	185.5	198	210.5	210.5	223	223
L2	100	112.5	125	125	137.5	137.5	150	162.5	162.5	175	175	187.5	200	200	212.5	212.5
L3	86.7	94.2	101.7	109.2	116.7	124.2	131.7	139.2	146.7	154.2	161.7	169.2	176.7	184.2	191.7	199.2
L4	12	14.5	17	13	15.5	12	14.5	17	13	15.5	12	14.5	17	13	15.5	12

Dimensions

SS5J3-60GD- Stations U(S, R, RS)

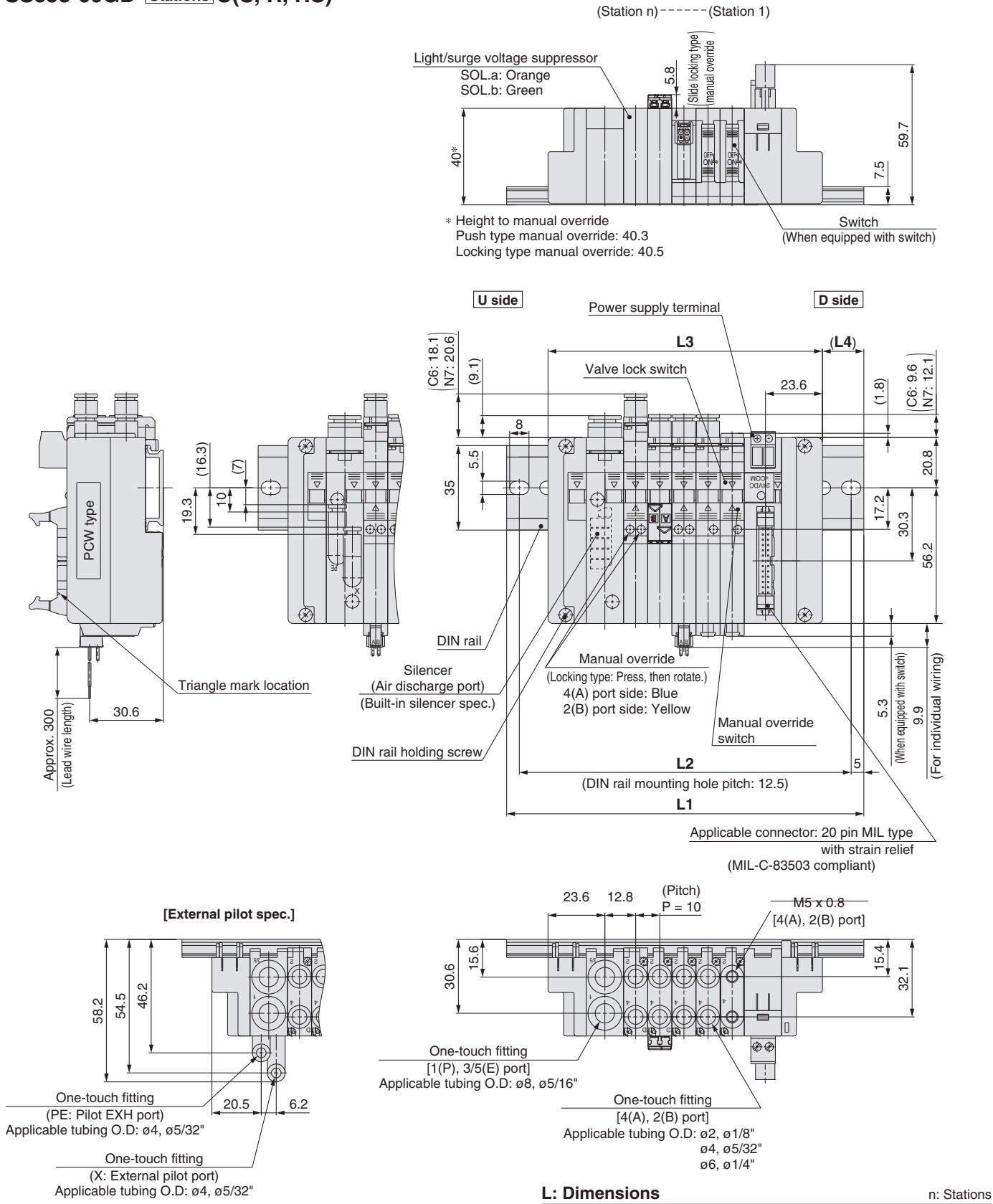

L: Dimensions n: Stations

L \ n	1	2	3	4	5	6	7	8	9	10
L1	98	110.5	123	135.5	148	148	160.5	173	185.5	198
L2	87.5	100	112.5	125	137.5	137.5	150	162.5	175	187.5
L3	73.7	83.7	93.7	103.7	113.7	123.7	133.7	143.7	153.7	163.7
L4	12	13	14.5	15.5	16.5	11.5	12.5	14	15	16

Note) For manifold dimensions including elbow fitting, refer to page 32.

SJ 2000 3000
Common Specifications
Construction
Plug-in
Connector Type/
Cable Type
Non plug-in
Individual
Wiring
Manifold
Options
Made to
Order
SJ3A6
Common Specifications/
Construction
Plug-in
Connector Type/
Cable Type
Non plug-in
Individual
Wiring

Series SJ2000/3000

Dimensions

SS5J3-60GD- Stations B(S, R, RS)

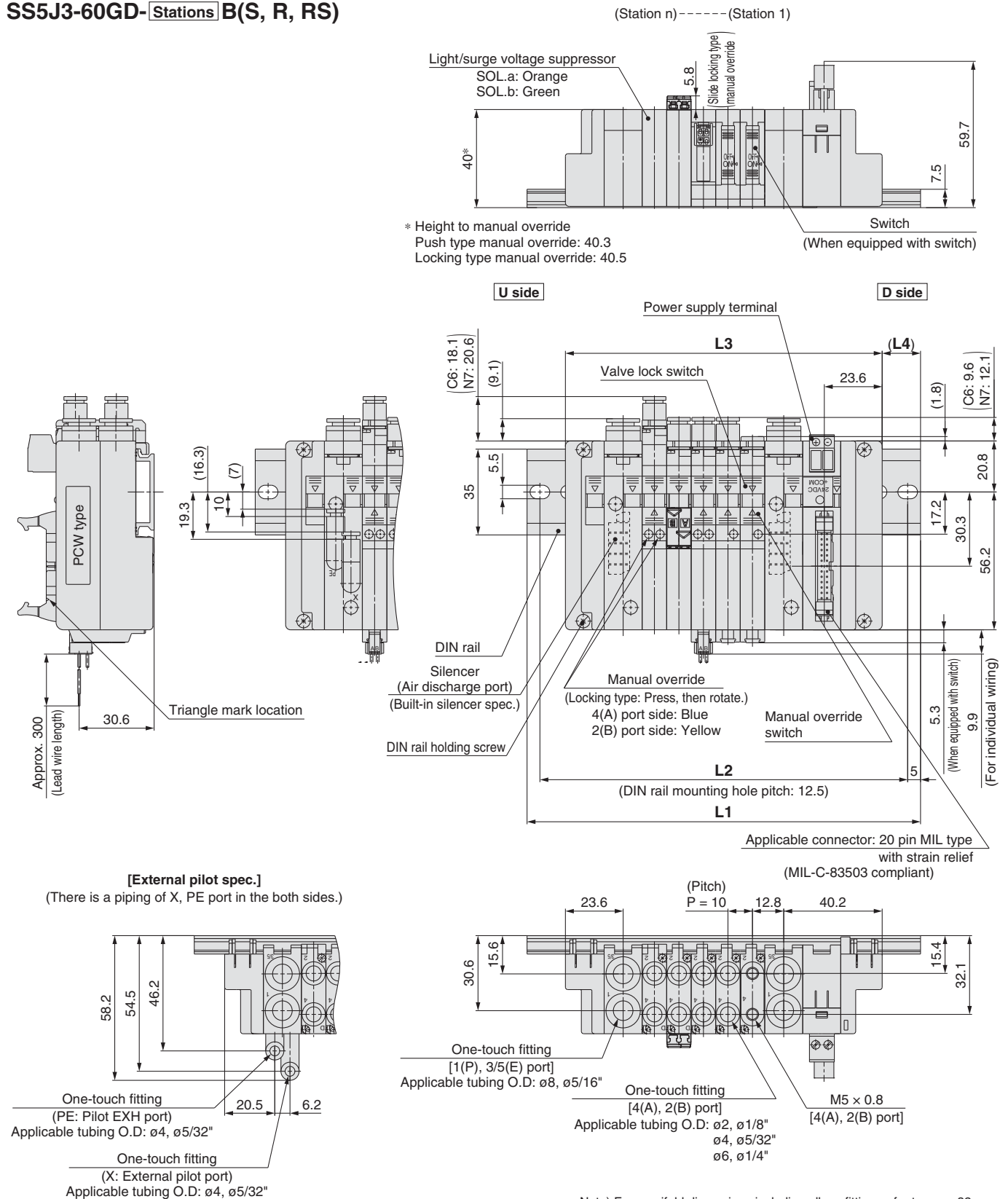

L: Dimensions

n: Stations

L \ n	1	2	3	4	5	6	7	8	9	10	11	12	13	14	15	16
L1	123	123	135.5	148	160.5	173	185.5	185.5	198	210.5	223	235.5	235.5	248	260.5	273
L2	112.5	112.5	125	137.5	150	162.5	175	175	187.5	200	212.5	225	225	237.5	250	262.5
L3	89.2	99.2	109.2	119.2	129.2	139.2	149.2	159.2	169.2	179.2	189.2	199.2	209.2	219.2	229.2	239.2
L4	17	11.5	13	14	15	16.5	17.5	12.5	13.5	14.5	16	17	12	13	14	15.5

Dimensions

SS5J3-M60GD- Stations U(S, R, RS)

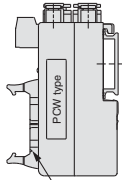

Triangle mark location

L dimension: Formula, L1 to L4
 $L3 = 7.5 \times n1 + 10 \times n2 + 63.7$
 $M = (L3 + 4) / 12.5 + 1$
 Remove all numbers after the decimal.
 $L1 = M \times 12.5 + 23$
 $L2 = L1 - 10.5$
 $L4 = (L1 - L3) / 2 - 2$

n1: Quantity of SJ2000
 n2: Quantity of SJ3000

* The dimensions of L1 to L4 for **SS5J3-M60GD- Stations D** are the same as those of **SS5J3-M60GD- Stations U**.

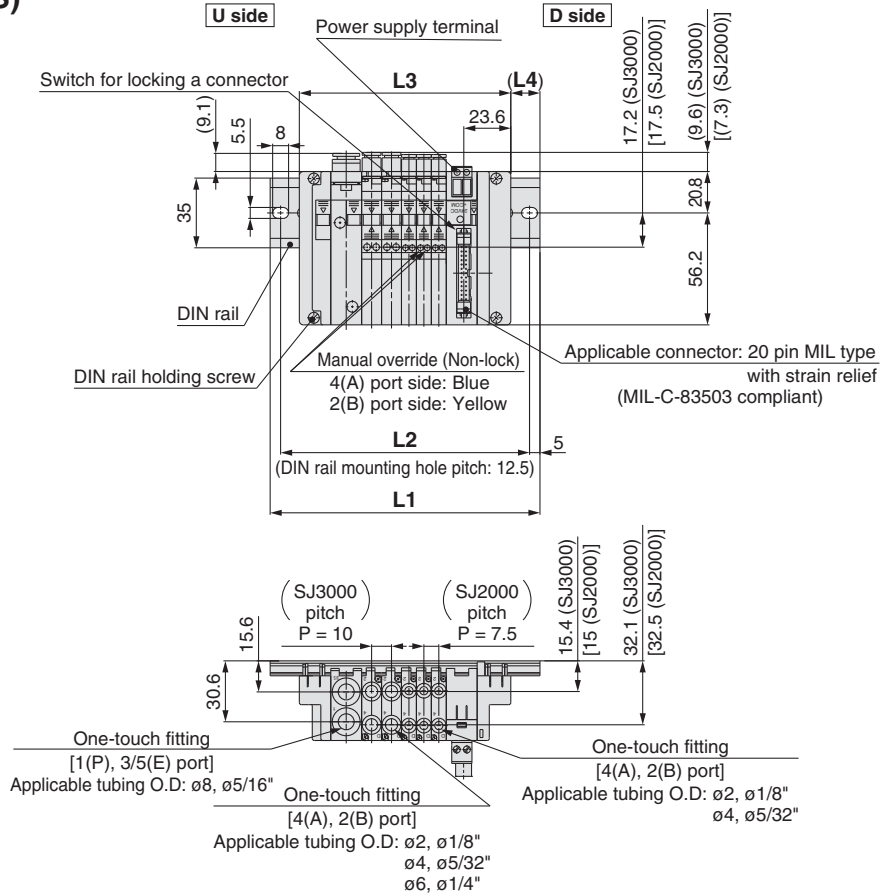

SS5J3-M60GD- Stations B(S, R, RS)

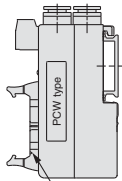

Triangle mark location

L dimension: Formula, L1 to L4
 $L3 = 7.5 \times n1 + 10 \times n2 + 79.2$
 $M = (L3 + 4) / 12.5 + 1$
 Remove all numbers after the decimal.
 $L1 = M \times 12.5 + 23$
 $L2 = L1 - 10.5$
 $L4 = (L1 - L3) / 2 - 2$

n1: Quantity of SJ2000
 n2: Quantity of SJ3000

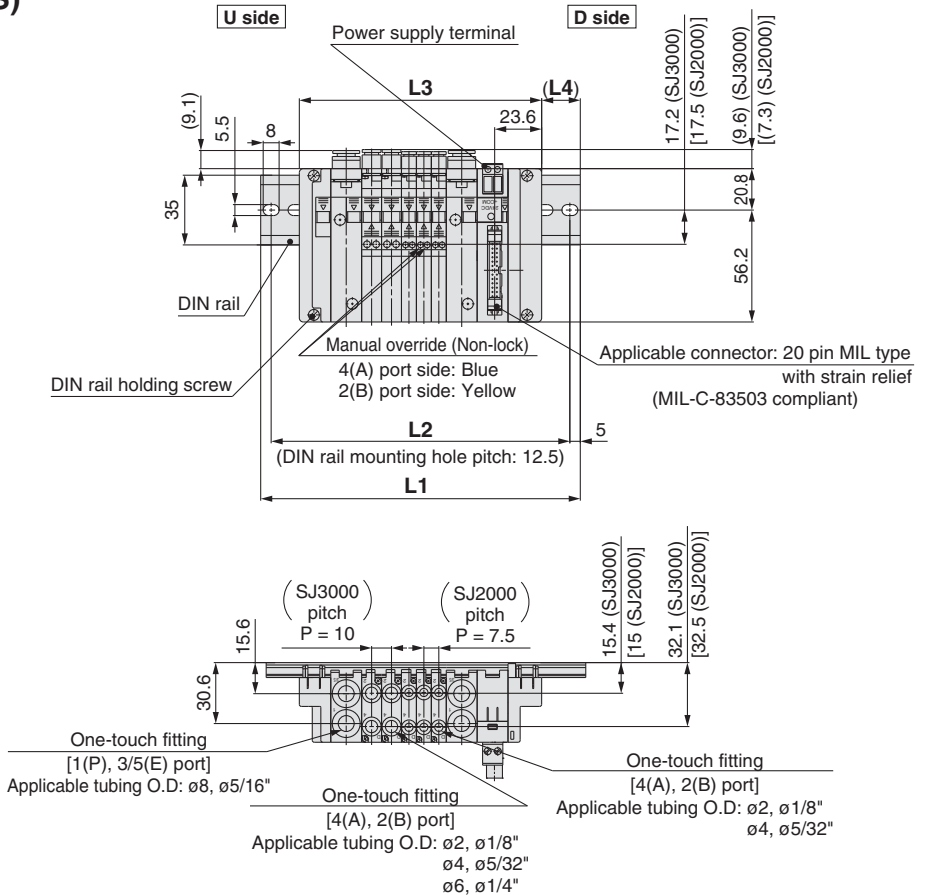

Plug-in Connector Type EX180 Integrated Type (for Output) Serial Transmission System Series SJ2000/3000



Type 60S

An order cannot be placed with only the manifold part no. Be sure to order solenoid valves for mounting at the same time while referring to the ordering example.

How to Order

SS5J3-60SV2-D-05U

Series

2	SJ2000
3	SJ3000 (SJ2000/3000 mixed)

Mixed mounting type

—	Standard (Note 1)
M	Mixed mounting (Note 2)

Note 1) There is no need to enter anything when you operate either the SJ2000 or SJ3000 series alone.
Note 2) Enter "M" when the SJ2000 or SJ3000 series will be mounted on the same manifold base together.

Component module

0	Without SI unit
V2	CC-Link compliant (32 points)
Q2	DeviceNet compliant (32 points)
Q3	DeviceNet compliant (16 points)

* Please contact SMC for a specification of the SI unit.

Communication connector spec.

—	T-branch type
A	Straight type

* Communication connector, power connector are shipped together with manifold. Power connector is available of straight type only.

SI unit common spec.

—	Positive common
N	Negative common

Unit mounting position

D	D side
---	--------

Valve stations

Symbol	Stations	Note
01	1 station	Up to 32 solenoids possible.
⋮	⋮	
32	32 stations	

* The number of the blanking block assembly is also included. Since single and double wiring are available with the blanking block assembly, select a model compatible with the valve wiring spec. planned for the future. (Refer to page 70.)

DIN rail length specified

—	Standard length	Specify a longer rail than the standard length.
2	2 stations	
32	32 stations	

* Specify the valve stations not exceeding the maximum stations.

SUP/EXH block fitting spec.

—	Straight fitting	
L	Elbow fitting (Upward)	
B	Elbow fitting (Downward)	

* There is no need to enter anything when the SUP/EXH block mounting position "M" is selected.

Pilot spec.

—	Internal pilot
S	Internal pilot/Built-in silencer
R	External pilot
RS	External pilot/Built-in silencer

* There is no need to enter anything when the SUP/EXH block mounting position "M" is selected.
* For built-in silencers, the 3/5(E) ports are plugged.

How to Order Manifold Assembly

Ordering example (SS5J3-60SV2-D-05U)

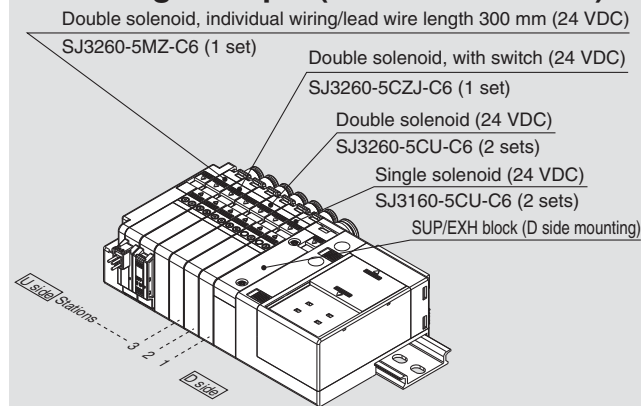

SS5J3-60SV2D-06D ...1 set (Manifold part no.)
 * SJ3160-5CU-C6 2 sets (Single solenoid part no.)
 * SJ3260-5CU-C6 2 sets (Double solenoid part no.)
 * SJ3260-5CZJ-C6 1 set (Double solenoid, with switch part no.)
 * SJ3260-5MZ-C6 1 set (Double solenoid, individual wiring/lead wire length 300 mm part no.)

The asterisk denotes the symbol for assembly. Prefix to the part no. of the solenoid valve, etc.

• The valve arrangement is numbered as the 1st station from D side.
 • Indicate the valves to be attached below the manifold part number, in order starting from station 1 as shown in the drawing. In the case of complex arrangement, specify them in the manifold specification sheet.
 Note) When ordering a manifold, specify the part nos. of valves to be mounted together. (An order cannot be placed with only the manifold part no.)

SUP/EXH block mounting position

U	U side (1 to 10 stations)
D	D side (1 to 10 stations)
B	Both sides (1 to 32 stations)
M*	Special specifications

* Specify the required specifications (including port sizes other than ø8) by means of the manifold specification sheet.

SI Unit Part No.

Symbol	Component module/Communication connector specifications	Common spec.	SI unit part no.
V2	CC-LINK compliant	NPN output (Positive common)	EX180-SMJ3
V2N	(32 points), T-branch type	PNP output (Negative common)	EX180-SMJ5
V2A	CC-LINK compliant	NPN output (Positive common)	EX180-SMJ3A
V2AN	(32 points), Straight type	PNP output (Negative common)	EX180-SMJ5A
Q2	DeviceNet compliant	NPN output (Positive common)	EX180-SDN3
Q2N	(32 points), T-branch type	PNP output (Negative common)	EX180-SDN5
Q2A	DeviceNet compliant	NPN output (Positive common)	EX180-SDN3A
Q2AN	(32 points), Straight type	PNP output (Negative common)	EX180-SDN5A
Q3	DeviceNet compliant	NPN output (Positive common)	EX180-SDN4
Q3N	(16 points), T-branch type	PNP output (Negative common)	EX180-SDN6
Q3A	DeviceNet compliant	NPN output (Positive common)	EX180-SDN4A
Q3AN	(16 points), Straight type	PNP output (Negative common)	EX180-SDN6A

Item		Specifications
Power source	Non-polar	24 VDC + 10%/–5%
for driving valve	With energy saving circuit (Continuous duty)	24 VDC + 10%/0%

Refer to Reduced Wiring Fieldbus System (Serial Transmission) in Electric Products (CAT.E150) and the Operation Manual for the details of EX180 integrated-type (for output) serial transmission system. Please download it via our website. <http://www.smc.eu>



How to Order Solenoid Valves

Standard

SJ 3 1 60 [] [] [] - 5 [] C U [] - C6 - []

With switch

SJ 3 1 60 [] [] [] - 5 [] C Z J [] - C6 - []

Individual wiring
[For plug-in mixed mounting]^{Note 1)}

SJ 3 1 60 [] [] [] - 5 [] M Z [] - C6

Note 1) Refer to pages 61 and 62 for the dedicated non plug-in individual wiring.

Series

2	SJ2000
3	SJ3000

Back pressure check valve

-	None
K	Built-in

* Back pressure check valve is not applicable for 3 position solenoid valve.

Rated voltage

5	24 VDC
---	--------

Common specifications

-	Positive common
N	Negative common

Single solenoid wiring spec.

-	Single wiring
D	Double wiring

* There is no need to enter anything for 2 position double, 3 position and 4 position solenoid valves. Select this when the unused numbers to wiring are set. Refer to page 5 for details.

Type of actuation

1	2 position single solenoid
2	2 position double solenoid
3	3 position closed centre
4	3 position exhaust centre
5	3 position pressure centre
A	Dual 3 port valve: N.C./N.C.
B	Dual 3 port valve: N.O./N.O.
C	Dual 3 port valve: N.C./N.O.

* Refer to pages 6 through to 13 for the Symbol.

Pilot spec.

-	Internal pilot
R	External pilot

* External pilot spec. is not applicable for 4 position dual 3 port valves.

Coil spec.

-	Standard
T	With power saving circuit (Continuous duty type)

* Be sure to select "with power saving circuit" when the solenoid valve will be energised continuously for long period.

* For the non-polar type, there is no need to select a symbol.
* When equipped with the standard type switch, select common specifications suitable for the SI unit common specifications.

Light/surge voltage suppressor

U	With light/surge voltage suppressor (Non-polar type)
Z	With light/surge voltage suppressor (Polar type)

* When the types with power saving circuit, with switches, and/or individual wiring are used, the non-polar type cannot be selected.

A, B port size

Straight (Metric size)

- C2: ø2 One-touch fitting
- C4: ø4 One-touch fitting
- C6: ø6 One-touch fitting (SJ3000 only)

(Inch size)

- N1: ø1/8" One-touch fitting
- N3: ø5/32" One-touch fitting
- N7: ø1/4" One-touch fitting (SJ3000 only)

- M3: M3 x 0.5 (SJ2000 only)
- M5: M5 x 0.8 (SJ3000 only)

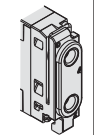
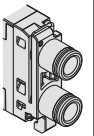

C: Dedicated for centralised wiring

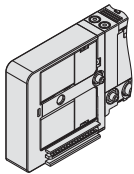

M: Individual wiring, With lead wire Length 300 mm

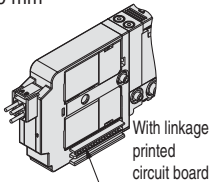

MN: Individual wiring, Without lead wire (With connector, socket)

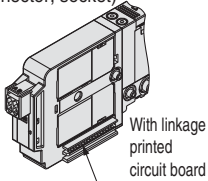

MO: Individual wiring, Without connector

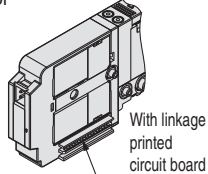

* Connector entries with the symbol "M□" can not use the switch signal from the common wiring on the manifold. For details, refer to "Connector Wiring Diagram" on page 5.
* When ordering a connector assembly separately, refer to pages 101 and 102.

With switch

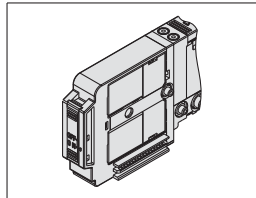

Manual override

-: Non-locking push type

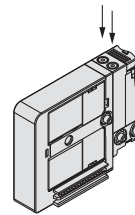

D: Push-turn locking slotted type

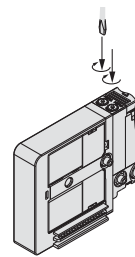

F: Slide locking type

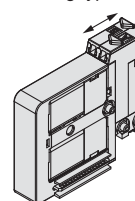

Elbow fitting assembly (Upward entry)

(Metric size)

- L2: ø2 elbow fitting assembly
- L4: ø4 elbow fitting assembly
- L6: ø6 elbow fitting assembly (SJ3000 only)

(Inch size)

- LN1: ø1/8" elbow fitting assembly
- LN3: ø5/32" elbow fitting assembly
- LN7: ø1/4" elbow fitting assembly (SJ3000 only)

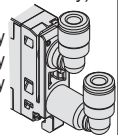

Elbow fitting assembly (Downward entry)

(Metric size)

- B2: ø2 elbow fitting assembly
- B4: ø4 elbow fitting assembly
- B6: ø6 elbow fitting assembly (SJ3000 only)

(Inch size)

- BN1: ø1/8" elbow fitting assembly
- BN3: ø5/32" elbow fitting assembly
- BN7: ø1/4" elbow fitting assembly (SJ3000 only)

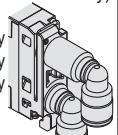

Note 2) The electrical connection to the manifold will be positive common spec. when light/surge voltage suppressor is "Z" (Polar type).

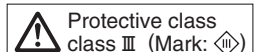

SJ 2000 3000

Common Specifications

Construction

Plug-in

Connector Type/ Cable Type

Non plug-in

Individual Wiring

Manifold Options

Made to Order

SJ3A6

Common Specifications/ Construction

Plug-in

Connector Type/ Cable Type

Non plug-in

Individual Wiring

Series SJ2000/3000

Dimensions: Series SJ2000 for EX180 Integrated Type (for Output) Serial Transmission System

SS5J2-60S □ □ - Stations U(S, R, RS)

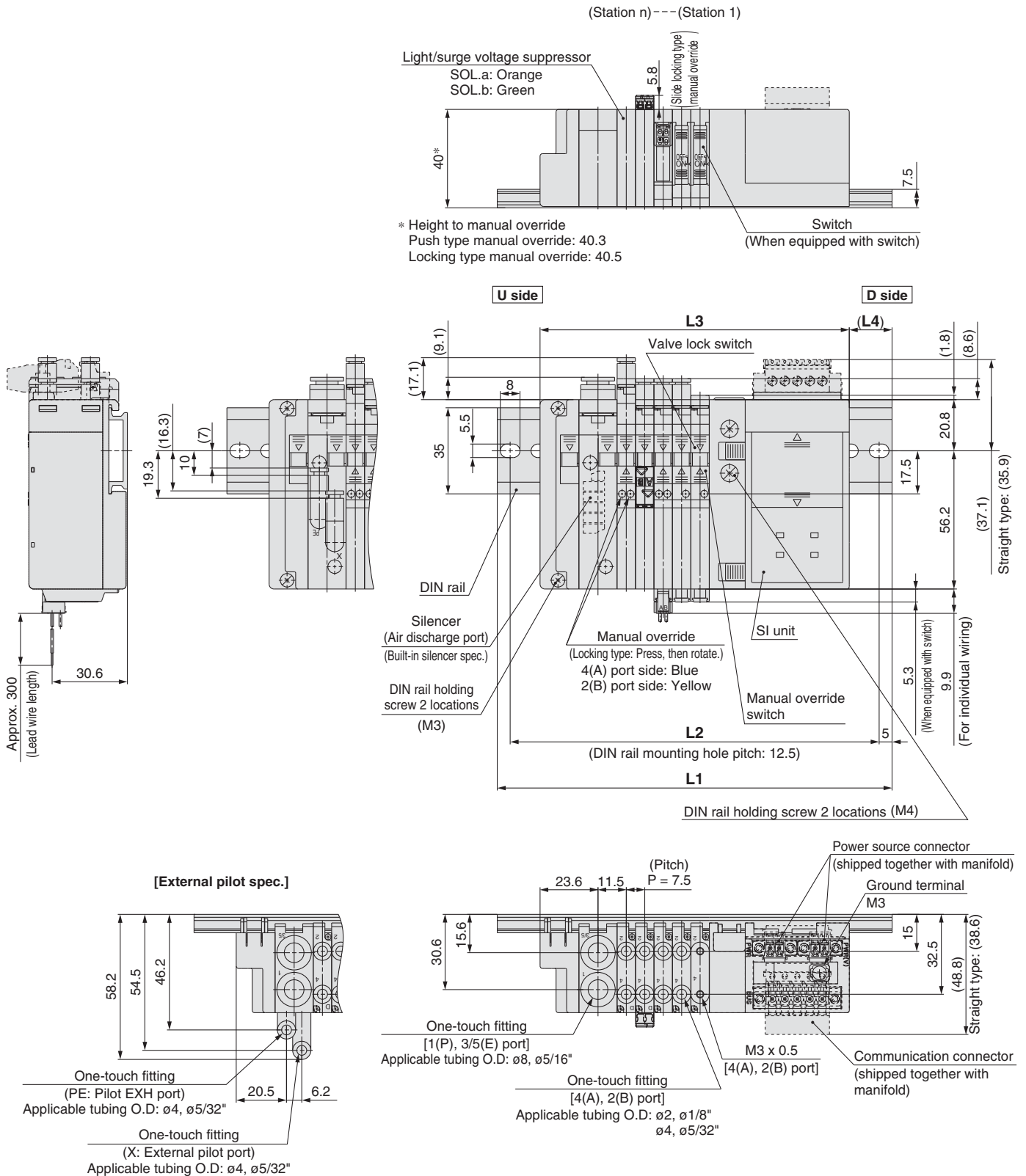

L: Dimensions

n: Stations

L ⁿ	1	2	3	4	5	6	7	8	9	10
L1	123	135.5	135.5	148	160.5	160.5	173	173	185.5	198
L2	112.5	125	125	137.5	150	150	162.5	162.5	175	187.5
L3	95.7	103.2	110.7	118.2	125.7	133.2	140.7	148.2	155.7	163.2
L4	13.5	16	12.5	15	17.5	13.5	16	12.5	15	17.5

Note) Refer to page 31 for the dimensions of the manifold with elbow fittings and pages 1658 to 1660 of Best Pneumatics No.1 for the details of SI unit.

Dimensions: Series SJ2000 for EX180 Integrated Type (for Output) Serial Transmission System

SS5J2-60S □□ - Stations B(S, R, RS)

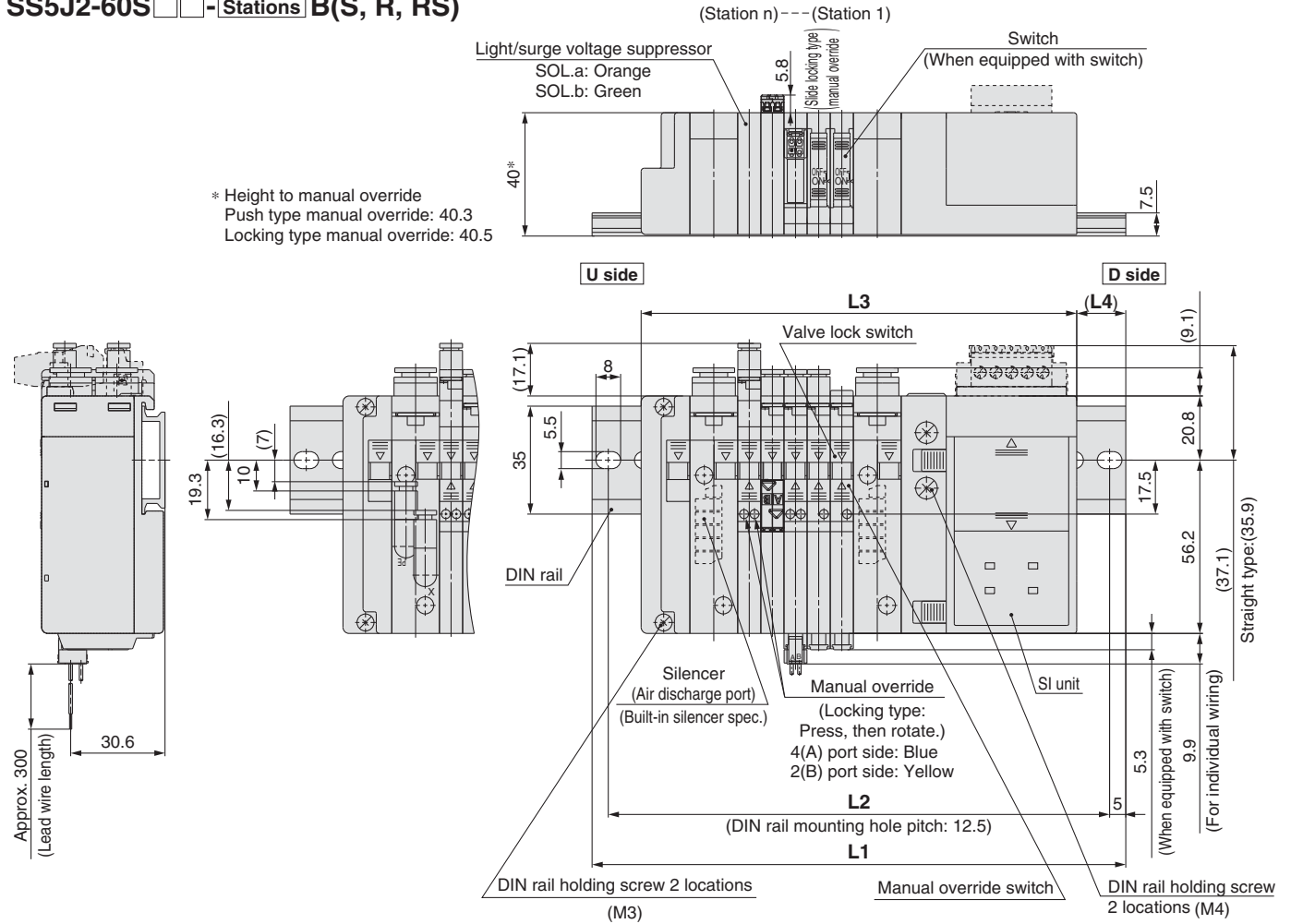

[External pilot spec.]
(There is a piping of X, PE port in the both sides.)

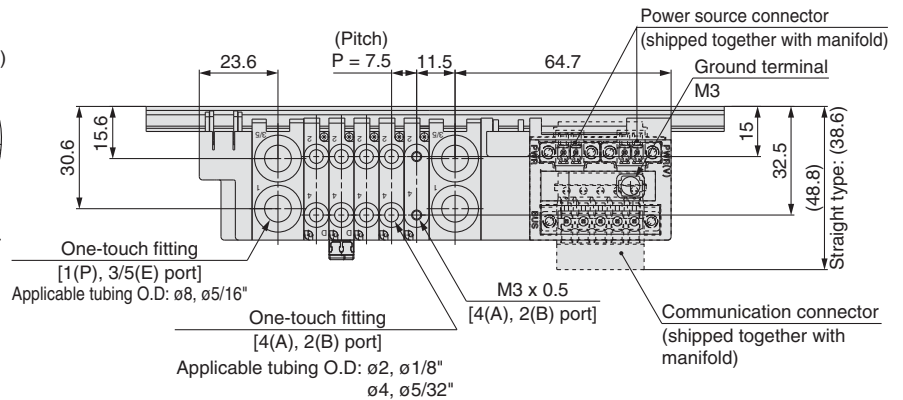
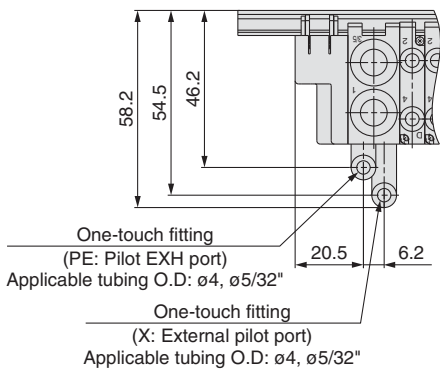

L: Dimensions

n: Stations

L \ n	1	2	3	4	5	6	7	8	9	10	11	12	13	14	15	16
L1	135.5	148	160.5	160.5	173	173	185.5	198	198	210.5	210.5	223	235.5	235.5	248	248
L2	125	137.5	150	150	162.5	162.5	175	187.5	187.5	200	200	212.5	225	225	237.5	237.5
L3	111.2	118.7	126.2	133.7	141.2	148.7	156.2	163.7	171.2	178.7	186.2	193.7	201.2	208.7	216.2	223.7
L4	12	14.5	17	13.5	16	12	14.5	17	13.5	16	12	14.5	17	13.5	16	12
L \ n	17	18	19	20	21	22	23	24	25	26	27	28	29	30	31	32
L1	260.5	273	273	285.5	285.5	298	310.5	310.5	323	323	335.5	348	348	360.5	360.5	373
L2	250	262.5	262.5	275	275	287.5	300	300	312.5	312.5	325	337.5	337.5	350	350	362.5
L3	231.2	238.7	246.2	253.7	261.2	268.7	276.2	283.7	291.2	298.7	306.2	313.7	321.2	328.7	336.2	343.7
L4	14.5	17	13.5	16	12	14.5	17	13.5	16	12	14.5	17	13.5	16	12	14.5

Note) Refer to page 31 for the dimensions of the manifold with elbow fittings and pages 1658 to 1660 of Best Pneumatics No.1 for the details of SI unit.

Series SJ2000/3000

Dimensions: Series SJ3000 for EX180 Integrated Type (for Output) Serial Transmission System

SS5J3-60S □□ - Stations U(S, R, RS)

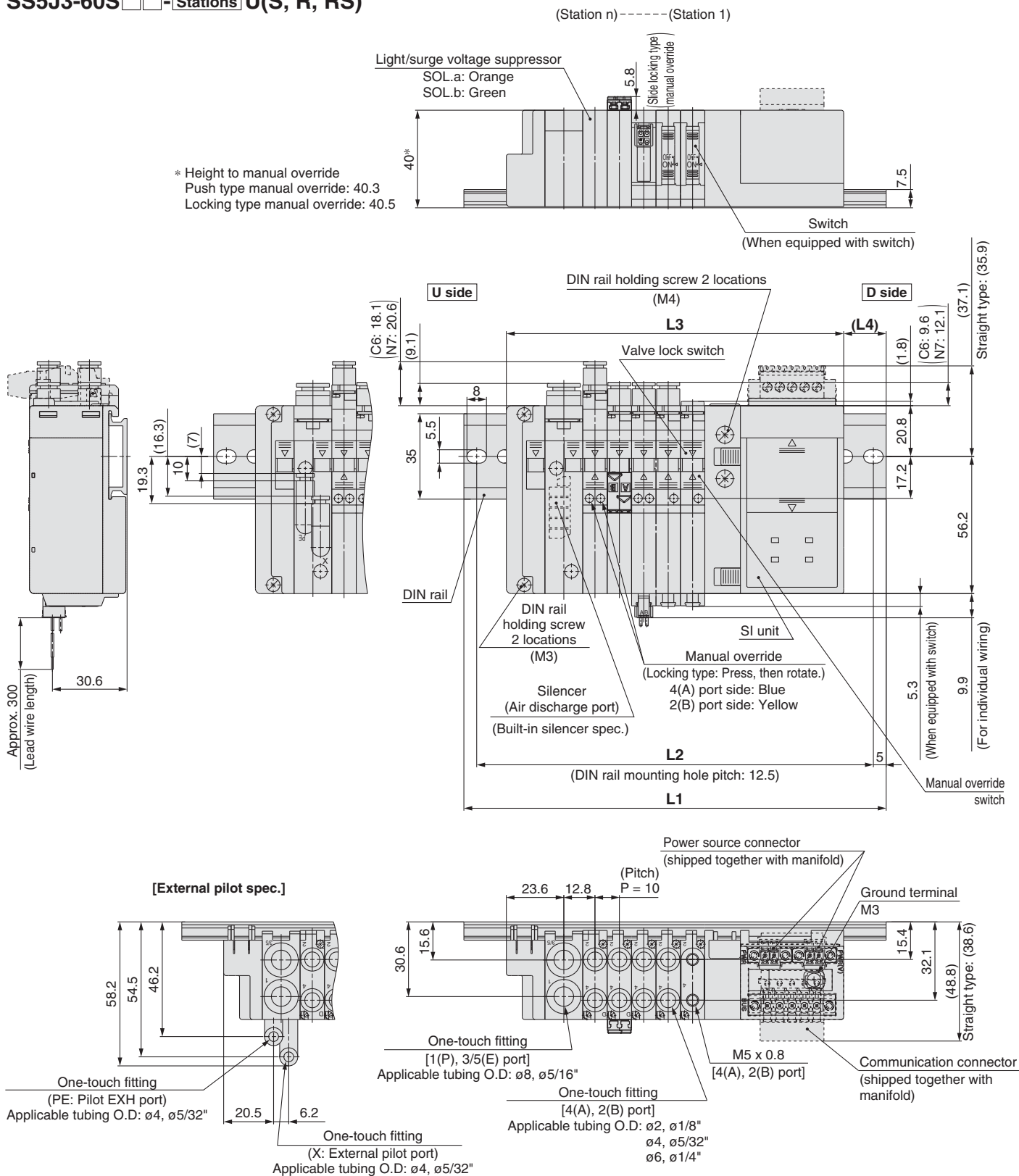

L: Dimensions

n: Stations

L \ n	1	2	3	4	5	6	7	8	9	10
L1	123	135.5	148	160.5	173	173	185.5	198	210.5	223
L2	112.5	125	137.5	150	162.5	162.5	175	187.5	200	212.5
L3	98.2	108.2	118.2	128.2	138.2	148.2	158.2	168.2	178.2	188.2
L4	12.5	13.5	14.5	16	17	12	13	14	15.5	16.5

Note) Refer to page 32 for the dimensions of the manifold with elbow fittings and pages 1658 to 1660 of Best Pneumatics No.1 for the details of SI unit.

Dimensions: Series SJ3000 for EX180 Integrated Type (for Output) Serial Transmission System

SS5J3-60S □□ - Stations B(S, R, RS)

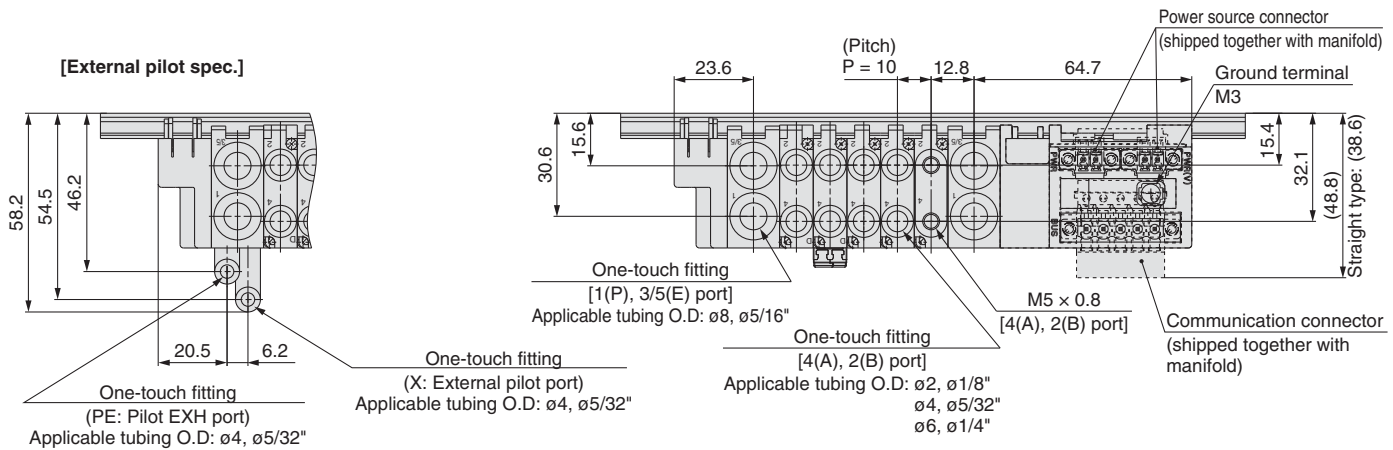
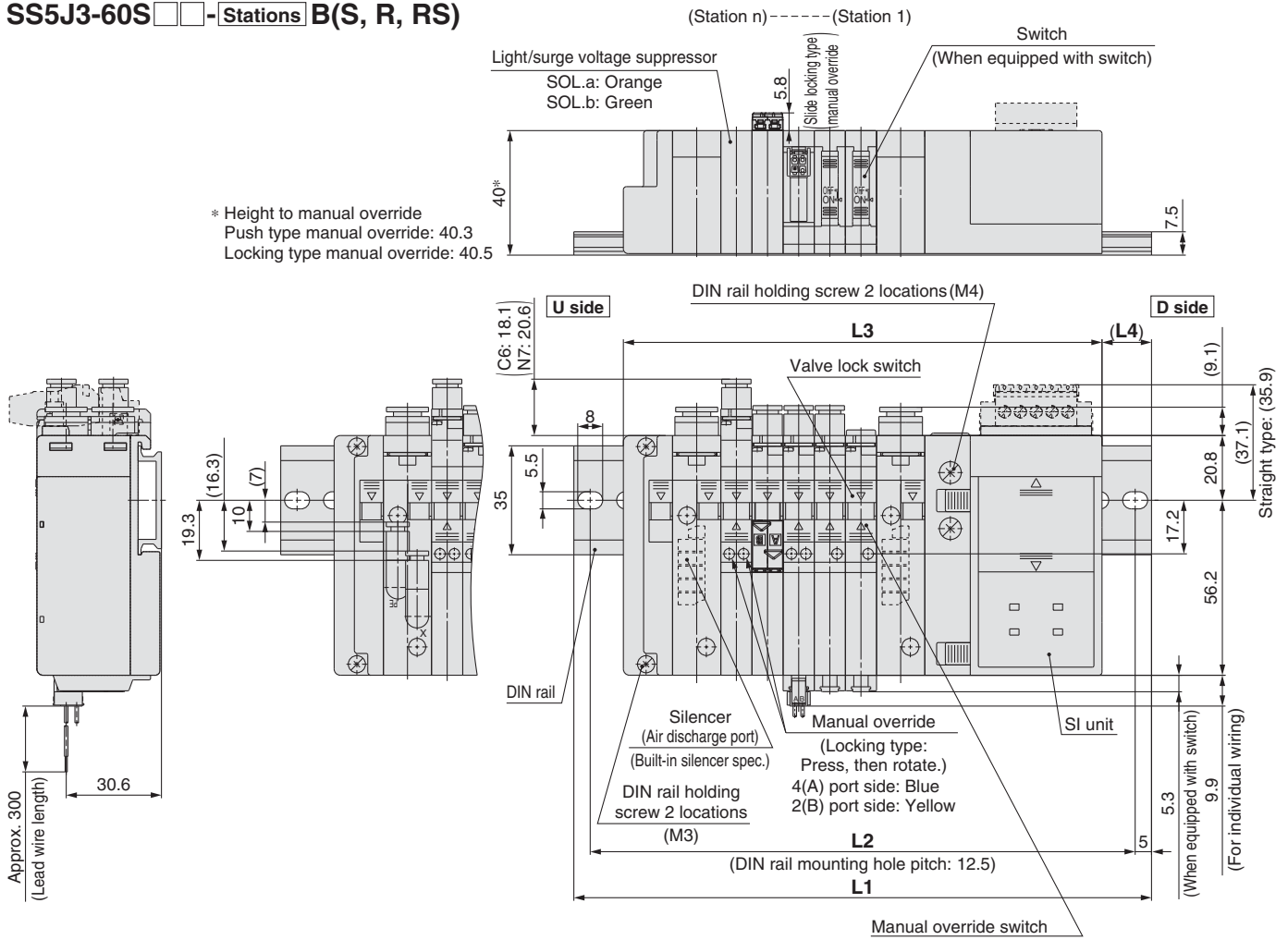

L: Dimensions

		n: Stations															
L	n	1	2	3	4	5	6	7	8	9	10	11	12	13	14	15	16
L1		148	148	160.5	173	185.5	198	210.5	210.5	223	235.5	248	260.5	260.5	273	285.5	298
L2		137.5	137.5	150	162.5	175	187.5	200	200	212.5	225	237.5	250	250	262.5	275	287.5
L3		113.7	123.7	133.7	143.7	153.7	163.7	173.7	183.7	193.7	203.7	213.7	223.7	233.7	243.7	253.7	263.7
L4		17	12	13	14.5	15.5	16.5	17.5	12.5	14	15	16	17	12	13.5	14.5	15.5
L	n	17	18	19	20	21	22	23	24	25	26	27	28	29	30	31	32
L1		310.5	310.5	323	335.5	348	360.5	373	373	385.5	398	410.5	423	423	435.5	448	460.5
L2		300	300	312.5	325	337.5	350	362.5	362.5	375	387.5	400	412.5	412.5	425	437.5	450
L3		273.7	283.7	293.7	303.7	313.7	323.7	333.7	343.7	353.7	363.7	373.7	383.7	393.7	403.7	413.7	423.7
L4		16.5	11.5	13	14	15	16	17.5	12.5	13.5	14.5	15.5	17	12	13	14	15

Note) Refer to page 32 for the dimensions of the manifold with elbow fittings and pages 1658 to 1660 of Best Pneumatics No.1 for the details of SI unit.

SJ 2000 3000
 Common Specifications
 Construction
 Plug-in
 Connector Type/
 Cable Type
 Non plug-in
 Individual
 Wiring
 Manifold
 Options
 Made to
 Order
 SJ3A6
 Common Specifications/
 Construction
 Plug-in
 Connector Type/
 Cable Type
 Non plug-in
 Individual
 Wiring

Series SJ2000/3000

Dimensions: SJ2000/3000 Mixed Manifold

SS5J3-M60S □□ - Stations U(S, R, RS)

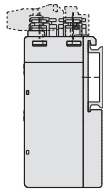

L dimension: Formula, L1 to L4
 $L3 = 7.5 \times n1 + 10 \times n2 + 88.2$
 $M = (L3 + 4) / 12.5 + 1$
 Remove all numbers after the decimal.
 $L1 = M \times 12.5 + 23$
 $L2 = L1 - 10.5$
 $L4 = (L1 - L3) / 2 - 2$

n1: Quantity of SJ2000
 n2: Quantity of SJ3000

* The dimensions of L1 to L4 for SS5J3-M60S □□ - Stations D are the same as those of SS5J3-M60S □□ - Stations U.

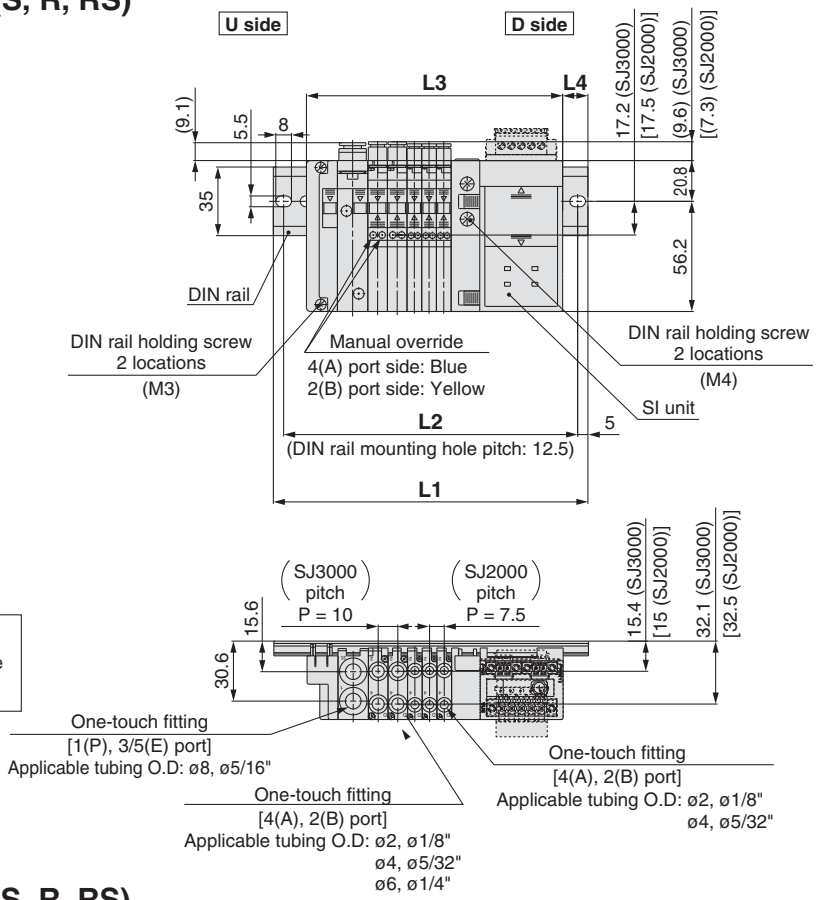

SS5J3-M60S □□ - Stations B(S, R, RS)

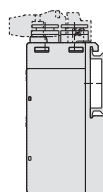

L dimension: Formula, L1 to L4
 $L3 = 7.5 \times n1 + 10 \times n2 + 103.7$
 $M = (L3 + 4) / 12.5 + 1$
 Remove all numbers after the decimal.
 $L1 = M \times 12.5 + 23$
 $L2 = L1 - 10.5$
 $L4 = (L1 - L3) / 2 - 2$

n1: Quantity of SJ2000
 n2: Quantity of SJ3000

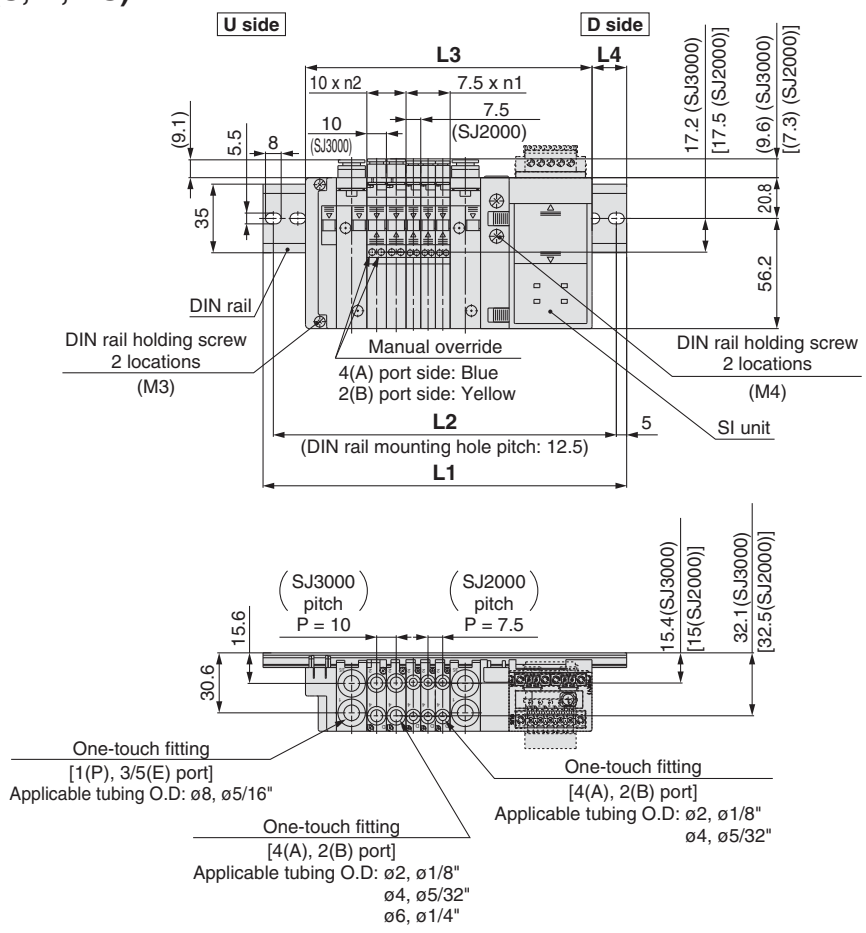

Individual Wiring	Non plug-in	Connector Type/ Cable Type	Plug-in	Common Specifications/ Construction	SJ3A6	Made to Order	Manifold Options	Individual Wiring	Non plug-in	Connector Type/ Cable Type	Plug-in	Construction	Common Specifications	SJ 2000 3000
-------------------	-------------	-------------------------------	---------	--	-------	---------------	------------------	-------------------	-------------	-------------------------------	---------	--------------	-----------------------	--------------------

Plug-in Connector Type EX510 Gateway System Serial Transmission System



Type **60S6B**

Series **SJ2000/3000**

An order cannot be placed with only the manifold part no. Be sure to order solenoid valves for mounting at the same time while referring to the ordering example.

How to Order Manifold

SS5J 3 - 60S6B D - 05 D

Manifold series

2	SJ2000
3	SJ3000 (SJ2000/3000 mixed)

Mixed mounting type

—	Standard ^{Note 1)}
M	Mixed mounting ^{Note 2)}

Note 1) There is no need to enter anything when you operate either the SJ2000 or SJ3000 series alone.

Note 2) Enter "M" when the SJ2000 or SJ3000 series will be mounted on the same manifold base together.

SI unit common spec.

—	Positive common
N	Negative common

Unit mounting position

D	D side
---	--------

Valve stations

Symbol	No. of stations	Note
01	1 station	Up to 16 solenoids possible.
⋮	⋮	
16	16 stations	

* The number of the blanking block assembly is also included. Since single and double wiring are available with the blanking block assembly, select a model compatible with the valve wiring spec. planned for the future.

DIN rail length specified

—	Standard length	Specify a longer rail than the standard length.
2	2 stations	
16	16 stations	

* Specify the valve stations not exceeding the maximum stations.

SUP/EXH block fitting spec.

—	Straight fitting	
—	With external pilot spec. X, PE port	
L	Elbow fitting (Upward)	
L	With external pilot spec. X, PE port	
B	Elbow fitting (Downward)	
B	With external pilot spec. X, PE port	

* There is no need to enter anything when the SUP/EXH block mounting position "M" is selected.

Pilot spec.

—	Internal pilot
S	Internal pilot/Built-in silencer
R	External pilot
RS	External pilot/Built-in silencer

* There is no need to enter anything when the SUP/EXH block mounting position "M" is selected.

* For built-in silencers, the 3/5(E) ports are plugged.

SUP/EXH block mounting position

U	U side (1 to 10 stations)
D	D side (1 to 10 stations)
B	Both sides (1 to 16 stations)
M*	Special specifications

* Specify the required specifications (including port sizes other than ø8) by means of the manifold specification sheet.

How to Order Valve Manifold Assembly

Ordering example (SS5J3-60S6BD-□)

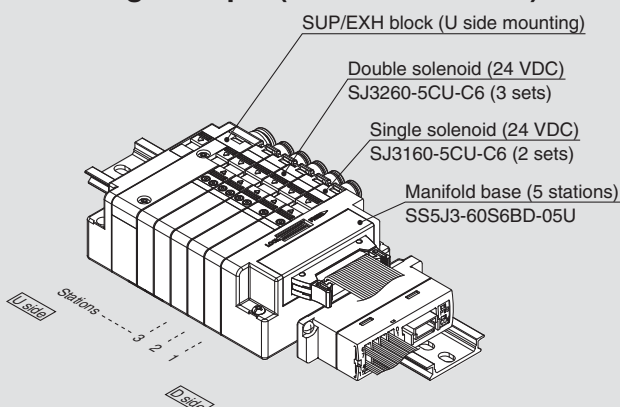

SS5J3-60S6BD-05U ... 1 set (Type 60S6B, 5-station manifold base part no.)
 * **SJ3160-5CU-C6** ... 2 sets (Single solenoid part no.)
 * **SJ3260-5CU-C6** ... 3 sets (Double solenoid part no.)

The asterisk denotes the symbol for assembly. Prefix to the part no. of the solenoid valve, etc.

- The valve arrangement is numbered as the 1st station from D side.
- Indicate the valves to be attached below the manifold part number, in order starting from station 1 as shown in the drawing. In the case of complex arrangement, specify them in the manifold specification sheet.
- Note) When ordering a manifold, specify the part nos. of valves to be mounted together. (An order cannot be placed with only the manifold part no.)

SI Unit Part No.

Symbol	SI unit specifications	SI unit part no.	Page
—	NPN output (Positive common)	EX510-S002C	P.1715 to 1717, Best Pneumatics No.1
N	PNP output (Negative common)	EX510-S102C	

Refer to Reduced Wiring Fieldbus System (Serial Transmission) in Electric Products (CAT.E150) and the Operation Manual for the details of EX510 gateway system serial transmission system. Please download it via our website. <http://www.smc.eu>

How to Order Solenoid Valves

Standard

With switch

Individual wiring
[For plug-in mixed mounting]^(Note)

Note) Refer to pages 61 and 62 for the dedicated non plug-in individual wiring.

SJ 3 1 60 [] [] [] - 5 [] C U [] - C6 - []

SJ 3 1 60 [] [] [] - 5 [] C Z J [] - C6 - []

SJ 3 1 60 [] [] [] - 5 [] M Z [] - C6

SJ 2000 3000

Common Specifications

Construction

Plug-in

Connector Type/
Cable Type

Non plug-in

Individual Wiring

Manifold Options

Made to Order

SJ3A6

Common Specifications/
Construction

Plug-in

Connector Type/
Cable Type

Non plug-in

Individual Wiring

Series

2	SJ2000
3	SJ3000

Back pressure check valve

—	None
K	Built-in

* Back pressure check valve is not applicable for 3 position solenoid valve.

Rated voltage

5	24 VDC
---	--------

Common specifications

—	Positive common
N	Negative common

Pilot spec.

—	Internal pilot
R	External pilot

* External pilot spec. is not applicable for 4 position solenoid dual 3 port valves.

* For the non-polar type, there is no need to select a symbol.

* When equipped with the standard type switch, select common specifications suitable for the SI unit common specifications.

Coil spec.

—	Standard
T	With power saving circuit (Continuous duty type)

* Be sure to select "with power saving circuit" when the solenoid valve will be energised continuously for long period.

Light/surge voltage suppressor

U	With light/surge voltage suppressor (Non-polar type)
Z	With light/surge voltage suppressor (Polar type)

* When the types with power saving circuit, with switches, and individual wiring are used, the non-polar type cannot be selected.

Single solenoid wiring spec.

—	Single wiring
D	Double wiring

* There is no need to enter anything for 2 position double, 3 position and 4 position solenoid valves. Select this when the unused numbers to wiring are set. Refer to page 5 for details.

A, B port size

Straight (Metric size)

C2: ø2 One-touch fitting
C4: ø4 One-touch fitting (SJ3000 only)
C6: ø6 One-touch fitting (SJ3000 only)

(Inch size)

N1: ø1/8" One-touch fitting
N3: ø5/32" One-touch fitting
N7: ø1/4" One-touch fitting (SJ3000 only)

M3: M3 x 0.5 (SJ2000 only)
M5: M5 x 0.8 (SJ3000 only)

Elbow fitting assembly (Upward entry) (Metric size)

L2: ø2 elbow fitting assembly
L4: ø4 elbow fitting assembly
L6: ø6 elbow fitting assembly (SJ3000 only)

(Inch size)

LN1: ø1/8" elbow fitting assembly
LN3: ø5/32" elbow fitting assembly
LN7: ø1/4" elbow fitting assembly (SJ3000 only)

Elbow fitting assembly (Downward entry) (Metric size)

B2: ø2 elbow fitting assembly
B4: ø4 elbow fitting assembly
B6: ø6 elbow fitting assembly (SJ3000 only)

(Inch size)

BN1: ø1/8" elbow fitting assembly
BN3: ø5/32" elbow fitting assembly
BN7: ø1/4" elbow fitting assembly (SJ3000 only)

Connector entry

C: Dedicated for centralised wiring

M: Individual wiring, With lead wire Length 300 mm

MN: Individual wiring, Without lead wire

MO: Individual wiring, Without connector

* Connector entries with the symbol "M□" can not use the switch signal from the common wiring on the manifold. For details, refer to "Connector Wiring Diagram" on page 5.

* When ordering a connector assembly separately, refer to pages 101 and 102.

With switch

Manual override

—: Non-locking push type

D: Push-turn locking slotted type

F: Slide locking type

Protective class class III (Mark: ⚡)

Series SJ2000/3000

Dimensions: Series SJ2000 for EX510 Gateway System Serial Transmission System

SS5J2-60S6B □ D- Stations U- □

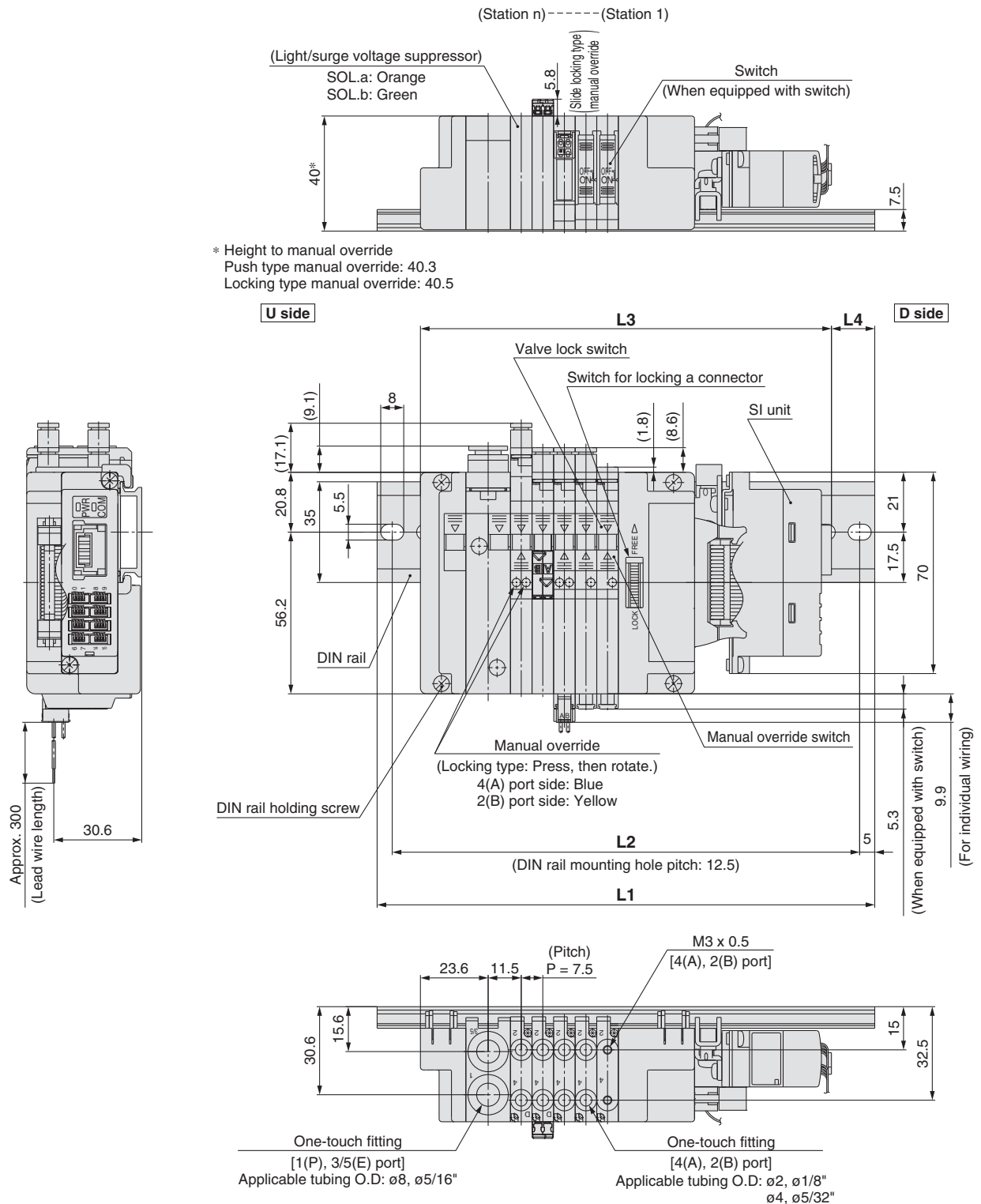

Note) Refer to page 43 for the external pilot specifications, page 31 for the dimensions of the manifold with elbow fittings, and pages 1696 to 1724 of Best Pneumatics No.1 for the details of SI unit.

L: Dimensions

n: Stations

L \ n	1	2	3	4	5	6	7	8	9	10
L1	148	148	160.5	160.5	173	185.5	185.5	198	198	210.5
L2	137.5	137.5	150	150	162.5	175	175	187.5	187.5	200
L3	112.9	120.4	127.9	135.4	142.9	150.4	157.9	165.4	172.9	180.4
L4	17.5	14	16.5	12.5	15	17.5	14	16.5	12.5	15

Dimensions: Series SJ2000 for EX510 Gateway System Serial Transmission System

SS5J2-60S6B □ D- Stations B- □

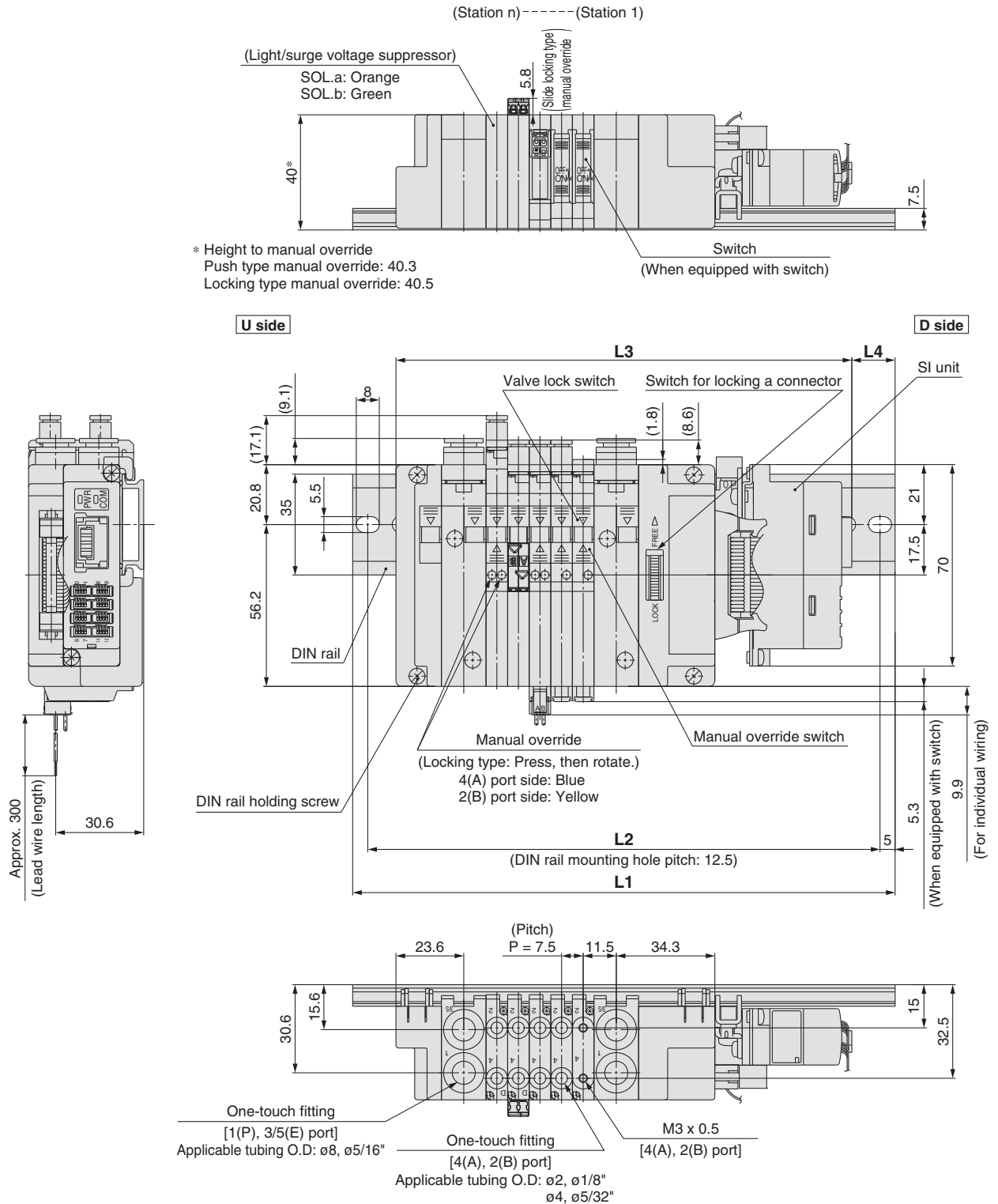

Note) Refer to page 44 for the external pilot specifications, page 31 for the dimensions of the manifold with elbow fittings, and pages 1696 to 1724 of Best Pneumatics No.1 for the details of SI unit.

L: Dimensions

		n: Stations															
L \ n	1	2	3	4	5	6	7	8	9	10	11	12	13	14	15	16	
L1	160.5	160.5	173	185.5	185.5	198	198	210.5	223	223	235.5	248	248	260.5	260.5	273	
L2	150	150	162.5	175	175	187.5	187.5	200	212.5	212.5	225	237.5	237.5	250	250	262.5	
L3	128.4	135.9	143.4	150.9	158.4	165.9	173.4	180.9	188.4	195.9	203.4	210.9	218.4	225.9	233.4	240.9	
L4	16	12.5	15	17.5	13.5	16	12.5	15	17.5	13.5	16	18.5	15	17.5	13.5	16	

Series SJ2000/3000

Dimensions: Series SJ3000 for EX510 Gateway System Serial Transmission System

SS5J3-60S6B □ D- Stations U- □

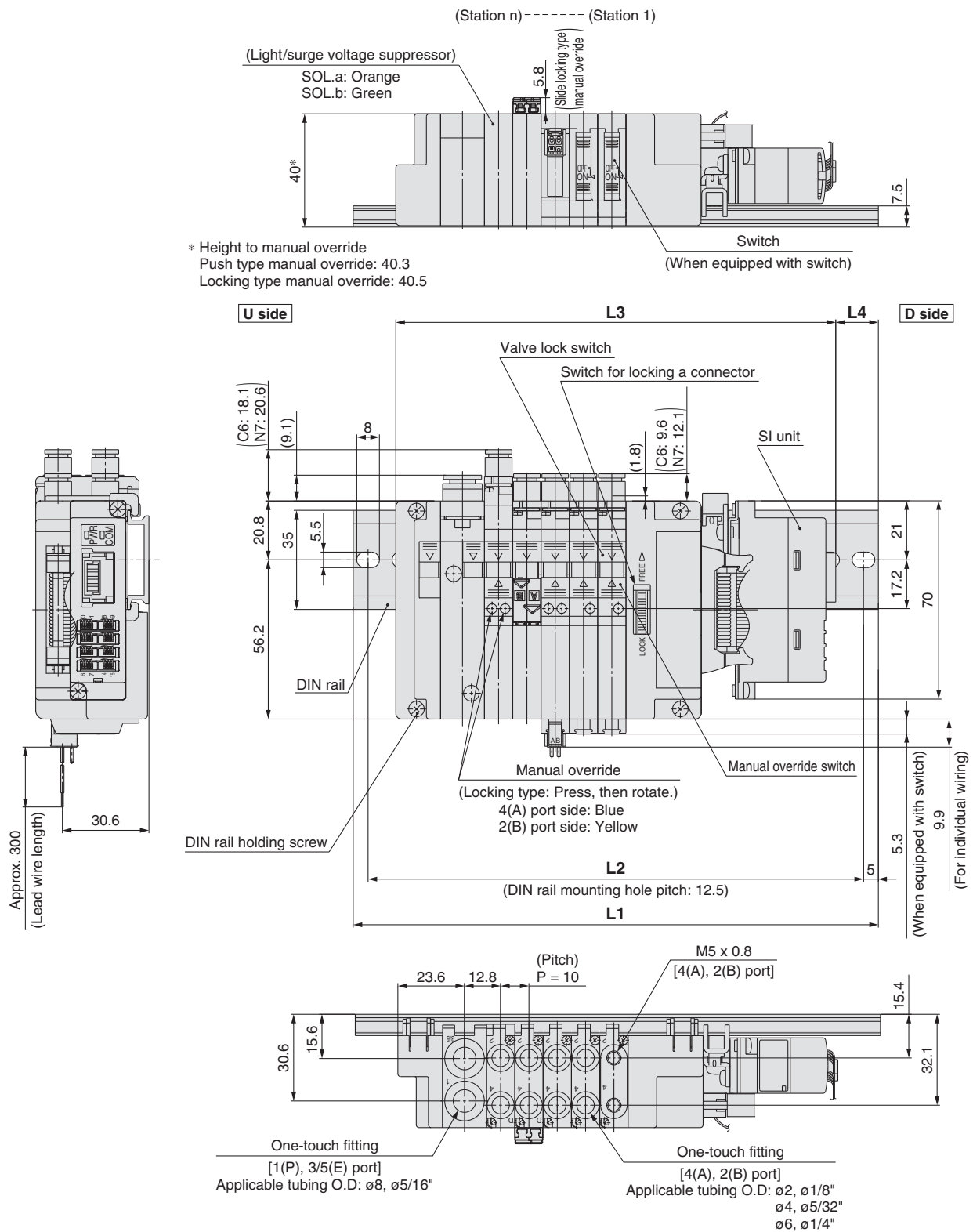

Note) Refer to page 45 for the external pilot specifications, page 32 for the dimensions of the manifold with elbow fittings, and pages 1696 to 1724 of Best Pneumatics No.1 for the details of SI unit.

L: Dimensions

n: Stations

L \ n	1	2	3	4	5	6	7	8	9	10
L1	148	160.5	160.5	173	185.5	198	210.5	210.5	223	235.5
L2	137.5	150	150	162.5	175	187.5	200	200	212.5	225
L3	115.4	125.4	135.4	145.4	155.4	165.4	175.4	185.4	195.4	205.4
L4	16.5	17.5	12.5	14	15	16.5	17.5	12.5	14	15

Dimensions: Series SJ3000 for EX510 Gateway System Serial Transmission System

SS5J3-60S6B □ D- Stations B- □

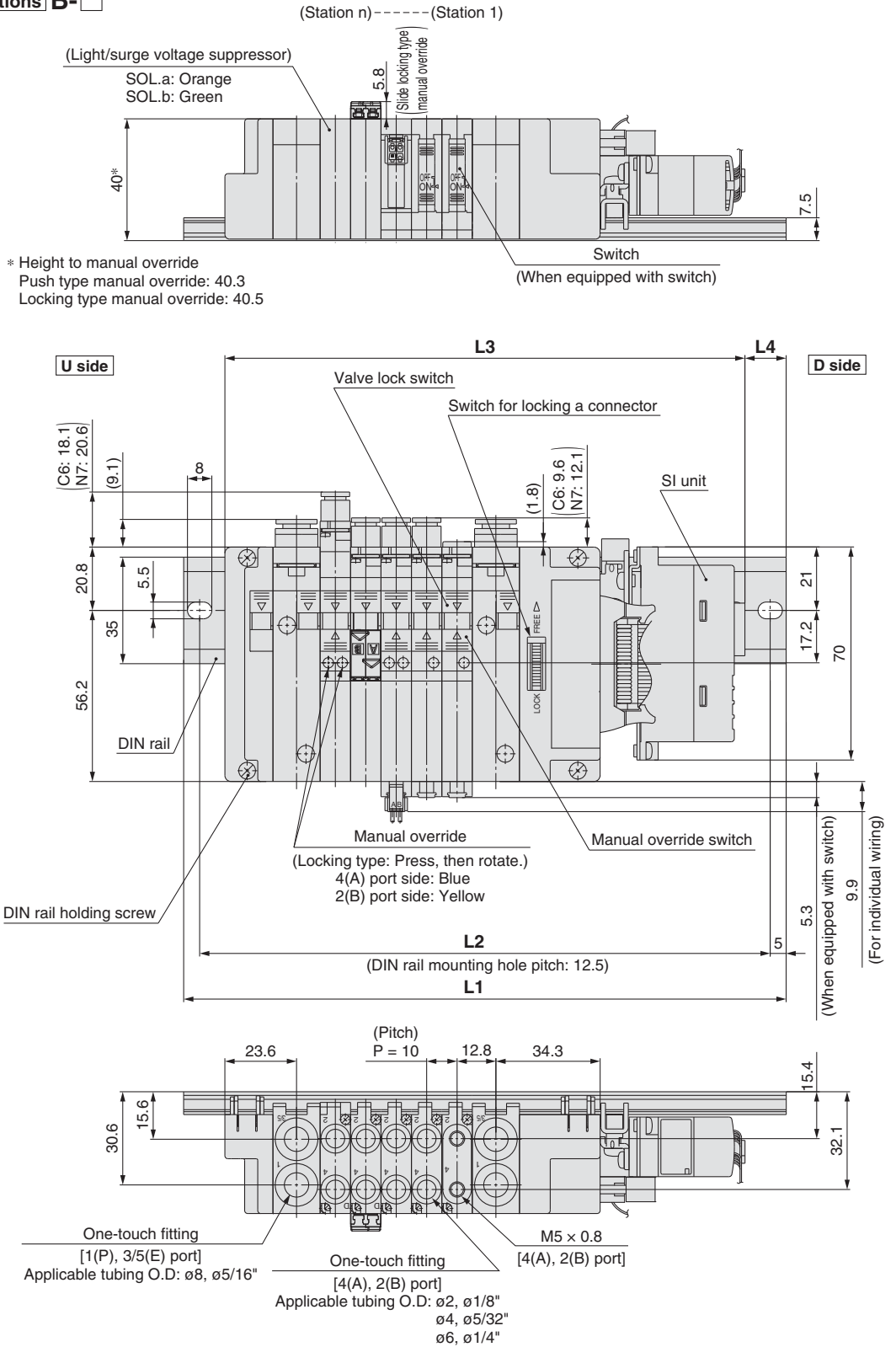

Note) Refer to page 46 for the external pilot specifications, page 32 for the dimensions of the manifold with elbow fittings, and pages 1696 to 1724 of Best Pneumatics No.1 for the details of SI unit.

L: Dimensions

		n: Stations															
L \ n	1	2	3	4	5	6	7	8	9	10	11	12	13	14	15	16	
L1	160.5	173	185.5	185.5	198	210.5	223	235.5	248	248	260.5	273	285.5	298	298	310.5	
L2	150	162.5	175	175	187.5	200	212.5	225	237.5	237.5	250	262.5	275	287.5	287.5	300	
L3	130.9	140.9	150.9	160.9	170.9	180.9	190.9	200.9	210.9	220.9	230.9	240.9	250.9	260.9	260.9	280.9	
L4	15	16	17.5	12.5	13.5	15	16	17.5	18.5	13.5	15	16	17.5	18.5	18.5	15	

Series SJ2000/3000

Dimensions: SJ2000/3000 Mixed Manifold for EX510 Gateway System Serial Transmission System

SS5J3-M60S6B D- Stations U-

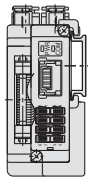

L dimension: Formula, L1 to L4
 $L3 = 7.5 \times n1 + 10 \times n2 + 105.4$
 $M = (L3 + 4) / 12.5 + 1$
 Remove all numbers after the decimal.
 $L1 = M \times 12.5 + 23$
 $L2 = L1 - 10.5$
 $L4 = (L1 - L3) / 2 - 2$

n1: Quantity of SJ2000
 n2: Quantity of SJ3000

* The dimensions of L1 to L4 for SS5J3-M60S6B D- Stations D are the same as those of SS5J3-M60S6B D- Stations U.

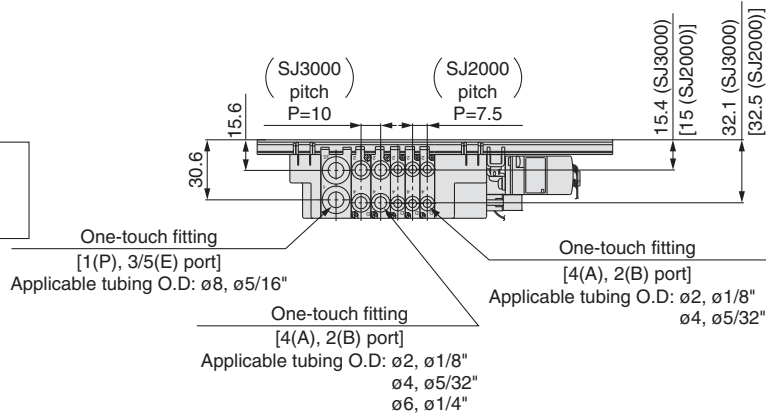
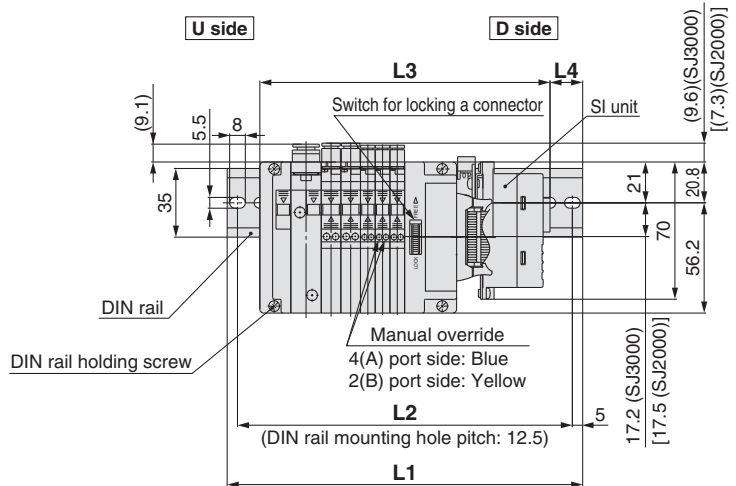

SS5J3-M60S6B D- Stations B-

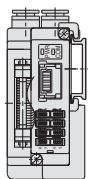

L dimension: Formula, L1 to L4
 $L3 = 7.5 \times n1 + 10 \times n2 + 120.9$
 $M = (L3 + 4) / 12.5 + 1$
 Remove all numbers after the decimal.
 $L1 = M \times 12.5 + 23$
 $L2 = L1 - 10.5$
 $L4 = (L1 - L3) / 2 - 2$

n1: Quantity of SJ2000
 n2: Quantity of SJ3000

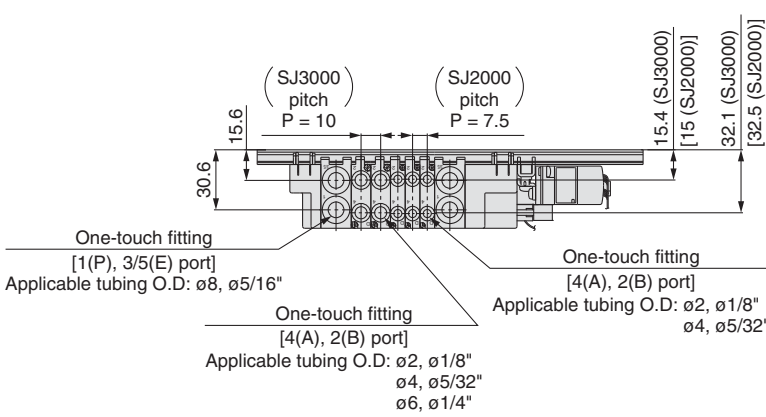
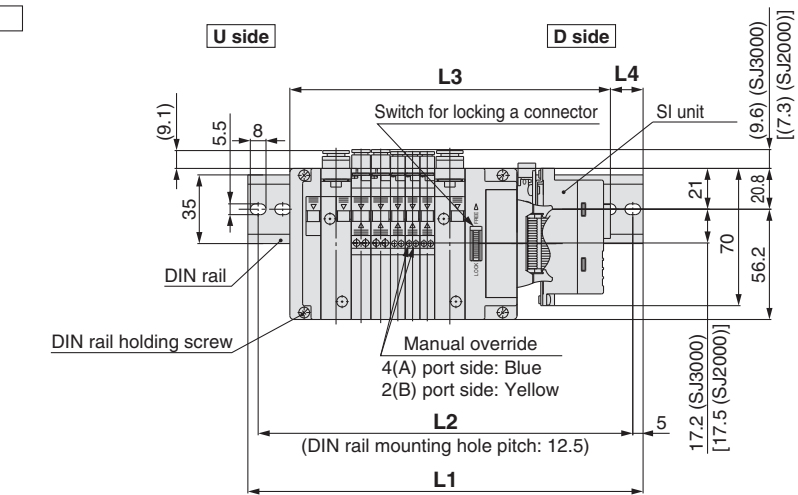

Manifold Exploded View 1

Connector Type

Type 60P (Flat ribbon cable) manifold

Type 60S (Plug-in, EX180 Integrated type (for output) serial transmission system) manifold

Type 60G (Plug-in, PC wiring with power supply terminal) manifold

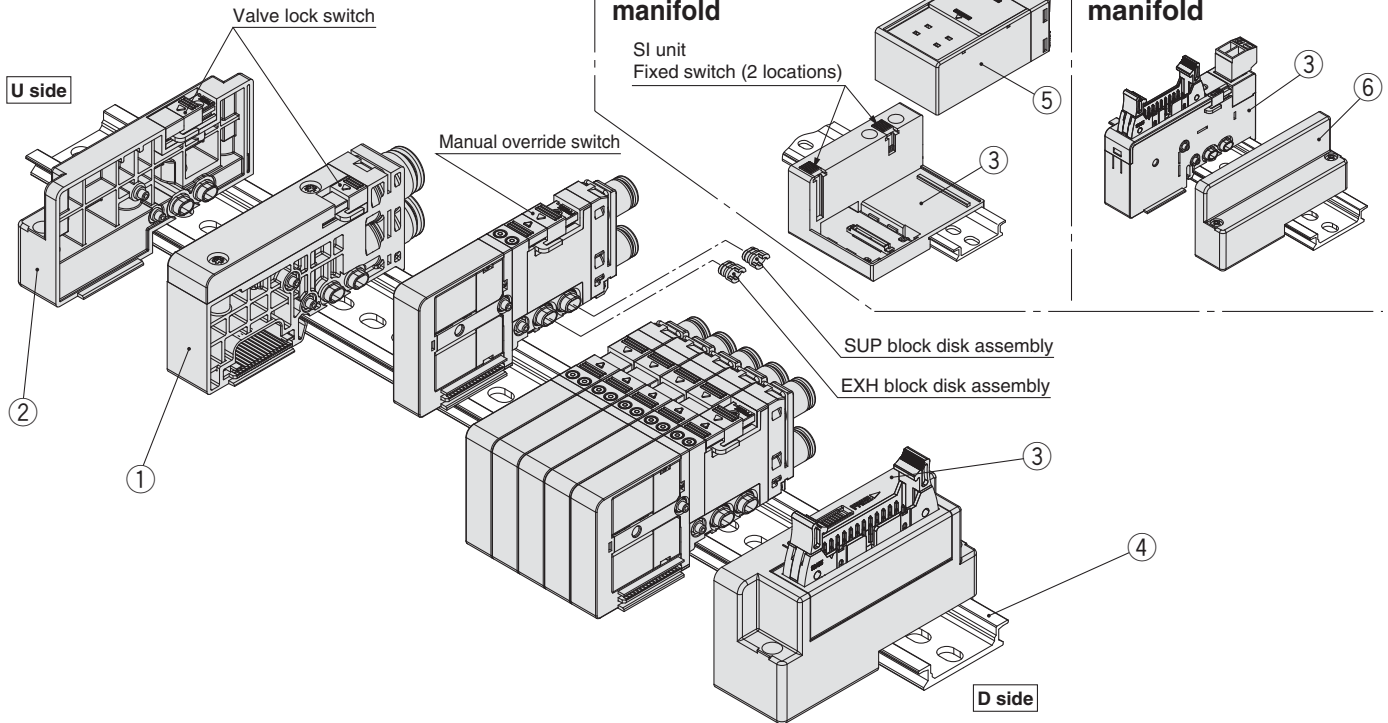

Component Parts/Plug-in (Connector Type)

No.	Description	Part no.	Note
1	Internal pilot	SJ3000-50-1A-□□	(Metric size) C6: With ø6 One-touch fitting (straight) C8: With ø8 One-touch fitting (straight) L6: With ø6 One-touch fitting (elbow upward entry) L8: With ø8 One-touch fitting (elbow upward entry) B6: With ø6 One-touch fitting (elbow downward entry) B8: With ø8 One-touch fitting (elbow downward entry)
	Internal pilot/Built-in silencer	SJ3000-50-1AS-□□	
	External pilot	SJ3000-50-1AR-□□ (X, PE port: Metric size ø4 Inch size ø5/32")	
	External pilot/Built-in silencer	SJ3000-50-1ARS-□□ (X port: Metric size ø4 Inch size ø5/32")	
	For different pressures, internal pilot ^{Note 1)}	SJ3000-50-3A-□□	
	For different pressures, internal pilot/Built-in silencer ^{Note 1)}	SJ3000-50-3AS-□□	
2	End block assembly	SJ3000-53-1A	For U side
3	Connector block assembly	SJ3000-42-□A-□ SJ3000-76-2A-05	Refer to the connector block assembly part no. shown below.
4	DIN rail	VZ1000-11-1-□	Refer to page 71.
5	SI unit	EX180-□□	Refer to the SI unit part numbers on page 41.
6	End block assembly	SJ3000-53-2A	For D side

Note 1) The valves cannot be operated only with the SUP/EXH block assembly for different pressure, select them in combination with the SUP/EXH block assembly for internal/external pilot.

Note 2) Refer to page 69 about the SUP/EXH block disk assembly and method of handling of parts at different pressures.

Connector Block Assembly Part No.

Connector specifications	Mounting position	Part no.	Note
For D-sub connector (Locking bracket: Metric size thread)	D side	SJ3000-42-1A-□	□: 1 (Connector upward) □: 2 (Connector lateral)
For D-sub connector (Locking bracket: Unified thread)		SJ3000-42-1AU-□	
For flat ribbon cable 26 pins		SJ3000-42-2A-□	
For flat ribbon cable 20 pins		SJ3000-42-3A-□	
For flat ribbon cable 10 pins		SJ3000-42-4A-□	
For PC wiring 20 pins		SJ3000-42-6A-□	
For EX180 serial wiring ^{Note)}		SJ3000-42-20A	
For EX510 serial wiring ^{Note)}		SJ3000-42-3A-2	
For PC wiring 20 pins with power supply terminal		SJ3000-76-2A-05	

Note) SI unit is not included.

Connector Block Assembly with SI Unit

Connector block assembly with EX180 serial wiring	D side	SJ3000-42-20A-□□	For details on □□ portion, refer to the SI unit part no. on page 41. Example: SJ3000-42-20A-V ₂ (CC-LINK compliant, T-branch type)
---	--------	------------------	---

SJ
2000
3000

Common
Specifications

Construction

Plug-in

Connector Type/
Cable Type

Non plug-in

Individual
Wiring

Manifold
Options

Made to
Order

SJ3A6

Common Specifications/
Construction

Plug-in

Connector Type/
Cable Type

Non plug-in

Individual
Wiring

Series SJ2000/3000

Manifold Exploded View 2

Cable Type

Type 60LP (Flat ribbon cable)
manifold

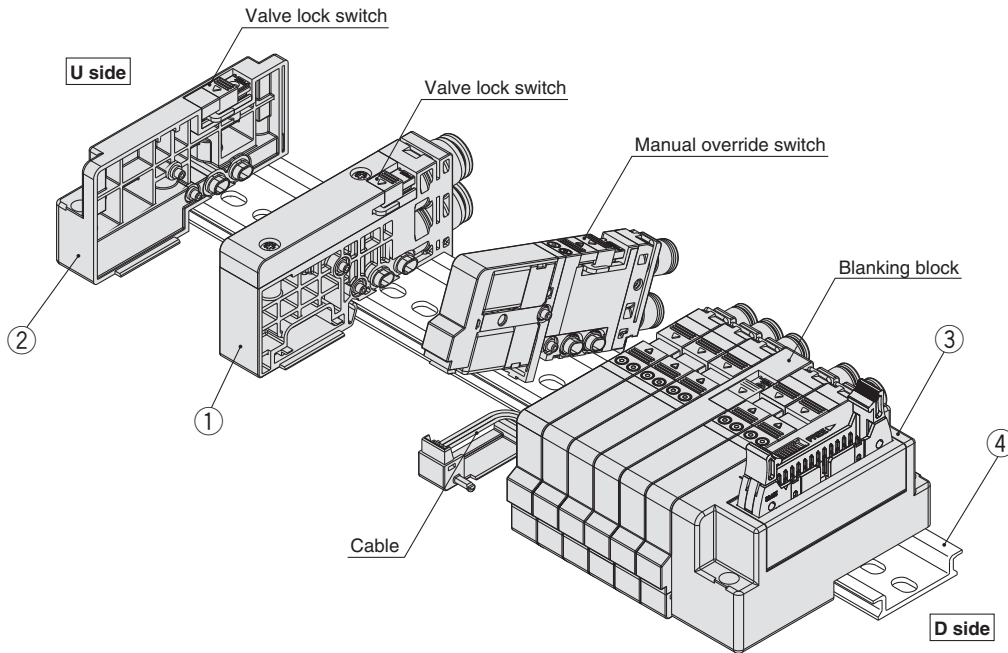

Component Parts/Plug-in (Cable Type)

No.	Description	Part no.	Note
1	Internal pilot	SJ3000-50-5A-□□	(Metric size) C6: With ø6 One-touch fitting (straight) C8: With ø8 One-touch fitting (straight) L6: With ø6 One-touch fitting (elbow upward entry) L8: With ø8 One-touch fitting (elbow upward entry) B6: With ø6 One-touch fitting (elbow downward entry) B8: With ø8 One-touch fitting (elbow downward entry) (Inch size) N7: With 1/4" One-touch fitting (straight) N9: With 5/16" One-touch fitting (straight)
	Internal pilot/Built-in silencer	SJ3000-50-5AS-□□	
	External pilot	SJ3000-50-5AR-□□ (X, PE port: Metric size ø4 Inch size ø5/32")	
	External pilot/Built-in silencer	SJ3000-50-5ARS-□□ (X port: Metric size ø4 Inch size ø5/32")	
	For different pressures, internal pilot ^{Note 1)}	SJ3000-50-6A-□□	
	For different pressures, internal pilot/Built-in silencer ^{Note 1)}	SJ3000-50-6AS-□□	
2	End block assembly	SJ3000-53-1A	For U side
3	Connector block assembly	SJ3000-42-□A-□	Refer to the connector block assembly part no. shown below.
4	DIN rail	VZ1000-11-1-□	Refer to page 71.

Note 1) The valves cannot be operated only with the SUP/EXH block assembly for different pressure, select them in combination with the SUP/EXH block assembly for internal/external pilot.

Note 2) Refer to page 69 about the SUP/EXH block disk assembly and method of handling of parts at different pressures.

●Connector Block Assembly

SJ3000-42-□ A □ - □ - □ 05

Connector type

7	For D-sub connector	Series SJ3000
8	For flat ribbon cable 26 pins	
9	For flat ribbon cable 20 pins	
10	For flat ribbon cable 10 pins	
11	For D-sub connector	Series SJ2000
12	For flat ribbon cable 26 pins	
13	For flat ribbon cable 20 pins	
14	For flat ribbon cable 10 pins	

* All connector block assembly mounting positions become the D side.

* The connector block assembly includes the cables necessary for the number of stations.

Locking bracket

—	Metric size thread
U	Unified thread

* D-sub connector only.

Valve stations

02 to 10	For D-sub connector	All double wiring
02 to 20		All single wiring
02 to 10	For flat ribbon cable 26 pins	All double wiring
02 to 20		All single wiring
02 to 09	For flat ribbon cable 20 pins	All double wiring
02 to 18		All single wiring
02 to 04	For flat ribbon cable 10 pins	All double wiring
02 to 08		All single wiring

Wiring

—	All double wiring
S	All single wiring

Connector entry direction

1	Upward
2	Lateral

Connector Type

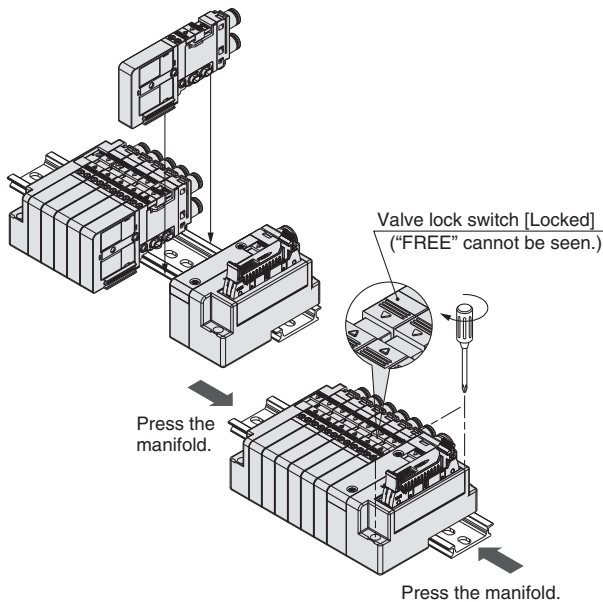
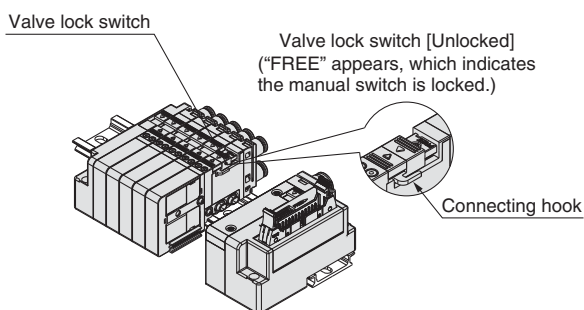
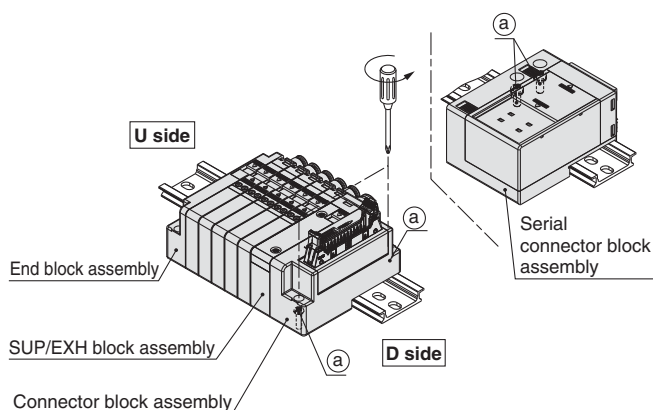

1 Loosen threads (a), which are fixed onto the DIN rail (two locations on one side).

2 In the direction of the coil, slide the valve where the station is desired to add and the valve lock switch on each block.

If blocks are removed without completely releasing the valve lock switch, the connection hook of that switch could be damaged or deformed.

3 Install an additional valve or an SUP/EXH block assembly block on the DIN rail.

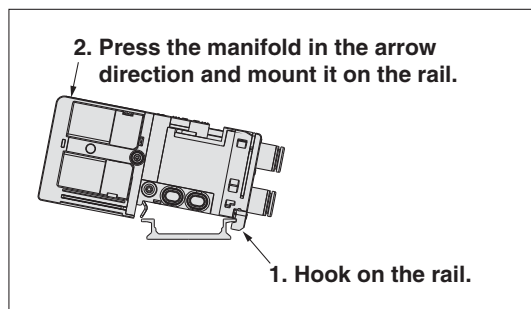

A manifold equipped with a valve or a block assembly can be mounted on the DIN rail. However, a serial connector block assembly cannot be mounted on the DIN rail when it is connected with another block; the serial connector block must be mounted separately.

4 Press the valves and block assemblies to each other for connection. Press the valve lock switch in the cylinder port direction until it does not go any further. Fasten threads (a) onto the DIN rail.

After fixing the connector block assembly, fasten the threads onto the end block assembly while holding it lightly by hand. This is necessary to improve sealing.

Caution (D-sub, Connector block assembly for flat ribbon cable, End block assembly M3: 0.6 N·m
Connector block assembly for EX180 serial wiring M4: 1.4 N·m
Mounting bracket for EX510 serial wiring M4: 0.6 N·m)

Caution

- When increasing the number of stations from 10 or below to 11 or above, increase the number of SUP/EXH block assemblies as well.
- Be sure to turn off the power and stop the supply of air before disassembly. Furthermore, since air may remain inside the actuator, piping and manifold, confirm that the air is completely exhausted before performing any work.
- After assembly and disassembly, air leakage could occur if blocks are not well connected or a thread is not tightly fastened onto the end block assembly. Before supplying air, make sure that no gaps exist in between blocks and that the valve and block are tightly fastened onto the DIN rail. Also, make sure that air is not leaking before use.
- For the SJ3A6 series manifold with vacuum release valve with restrictor, there is no valve lock switch for connecting, so when mounting, tighten the screws after checking that there are no gaps between valves.

How to Increase Manifold Stations 2

Cable Type

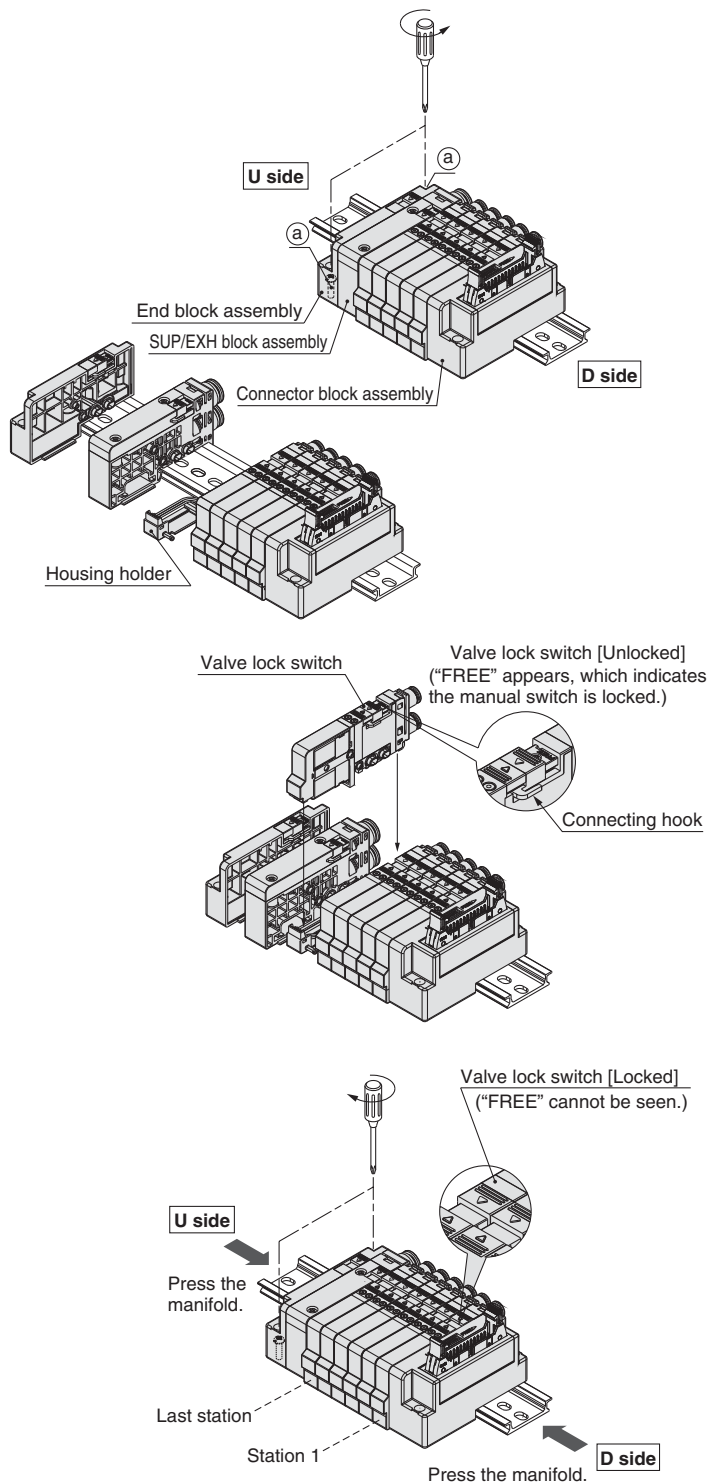

⚠ Caution

To increase a manifold station, a housing holder (refer to the table below) is required in addition to the solenoid valve.

For the manifold with less than the maximum stations, spare housing (for one station) for adding the manifold station is stored in the housing holder of the last station or the SUP/EXH block assembly. To increase a manifold station, follow the steps below to disassemble and reassemble the manifold.

Series	Housing holder part no.	Material	Note
SJ2000	SJ2000-86-1	Resin	White
SJ3000	SJ3000-86-1		

1 Loosen threads (a), which are fixed onto the DIN rail (two locations).

[Note: To replace the DIN rail, also loosen the screws (2 locations) on the connector block assembly.]

2 Slide the valve lock switch on each block toward the coil, and then remove the end block assembly and SUP/EXH block assembly.

3 Take out the stored housing for adding the manifold station and assemble it to a newly added housing holder. Insert this housing holder next to the existing housing holder.

How to mount the housing

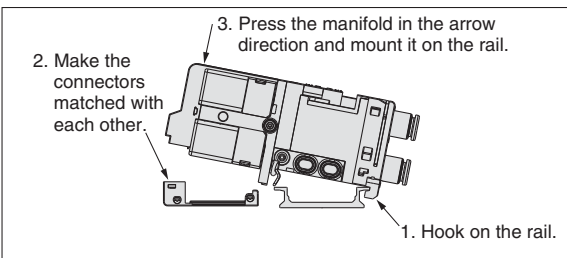
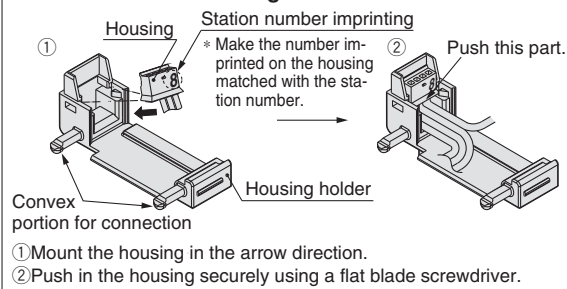

4 Press the valves and block assemblies to each other for connection. Press the valve lock switch in the cylinder port direction until it does not go any further. Fasten threads (a) onto the DIN rail. Connect the added valve and SUP/EXH block, and then fasten the DIN rail fixing screws on the end block on the U side.

(After fixing the connector block assembly, fasten the threads onto the end block assembly while holding it lightly by hand. This is necessary to improve sealing.)

⚠ Caution D-sub, Connector block assembly for flat ribbon cable, End block assembly M3: 0.6 N-m

⚠ Caution

- When increasing the number of stations from 10 or below to 11 or above, increase the number of SUP/EXH block assemblies as well. Add the valve to the U side of the last station, and then add the SUP/EXH block assembly to its U side. The SUP/EXH block cannot be added to a position adjacent to the connector block assembly or an intermediate position.
- Be sure to turn off the power and stop the supply of air before disassembly. Furthermore, since air may remain inside the actuator, piping and manifold, confirm that the air is completely exhausted before performing any work.
- After assembly and disassembly, air leakage could occur if blocks are not well connected or a thread is not tightly fastened onto the end block assembly. Before supplying air, make sure that no gaps exist in between blocks and that the valve and block are tightly fastened onto the DIN rail. Also, make sure that air is not leaking before use.
- For the SJ3A6 series manifold with vacuum release valve with restrictor, there is no valve lock switch for connecting, so when mounting, tighten the screws after checking that there are no gaps between valves.

Non Plug-in Individual Wiring Manifold

Series *SJ2000/3000*

P.61 Individual Wiring

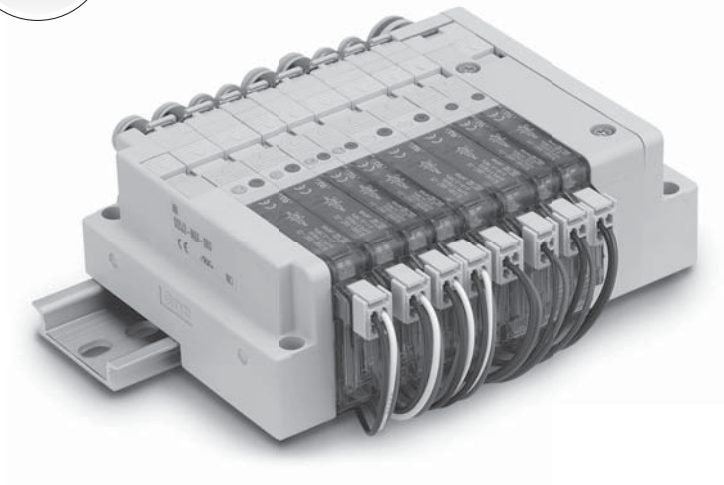

SJ
2000
3000

Common
Specifications

Construction

Connector Type/
Cable Type | **Plug-in**

Individual
Wiring | **Non plug-in**

Manifold
Options

Made to
Order

SJ3A6

Common Specifications/
Construction

Connector Type/
Cable Type | **Plug-in**

Individual
Wiring | **Non plug-in**

Non plug-in Individual Wiring



Series SJ2000/3000

An order cannot be placed with only the manifold part no. Be sure to order solenoid valves for mounting at the same time while referring to the ordering example.

How to Order

● Individual wiring manifold

SS5J 3 - **60** - **05 U** □ □ □

Series

2	SJ2000
3	SJ3000 (SJ2000/3000 mixed)

Mixed mounting type

—	Standard ^{Note 1)}
M	Mixed mounting ^{Note 2)}

Note 1) There is no need to enter anything when you operate either the SJ2000 or SJ3000 series alone.
 Note 2) Enter "M" when the SJ2000 or SJ3000 series will be mounted on the same manifold base together.

Valve stations

Symbol	Stations
01	1 station
⋮	⋮
20	20 stations

DIN rail length specified

—	Standard length	
2	2 stations	Specify a longer rail than the
⋮	⋮	standard length.
20	20 stations	

* Specify the valve stations not exceeding the maximum stations.

SUP/EXH block fitting spec.

—	Straight fitting With external pilot spec. X, PE port	
L	Elbow fitting (Upward) With external pilot spec. X, PE port	
B	Elbow fitting (Downward) With external pilot spec. X, PE port	

* There is no need to enter anything when the SUP/EXH block mounting position "M" is selected.

Pilot spec.

—	Internal pilot
S	Internal pilot/Built-in silencer
R	External pilot
RS	External pilot/Built-in silencer

* There is no need to enter anything when the SUP/EXH block mounting position "M" is selected.
 * For built-in silencers, the 3/5(E) ports are plugged.

SUP/EXH block mounting position

U	U side (1 to 10 stations)
D	D side (1 to 10 stations)
B	Both sides (1 to 20 stations)
M*	Special specifications

* Specify the required specifications (including port sizes other than ø8) by means of the manifold specification sheet.

How to Order Manifold Assembly

Ordering example (SS5J3-60-□)

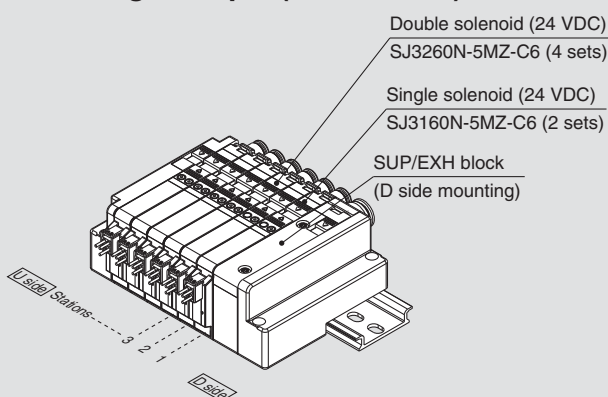

SS5J3-60-06D 1 set (Manifold part no.)
 * **SJ3160N-5MZ-C6** ... 2 sets (Single solenoid part no.)
 * **SJ3260N-5MZ-C6** ... 4 sets (Double solenoid part no.)

→ The asterisk denotes the symbol for assembly.
 Prefix to the part no. of the solenoid valve, etc.

- The valve arrangement is numbered as the 1st station from D side.
- Indicate the valves to be attached below the manifold part number, in order starting from station 1 as shown in the drawing. In the case of complex arrangement, specify them in the manifold specification sheet.

How to Order Solenoid Valves

SJ 3 1 60 [] [] [] N - 5 [] M Z [] - C6

Series

2	SJ2000
3	SJ3000

Type of actuation

1	2 position single solenoid
2	2 position double solenoid
3	3 position closed centre
4	3 position exhaust centre
5	3 position pressure centre
A	Dual 3 port valve: N.C./N.C.
B	Dual 3 port valve: N.O./N.O.
C	Dual 3 port valve: N.C./N.O.

* Refer to pages 6 through to 13 for the Symbol.

Pilot spec.

—	Internal pilot
R	External pilot

* External pilot spec. is not applicable for 4 position dual 3 port valves.

Back pressure check valve

—	None
K	Built-in

* Back pressure check valve is not applicable for 3 position solenoid valve.

Coil spec.

—	Standard
T	With power saving circuit (Continuous duty type)

* Be sure to select "with power saving circuit" when the solenoid valve will be energised continuously for long period.

Rated voltage

5	24 VDC
6	12 VDC

Common specifications

—	Positive common
N	Negative common

A, B port size

Straight (Metric size)
C2: ø2 One-touch fitting
C4: ø4 One-touch fitting
C6: ø6 One-touch fitting (SJ3000 only)
 (Inch size)
N1: ø1/8" One-touch fitting
N3: ø5/32" One-touch fitting
N7: ø1/4" One-touch fitting (SJ3000 only)

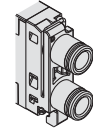

M3: M3 x 0.5 (SJ2000 only)
M5: M5 x 0.8 (SJ3000 only)

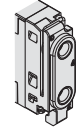

Elbow fitting assembly (Upward entry) (Metric size)
L2: ø2 elbow fitting assembly
L4: ø4 elbow fitting assembly
L6: ø6 elbow fitting assembly (SJ3000 only)
 (Inch size)
LN1: ø1/8" elbow fitting assembly
LN3: ø5/32" elbow fitting assembly
LN7: ø1/4" elbow fitting assembly (SJ3000 only)

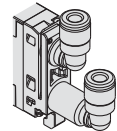

Elbow fitting assembly (Downward entry) (Metric size)
B2: ø2 elbow fitting assembly
B4: ø4 elbow fitting assembly
B6: ø6 elbow fitting assembly (SJ3000 only)
 (Inch size)
BN1: ø1/8" elbow fitting assembly
BN3: ø5/32" elbow fitting assembly
BN7: ø1/4" elbow fitting assembly (SJ3000 only)

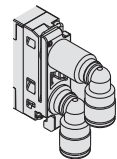

Non-plug-in

With light/surge voltage suppressor

Manual override

—: Non-locking push type

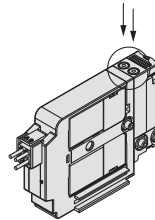

D: Push-turn locking slotted type

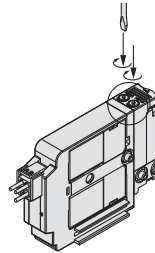

F: Slide locking type

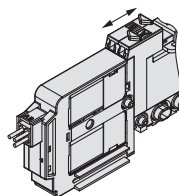

Connector entry

M: Individual wiring, With lead wire Length 300 mm

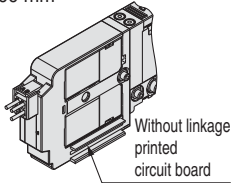

MN: Individual wiring, Without lead wire (With connector, socket)

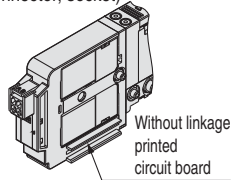

MO: Individual wiring, Without connector

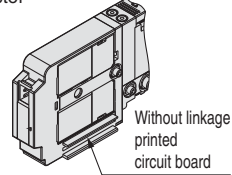

* When ordering a connector assembly separately, refer to pages 101 and 102.

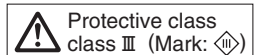

SJ 2000 3000

Common Specifications

Construction

Plug-in

Connector Type/ Cable Type

Non plug-in

Individual Wiring

Manifold Options

Made to Order

SJ3A6

Common Specifications/ Construction

Plug-in

Connector Type/ Cable Type

Non plug-in

Individual Wiring

Series SJ2000/3000

Dimensions

SS5J2-60- Stations U (S, R, RS)

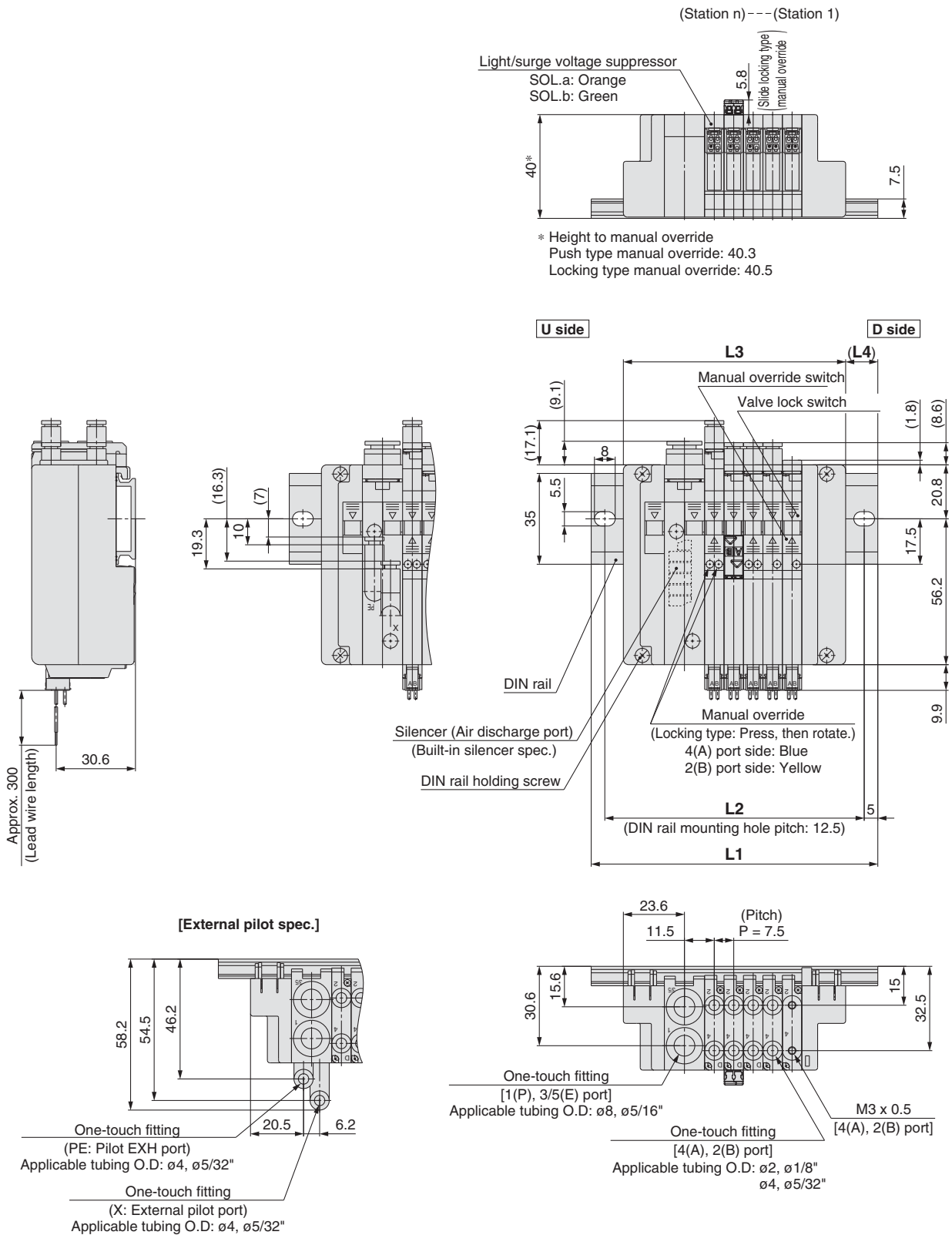

L: Dimensions

n: Stations

L \ n	1	2	3	4	5	6	7	8	9	10
L1	85.5	98	98	110.5	110.5	123	135.5	135.5	148	148
L2	75	87.5	87.5	100	100	112.5	125	125	137.5	137.5
L3	55.7	63.2	70.7	78.2	85.7	93.2	100.7	108.2	115.7	123.2
L4	15	17.5	13.5	16	12.5	15	17.5	13.5	16	12.5

Note) For manifold dimensions including elbow fitting, refer to page 31.

Dimensions

SS5J2-60- Stations B (S, R, RS)

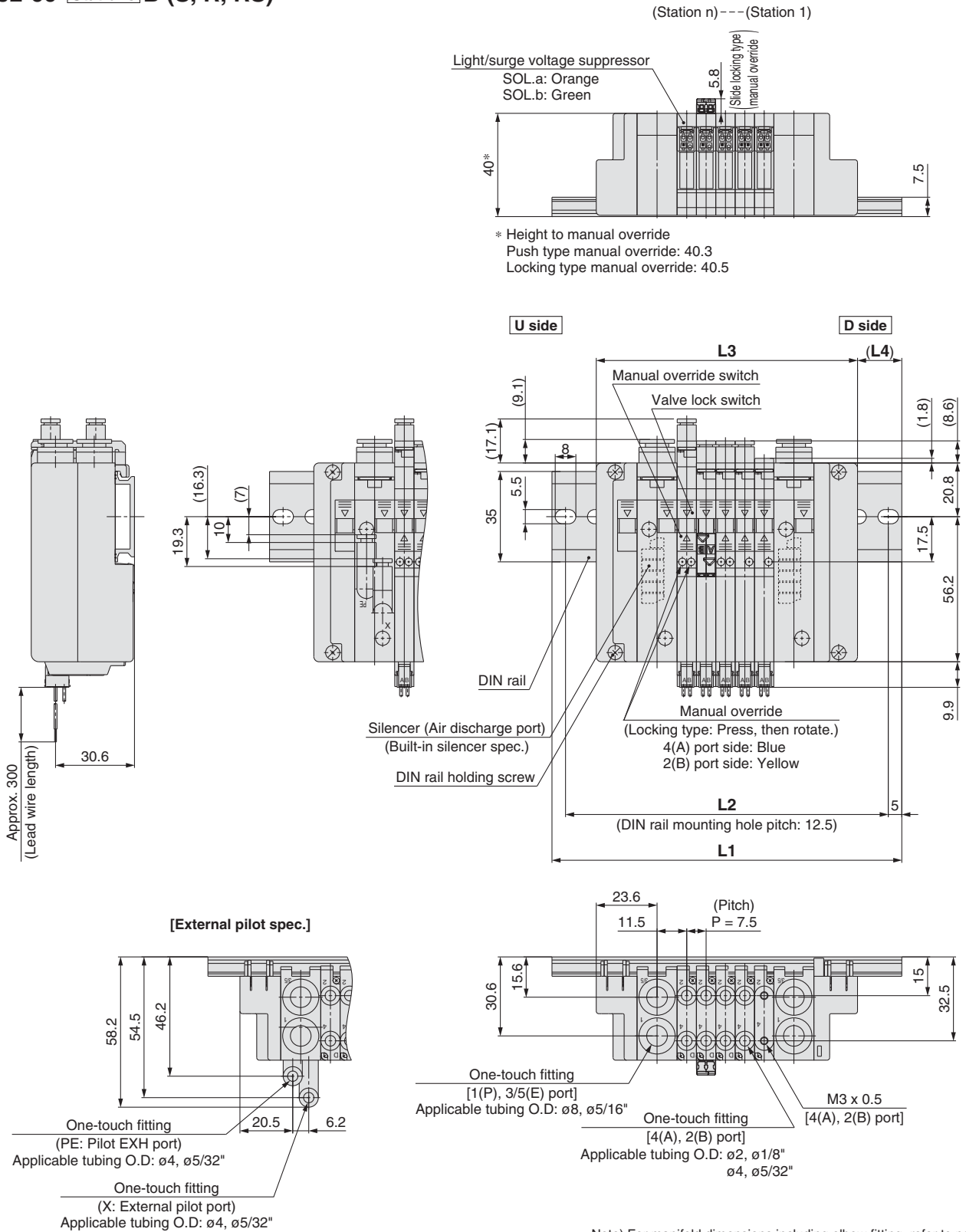

L: Dimensions

		n: Stations																		
L \ n	1	2	3	4	5	6	7	8	9	10	11	12	13	14	15	16	17	18	19	20
L1	98	110.5	110.5	123	135.5	135.5	148	148	160.5	173	173	185.5	185.5	198	210.5	210.5	223	223	235.5	248
L2	87.5	100	100	112.5	125	125	137.5	137.5	150	162.5	162.5	175	175	187.5	200	200	212.5	212.5	225	237.5
L3	71.2	78.7	86.2	93.7	101.2	108.7	116.2	123.7	131.2	138.7	146.2	153.7	161.2	168.7	176.2	183.7	191.2	198.7	206.2	213.7
L4	13.5	16	12	14.5	17	13.5	16	12	14.5	17	13.5	16	12	14.5	17	13.5	16	12	14.5	17

Series SJ2000/3000

Dimensions

SS5J3-60- Stations U (S, R, RS)

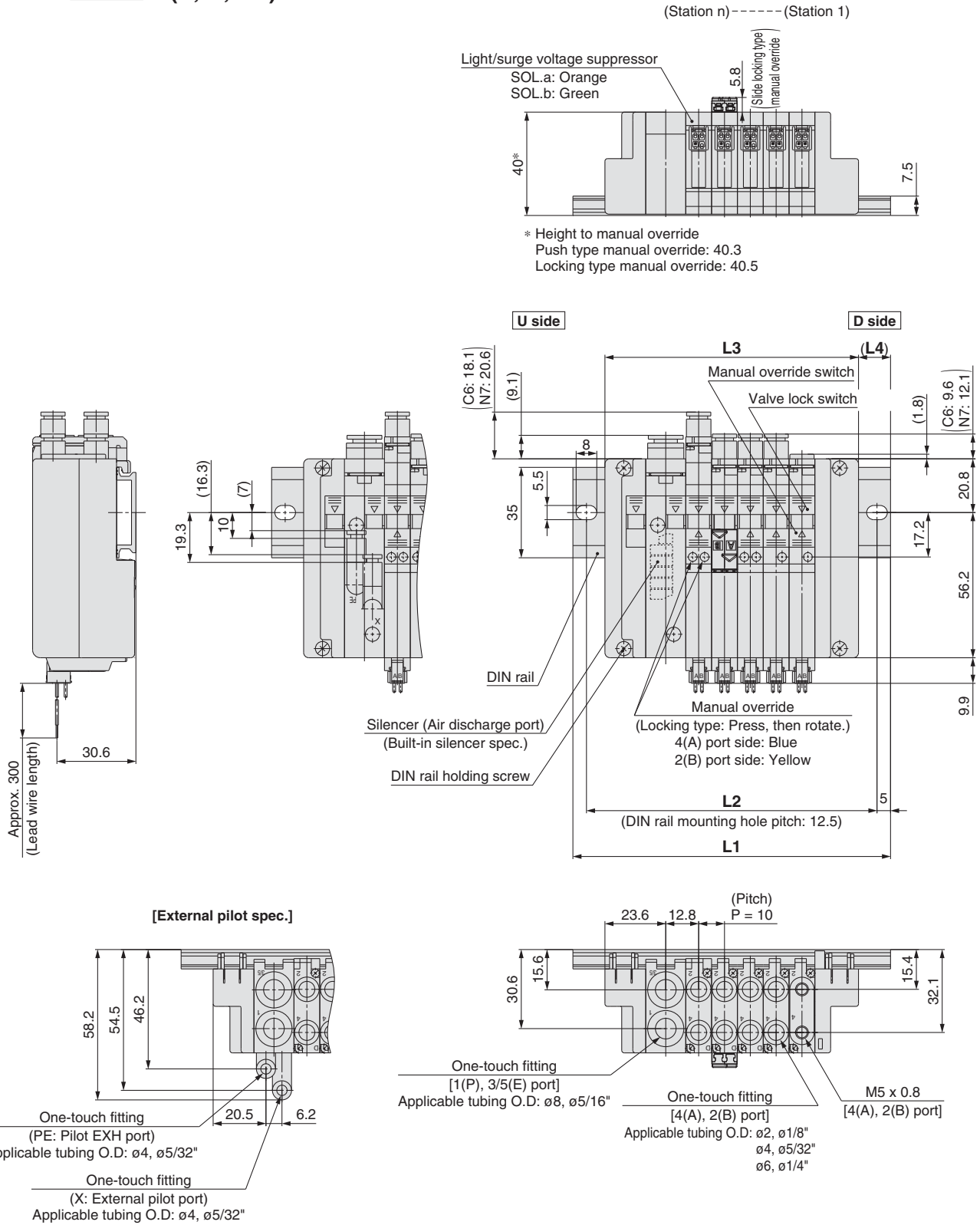

L: Dimensions

n: Stations

L \ n	1	2	3	4	5	6	7	8	9	10
L1	85.5	98	110.5	123	123	135.5	148	160.5	173	185.5
L2	75	87.5	100	112.5	112.5	125	137.5	150	162.5	175
L3	58.2	68.2	78.2	88.2	98.2	108.2	118.2	128.2	138.2	148.2
L4	13.5	14.5	16	17	12	13	14	15.5	16.5	17.5

Note) For manifold dimensions including elbow fitting, refer to page 32.

Dimensions

SS5J3-60- Stations B (S, R, RS)

SJ
2000
3000

Common
Specifications

Construction

Connector Type/
Cable Type **Plug-in**

Individual
Wiring **Non plug-in**

Manifold
Options

Made to
Order

SJ3A6

Common Specifications/
Construction

Connector Type/
Cable Type **Plug-in**

Individual
Wiring **Non plug-in**

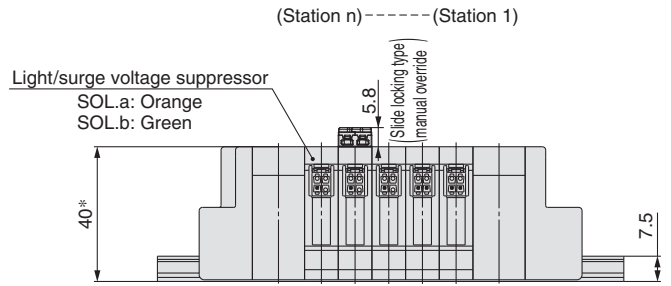

* Height to manual override
Push type manual override: 40.3
Locking type manual override: 40.5

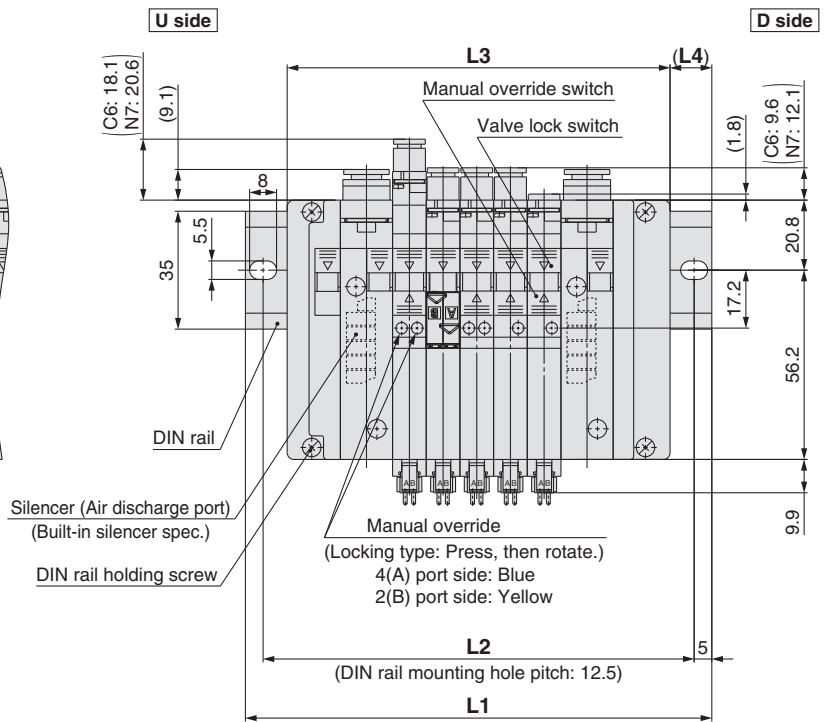
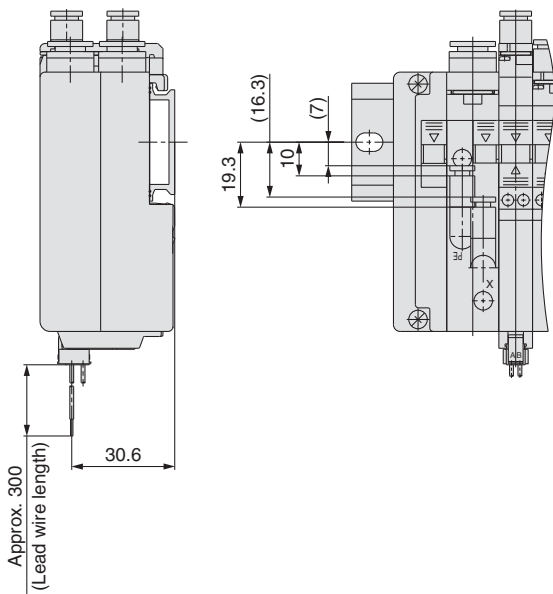

[External pilot spec.]

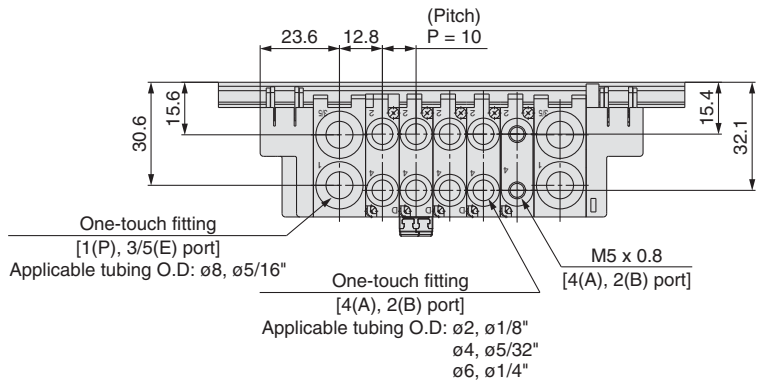
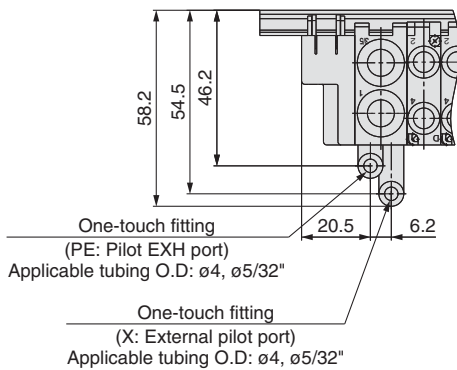

Note) For manifold dimensions including elbow fitting, refer to page 32.

L: Dimensions

		n: Stations																			
L \ n	1	2	3	4	5	6	7	8	9	10	11	12	13	14	15	16	17	18	19	20	
L1	98	110.5	123	135.5	148	148	160.5	173	185.5	198	210.5	210.5	223	235.5	248	260.5	260.5	273	285.5	298	
L2	87.5	100	112.5	125	137.5	137.5	150	162.5	175	187.5	200	200	212.5	225	237.5	250	250	262.5	275	287.5	
L3	73.7	83.7	93.7	103.7	113.7	123.7	133.7	143.7	153.7	163.7	173.7	183.7	193.7	203.7	213.7	223.7	233.7	243.7	253.7	263.7	
L4	12	13	14.5	15.5	16.5	11.5	12.5	14	15	16	17.5	12	13.5	14.5	15.5	17	11.5	13	14	15	

Series SJ2000/3000

Dimensions: SJ2000/3000 Mixed Manifold

SS5J3-M60- Stations U (S, R, RS)

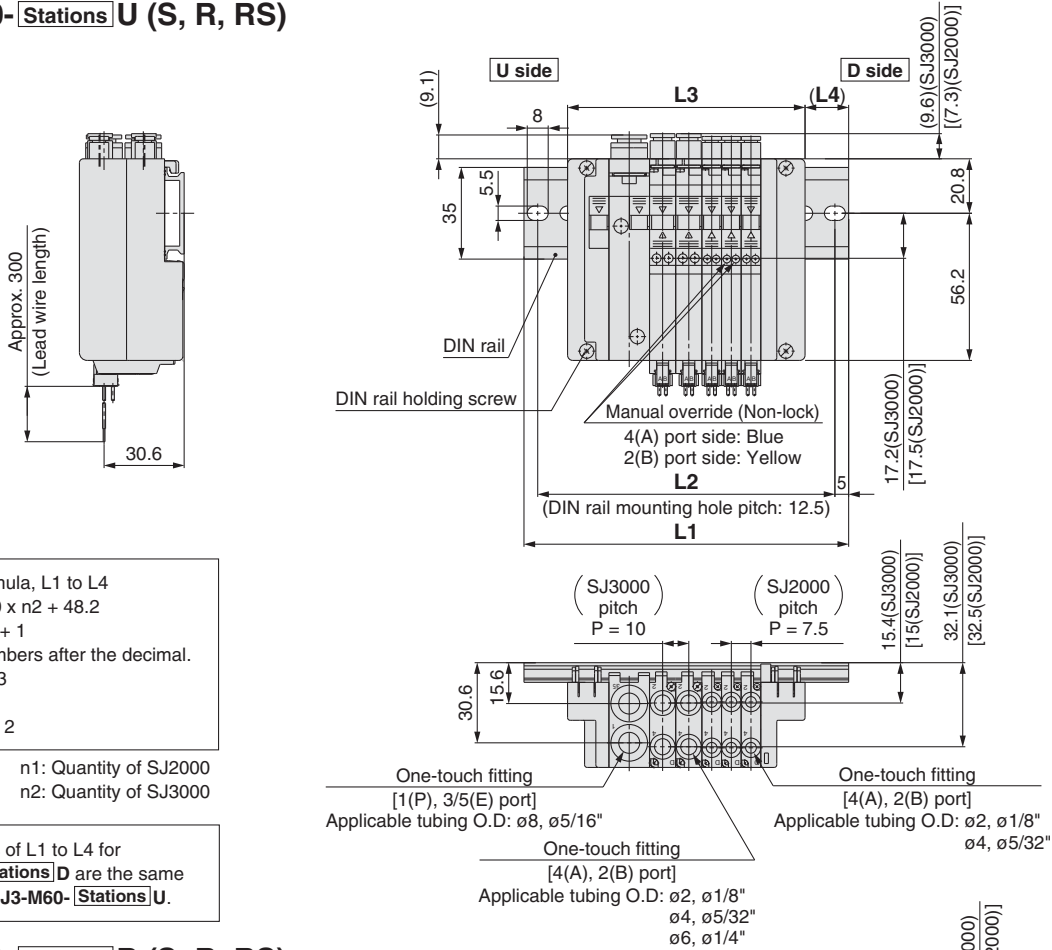

L dimension: Formula, L1 to L4
 $L3 = 7.5 \times n1 + 10 \times n2 + 48.2$
 $M = (L3 + 4) / 12.5 + 1$
 Remove all numbers after the decimal.
 $L1 = M \times 12.5 + 23$
 $L2 = L1 - 10.5$
 $L4 = (L1 - L3) / 2 - 2$

n1: Quantity of SJ2000
 n2: Quantity of SJ3000

* The dimensions of L1 to L4 for SS5J3-M60- Stations D are the same as those of SS5J3-M60- Stations U.

SS5J3-M60- Stations B (S, R, RS)

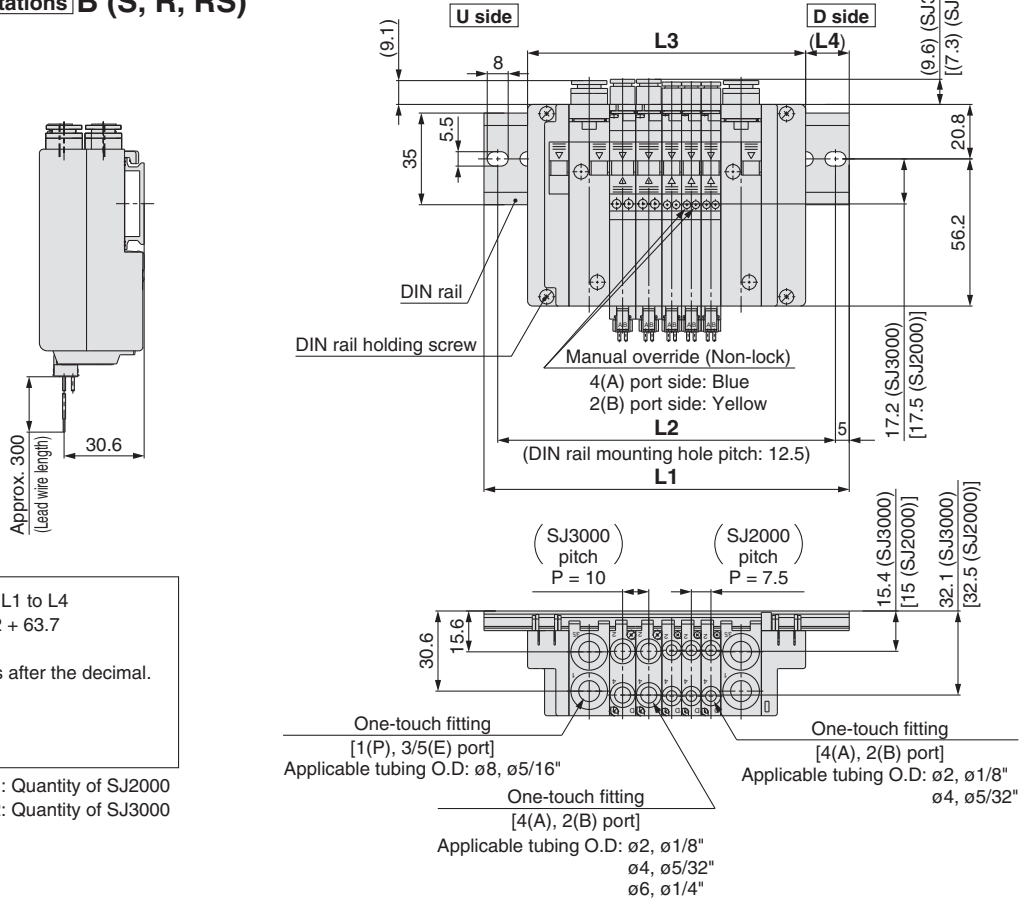

L dimension: Formula, L1 to L4
 $L3 = 7.5 \times n1 + 10 \times n2 + 63.7$
 $M = (L3 + 4) / 12.5 + 1$
 Remove all numbers after the decimal.
 $L1 = M \times 12.5 + 23$
 $L2 = L1 - 10.5$
 $L4 = (L1 - L3) / 2 - 2$

n1: Quantity of SJ2000
 n2: Quantity of SJ3000

Series SJ2000/3000 Manifold Exploded View

Individual Wiring

Type 60 individual wiring (Non plug-in) manifold

Note) Refer to page 58 for "How to Increase Manifold Stations."

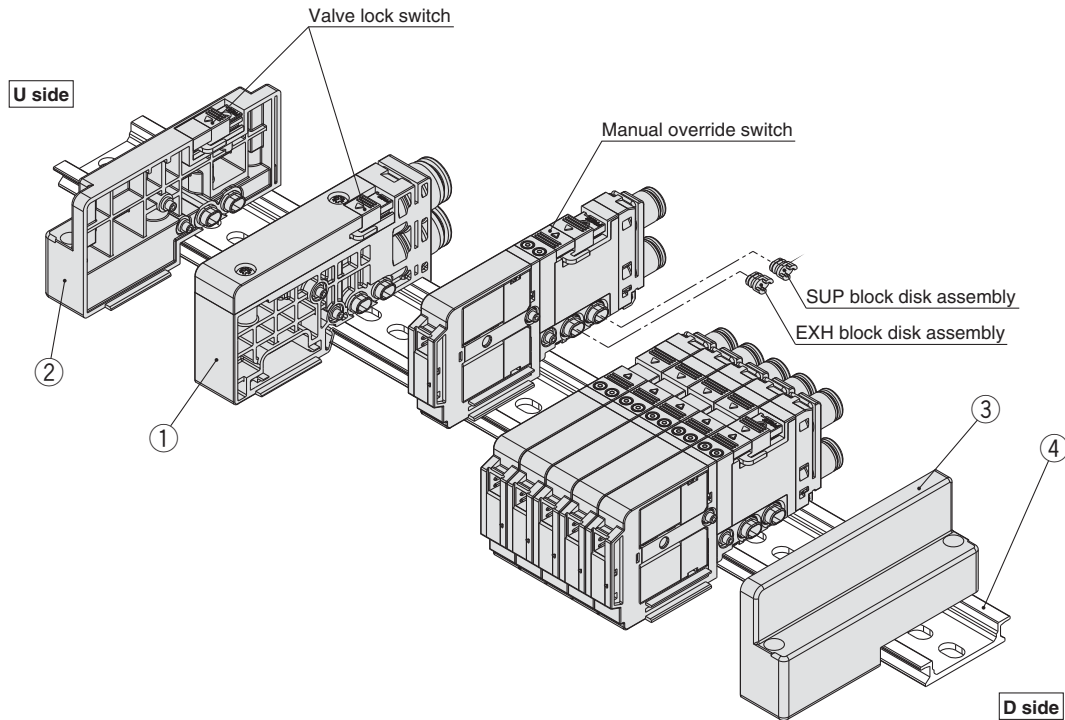

Component Parts/Individual Wiring (Non Plug-in)

No.	Description	Part no.	Note
1	Internal pilot	SJ3000-50-5A-□□	(Metric size) C6: With ø6 One-touch fitting (straight) C8: With ø8 One-touch fitting (straight) L6: With ø6 One-touch fitting (elbow upward entry) L8: With ø8 One-touch fitting (elbow upward entry) B6: With ø6 One-touch fitting (elbow downward entry) B8: With ø8 One-touch fitting (elbow downward entry)
	Internal pilot/Built-in silencer	SJ3000-50-5AS-□□	
	External pilot	SJ3000-50-5AR-□□ (X, PE port: Metric size ø4 Inch size ø5/32")	
	External pilot/Built-in silencer	SJ3000-50-5ARS-□□ (X port: Metric size ø4 Inch size ø5/32")	
	For different pressures, internal pilot ^{Note 1)}	SJ3000-50-6A-□□	
	For different pressures, internal pilot/Built-in silencer ^{Note 1)}	SJ3000-50-6AS-□□	
2	End block assembly	SJ3000-53-1A	For U side
3	End block assembly	SJ3000-53-2A	For D side
4	DIN rail	VZ1000-11-1-□	Refer to page 71.

Note 1) The valves cannot be operated only with the SUP/EXH block assembly for different pressure, select them in combination with the SUP/EXH block assembly for internal/external pilot.

Note 2) Refer to page 69 about the SUP/EXH block disk assembly and method of handling of parts at different pressure.

SJ
2000
3000

Common
Specifications

Construction

Connector Type/
Cable Type

Plug-in
Non plug-in
Individual
Wiring

Manifold
Options

Made to
Order

SJ3A6

Common Specifications/
Construction

Plug-in
Connector Type/
Cable Type

Non plug-in
Individual
Wiring

Series SJ2000/3000 Manifold Options 1

Common to Connector Type/Cable Type/Individual Wiring

■ SUP block disk assembly

By placing a SUP block disk assembly in a manifold valve's pressure supply passage, two different high and low pressures can be supplied to one manifold. When supplying different pressures using the manifold of the internal pilot, fill out a manifold specification sheet to place an order for an SUP/EXH block assembly for the internal pilot specifications and another SUP/EXH block assembly for the different pressure internal pilot specifications (Refer to Circuit Diagram 1).

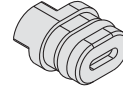

Series	Part no.
SJ2000	SJ3000-44-1A
SJ3000	

[Different pressure pneumatic circuit diagram]

● The SJ series supplies air to the pilot port of each valve using a 1(P) port of the SUP/EXH block assembly. When using in situations such as where there are different pressures, combine SUP/EXH block assemblies for internal pilot, external pilot and different-pressure by referring to the circuit below.

1. Different-pressure spec. using the internal pilot

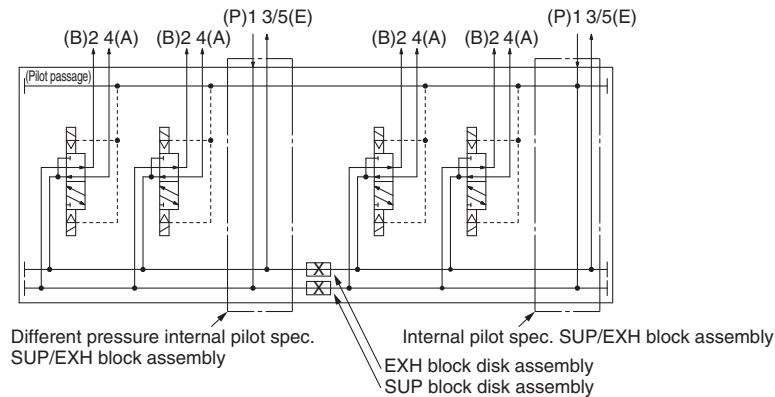

2. Different-pressure spec. using the external pilot (For using the SUP/EXH block assembly for external pilot)

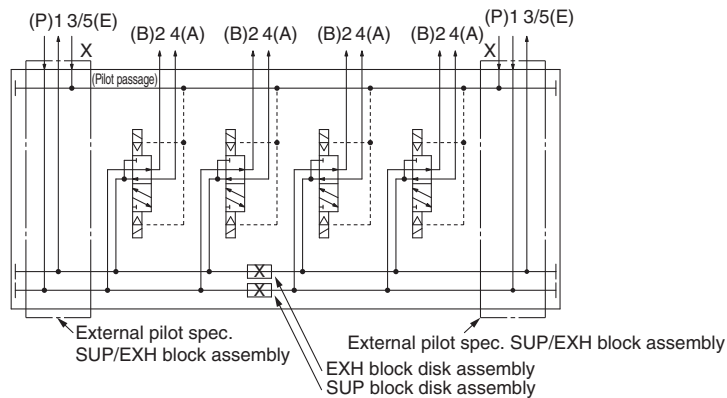

3. Different-pressure spec. using the external pilot (For using the SUP/EXH block assembly for different-pressure internal pilot spec.)

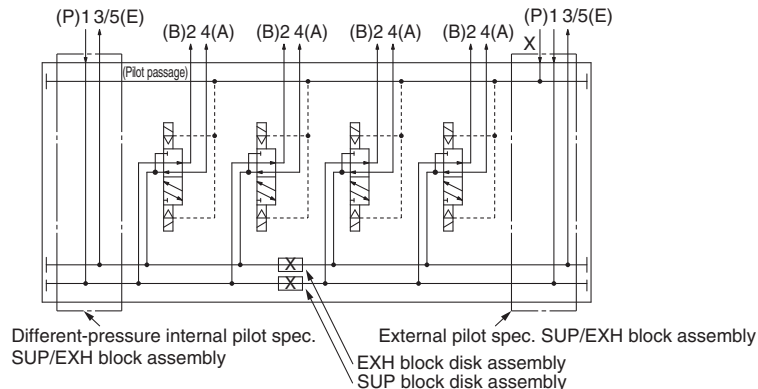

Note 1) When operating under the different-pressure spec., supply the higher pressure to the pilot passage.

Note 2) If there is a need to partition the pilot passage, consult SMC.

Series SJ2000/3000 Manifold Options 2

Common to Connector Type/Cable Type/Individual Wiring

EXH block disk assembly

By installing an EXH block disk in a manifold valve's exhaust passage, the valve's exhaust can be separated so that it will not affect other valves.

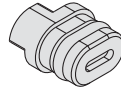

Series	Part no.
SJ2000	SJ3000-44-1A
SJ3000	

Label for block disk

These labels are attached to manifolds in which SUP and EXH block disks have been installed, in order to identify the installed locations. (Three sheets each included.)

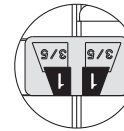
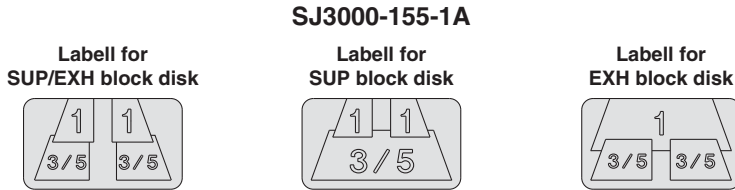

* When a block disk is concurrently ordered by specifying on the manifold specification sheet, etc., a label will be stuck on the position where block disk is mounted.

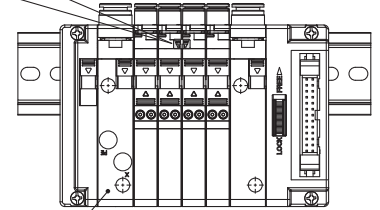

Internal pilot spec. for different pressure SUP/EXH block assembly

Blanking block assembly

These are mounted when later addition of valves is planned, etc.

<Connector type/Individual wiring>

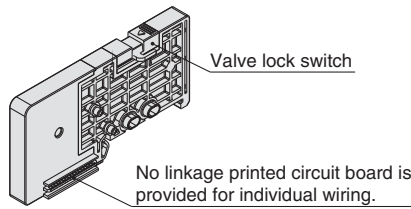

<Cable type>

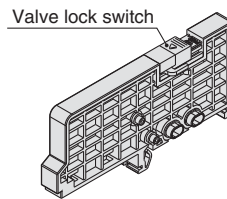

SJ2000

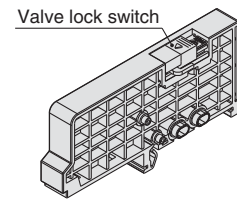

SJ3000

Series	Part no.	Note	Width
SJ2000	SJ3000-49-1A	Connector type (Single wiring)	7.5 mm
SJ3000	SJ3000-49-2A	Connector type (Double wiring)	
SJ3A6 (Note)	SJ3000-49-2A-N	Connector type (Double wiring)	
SJ2000	SJ3000-49-3A	Individual wiring	7.5 mm
SJ3000			
SJ3A6 (Note)	SJ3000-49-3A-N		

Series	Part no.	Width
SJ2000	SJ2000-49-4A	7.5 mm
SJ3000	SJ3000-49-4A	10 mm
SJ3A6 (Note)	SJ3000-49-4A-N	

Note) Valve lock switch is not available for the SJ3A6.

Note) Valve lock switch is not available for the SJ3A6.

Silencer with One-touch fitting

This silencer can be mounted on the manifolds' port 3/5 (E: Exhaust) with a single touch.

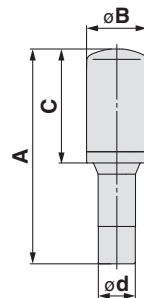

Series	Model	Effective area	A	B	C	ød
For SJ2000 SJ3000 (ø8)	AN15-C08	20 mm ²	45 mm	13 mm	20 mm	ø8

Plug

These are inserted in unused cylinder ports and P, E ports.

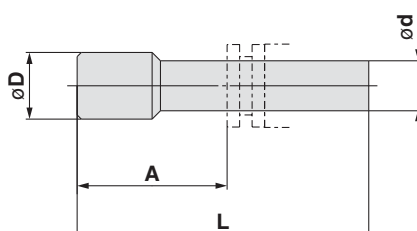

Dimensions

Applicable fitting size ød	Model	[mm]		
		A	L	D
2	KJP-02	8.2	17	3
4	KQ2P-04	16	32	6
6	KQ2P-06	18	35	8
8	KQ2P-08	20.5	39	10
1/8"	KQ2P-01	16	31.5	5
5/32"	KQ2P-03	16	32	6
1/4"	KQ2P-07	18	35	8.5
5/16"	KQ2P-09	20.5	39	10

Series SJ2000/3000 Manifold Options 3

Common to Connector Type/Cable Type/Individual Wiring

■ DIN rail

VZ1000-11-1-□

● L dimension

* Enter a number from the DIN rail dimension table shown below.

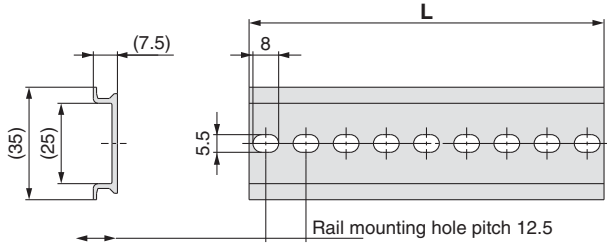

No.	S1	0	1	2	3	4	5	6	7	8	9
L dimension	85.5	98	110.5	123	135.5	148	160.5	173	185.5	198	210.5
Weight (g)	15.4	17.6	19.9	22.1	24.4	26.6	28.9	31.1	33.4	35.6	37.9

No.	10	11	12	13	14	15	16	17	18	19
L dimension	223	235.5	248	260.5	273	285.5	298	310.5	323	335.5
Weight (g)	40.1	42.4	44.6	46.9	49.1	51.4	53.6	55.9	58.1	60.4

No.	20	21	22	23	24	25	26	27	28	29
L dimension	348	360.5	373	385.5	398	410.5	423	435.5	448	460.5
Weight (g)	62.6	64.9	67.1	69.4	71.6	73.9	76.1	78.4	80.6	82.9

(Unit: mm)

■ Flat ribbon cable assembly

AXT100-FC□¹/₂/₃

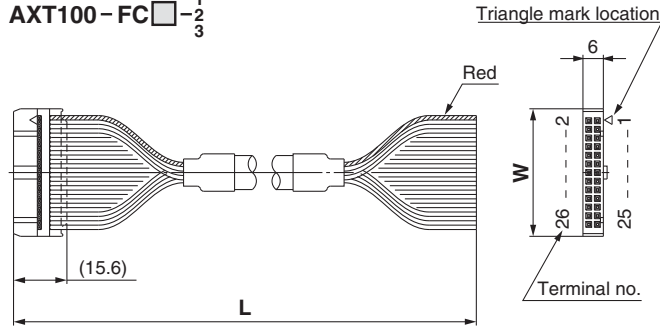

Flat Ribbon Cable Assembly

Cable length (L)	10 pins	20 pins	26 pins
1.5 m	AXT100-FC10-1	AXT100-FC20-1	AXT100-FC26-1
3 m	AXT100-FC10-2	AXT100-FC20-2	AXT100-FC26-2
5 m	AXT100-FC10-3	AXT100-FC20-3	AXT100-FC26-3
Connector width (W)	17.2	30	37.5

* For other commercial connectors, use a type with strain relief that conforms to MIL-C-83503.

Connector manufacturers:

- Hirose Electric Co., Ltd.
- Sumitomo 3M Limited
- Fujitsu Limited
- Japan Aviation Electronics Industry, Ltd.
- J.S.T. Mfg. Co., Ltd.

■ D-sub connector (25 pins)/Cable assembly

AXT100-DS25-⁰¹⁵/₀₃₀/₀₅₀

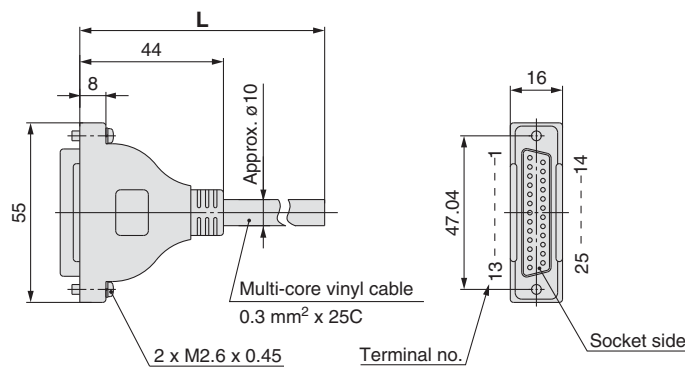

D-sub Connector Cable Assembly

Cable length (L)	Assembly part no.	Note
1.5 m	AXT100-DS25-015	Cable 25 cores x 24AWG
3 m	AXT100-DS25-030	
5 m	AXT100-DS25-050	

* For other commercial connectors, use a 25 pins type with female connector conforming to MIL-C-24308.

Connector manufacturers:

- Hirose Electric Co., Ltd.
- Fujitsu Limited
- Japan Aviation Electronics Industry, Ltd.
- J.S.T. Mfg. Co., Ltd.

Electric Characteristics

Item	Characteristics
Conductor resistance Ω/km, 20°C	65 or less
Withstand pressure VAC, 1 min	1000
Insulation resistance MΩkm, 20°C	5 or less

Note) The minimum bending radius for D-sub connector cables is 20 mm.

D-sub Connector Cable Assembly

Cable Colour List of Each Terminal No.

Terminal no.	Lead wire colour	Dot marking
1	Black	None
2	Brown	None
3	Red	None
4	Orange	None
5	Yellow	None
6	Pink	None
7	Blue	None
8	Purple	White
9	Grey	Black
10	White	Black
11	White	Red
12	Yellow	Red
13	Orange	Red
14	Yellow	Black
15	Pink	Black
16	Blue	White
17	Purple	None
18	Grey	None
19	Orange	Black
20	Red	White
21	Brown	White
22	Pink	Red
23	Grey	Red
24	Black	White
25	White	None

Series SJ2000/3000 Manifold Options 4

Common to Connector Type/Cable Type/Individual Wiring

■ Dual flow fitting (Set for SJ3000 series)

SJ3000-120-1A-C8

● Port size

C8	ø8
N9	ø5/16"

This is a fitting for cylinder ports which enables simultaneous actuation and increase in flow rate of valves for 2 stations.
This is a One-touch fitting with port sizes of ø8 and ø5/16.

* When arranging mounted to the valve, arrange the valve part no. using the part no. without the One-touch fitting, and then add the part no. for the dual flow fitting.
If the arrangement is complicated, please specify them by means of the manifold specification sheet.

Ordering example

Valve type (without One-touch fitting)

SJ3160-5CU-C0 2 sets

* SJ3000-120-1A-C8 1 set

↳ The asterisk denotes the symbol for assembly.

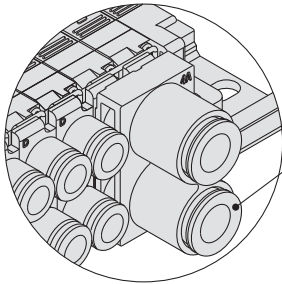

C8: ø8 One-touch fitting
N9: ø5/16" One-touch fitting

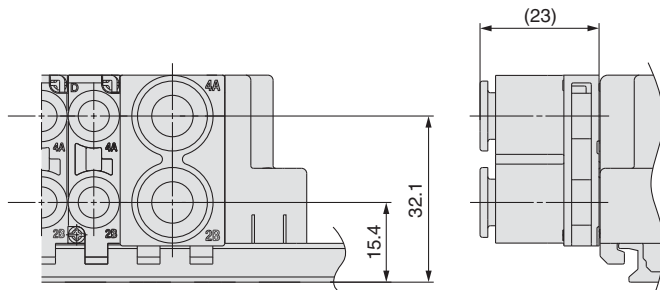

SJ
2000
3000

Common
Specifications

Construction

Plug-in

Connector Type/
Cable Type

Non plug-in

Individual
Wiring

Manifold
Options

Made to
Order

SJ3A6

Common Specifications/
Construction

Plug-in

Connector Type/
Cable Type

Non plug-in

Individual
Wiring

Series SJ2000/3000 Manifold Options 5

For Connector type/Individual Wiring

Regulator block/How to Order

This is used to reduce the pressure supplied from the D side inside the manifold.
All valves on the U side are depressurized from the regulator block.

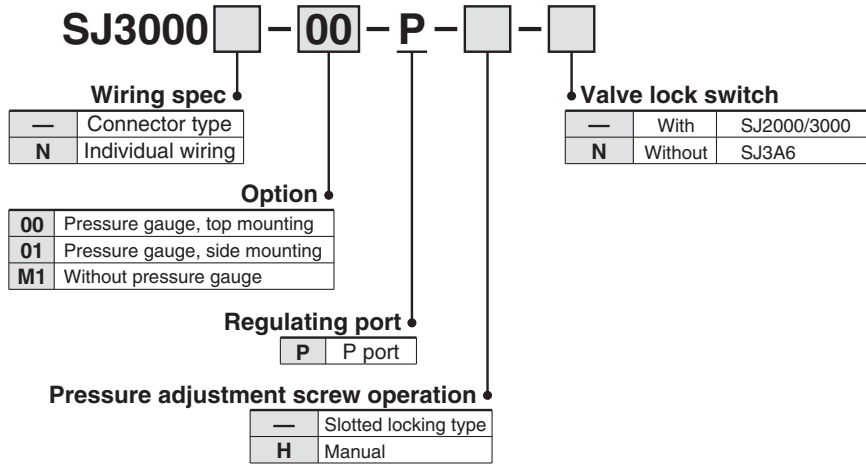

Note 1) Be sure to apply the pressure from the 1(P) port of the manifold before using the regulator block.

Note 2) When ordering with a regulator block installed in the manifold, please order using the manifold specification sheet.

SJ3000(N)-00-P(-H)

With manual operation of pressure adjustment screw

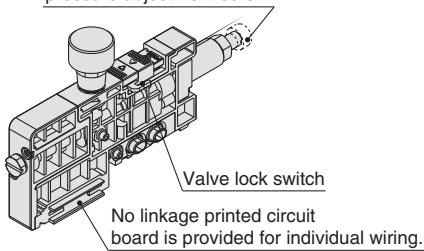

Pressure gauge, top mounting

SJ3000(N)-01-P(-H)

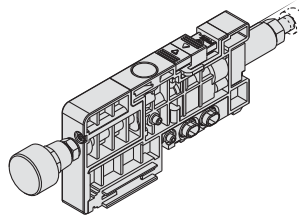

Pressure gauge, side mounting

SJ3000(N)-M1-P(-H)

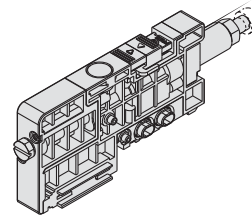

Without pressure gauge

Flow Characteristics (Conditions: Inlet pressure 0.7 MPa 2 position solenoid valve mounting)

SJ2000

P port regulation (P→A, B)

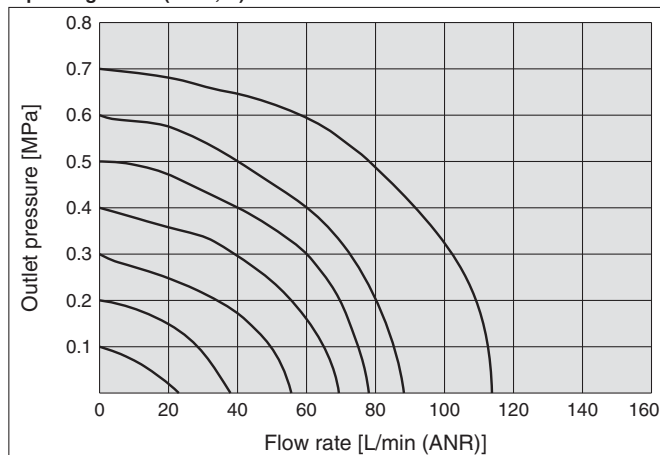

SJ3000

P port regulation (P→A, B)

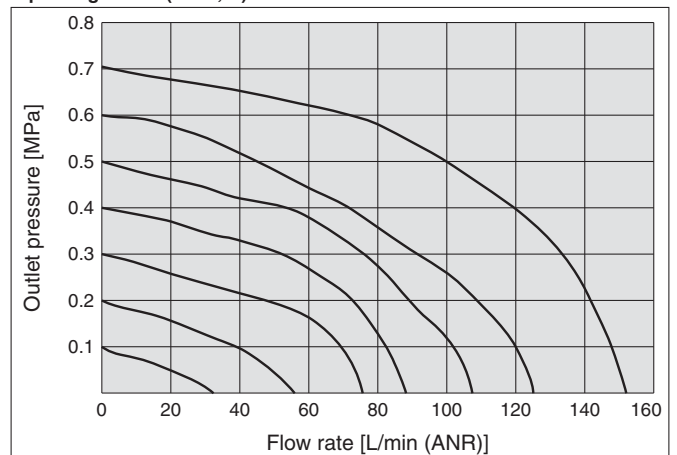

Series SJ2000/3000 Manifold Options 6

■ Pneumatic circuit (Regulator block mounting example)

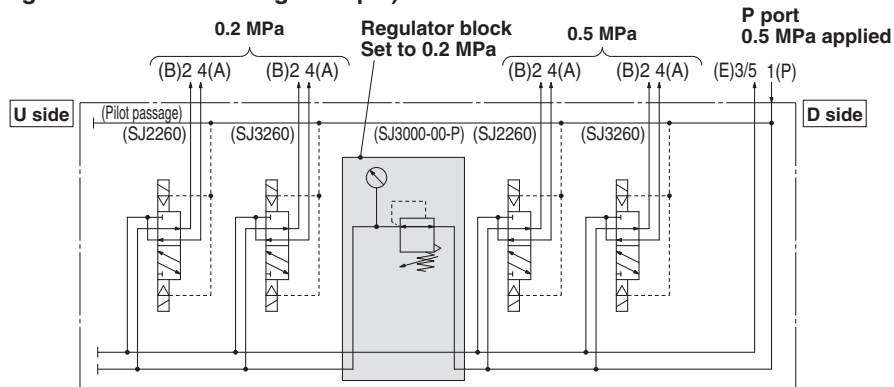

Note) Reduces supply pressure from the D side of manifold.
Supply pressure from the U side cannot be reduced.

■ Dimensions

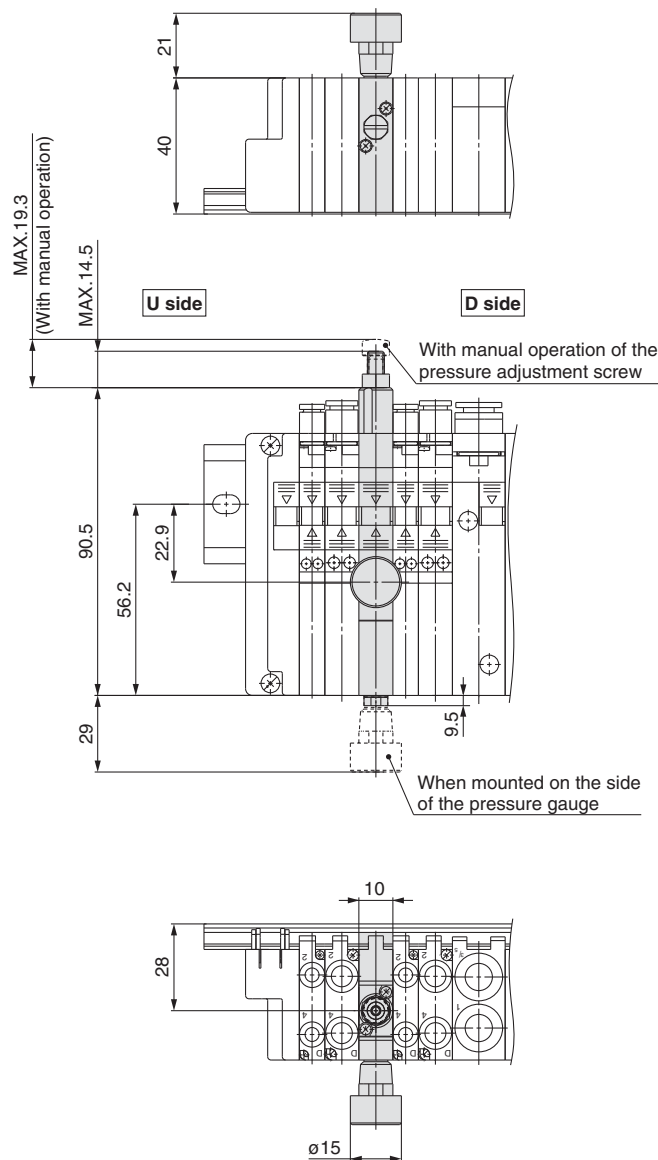

SJ
2000
3000

Common
Specifications

Construction

Connector Type/
Cable Type

Plug-in

Non plug-in

Individual
Wiring

Manifold
Options

Made to
Order

SJ3A6

Common Specifications/
Construction

Plug-in

Connector Type/
Cable Type

Non plug-in

Individual
Wiring

Series SJ2000/3000 Manifold Options 7

For Connector Type/Individual Wiring

■ SUP/EXH block assembly with regulator and pressure switch (for internal pilot manifold)/How to Order

* When mounting on the manifold, specify it in the manifold specification sheet.

SJ3000 **A** **—** **P** **—** **C8** **—** **N** **—** **—** **F**

Handle (Regulator orientation)

A	Lateral
B	Upward

* Refer to Figure 1.

Wiring spec.

—	For connector type
N	For individual wiring

1(P) port regulation

Fitting size

Straight (Metric size) C6: ø6 One-touch fitting C8: ø8 One-touch fitting (Inch size) N7: ø1/4" One-touch fitting N9: ø5/16" One-touch fitting
Elbow fitting (Upward entry) (Metric size) L6: ø6 One-touch fitting L8: ø8 One-touch fitting
Elbow fitting (Downward entry) (Metric size) B6: ø6 elbow fitting B8: ø8 elbow fitting

Note) When the handle orientation is lateral, the elbow fitting (upward entry) cannot be selected.

Regulator specifications (0.7 MPa specifications)

Symbol	Specifications
—	Relieving
2	Non-relieving

Pressure switch/pressure gauge specifications

—	Without pressure display function		
A	Analogue pressure gauge		
N	Digital pressure switch	NPN open collector	External wiring
Q		PNP open collector	Internal wiring
P	Digital pressure switch	PNP open collector	External wiring
S		PNP open collector	Internal wiring

Note 1) "Internal wiring" specifications mean that the wiring is assigned to the centralised wiring on the manifold. (For details, refer to "Electrical Wiring" on page 78.)
 Note 2) For the internal wiring specifications, select an appropriate pressure switch according to the polarity of the valve to be mounted.
 Note 3) For the serial manifold and non plug-in, "Q" and "S" (internal wiring specifications) cannot be selected.
 Note 4) The analogue pressure gauge is not applicable to the copper-free specifications.

Pressure switch/Pressure gauge display orientation

—	Without pressure display function
F	Fitting side
D	D side
C	Coil side
U	U side

* Refer to Figure 2.
 Note) If "D" is selected when the connector (D-sub connector, flat ribbon cable, PC wiring) entry direction is upward, the connector may interfere with the pressure switch wiring depending on the mounting position. So, carefully check this point.

Digital pressure switch option (external wiring)

—	Without lead wire with connector
L	With lead wire with connector

Note) This option can be selected only when the pressure switch/pressure gauge specifications are "N" or "P".

Display unit

— ⁽¹⁾	Analogue pressure gauge: The unit of the product nameplate and pressure display is MPa.
Z ⁽²⁾⁽³⁾	Analogue pressure gauge: The unit of the product nameplate and pressure display is psi.
ZA ⁽²⁾⁽⁴⁾	Digital pressure switch: With display unit switching function (Initial valve MPa.)

Note 1) Digital pressure switch, you will (MPa) a fixed unit.
 Note 2) According to the New Measurement Law (SI units are used in Japan), these pressure gauges are sold only to the overseas market. Both "MPa" and "psi" are written on the unit display of the digital pressure switch.
 Note 3) The digital pressure switch has the unit conversion function and its initial setting is the "psi" display.
 Note 4) For digital pressure switches.

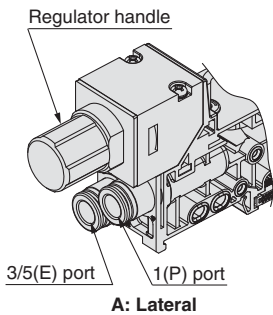

Fig.1 Handle orientation (Regulator mounting orientation)

- Note 1) Be sure to apply the pressure from the 1(P) port of the manifold before using the SUP/EXH block assembly with regulator and pressure switch.
 Note 2) For details on regulator and electric circuit of the external wiring specifications, see the catalogue for Series ARM11.
 Note 3) Applicable only to the manifolds with the internal pilot specifications.
 Note 4) This regulator block cannot be combined with the vacuum release valve of Series SJ3A6.

■ Series SJ3000 Valve with Speed Controller/How to Order

SJ3 **60** **(T)** **—** **—** **—** **—** **—** **—** **S** **0**

Entry is the same as standard products. **Control method**

0	Meter-out	Identification colour: Silver
1	Meter-in	Identification colour: Black

- Note 1) Applicable only to Series SJ3000.
 Note 2) Specify S0 or S1 at the end of the valve part no.

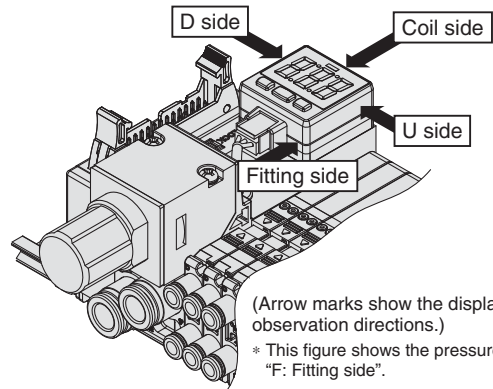
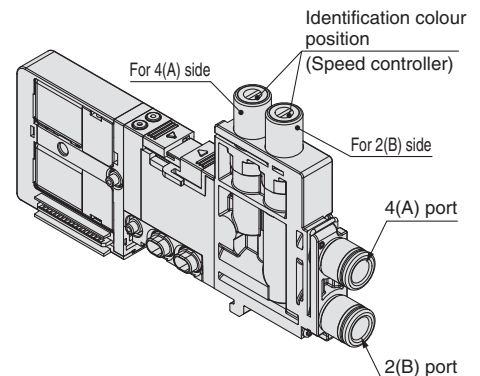

Fig.2 Pressure switch/pressure gauge display orientation symbol



Series SJ2000/3000

Manifold Options 8

Flow characteristics

Regulator unit flow characteristics
SJ2000 passage P→A/B

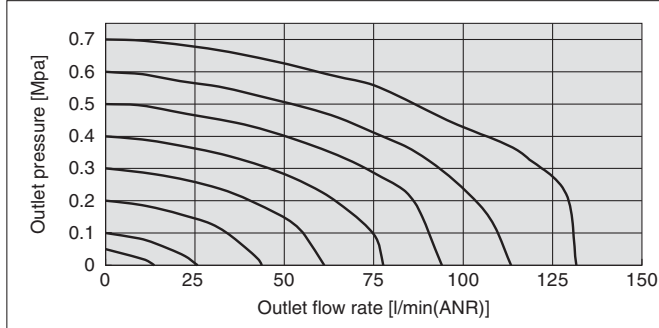

SJ3000 passage P→A/B

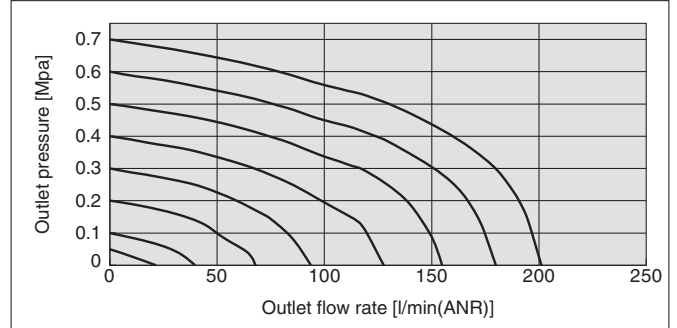

Valve with speed controller flow characteristics
Meter-out control A/B→E

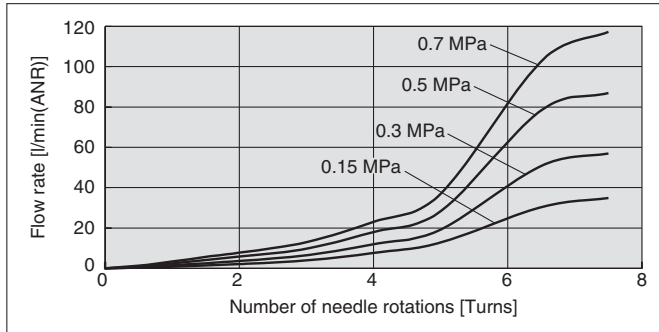

Meter-in control P→A/B

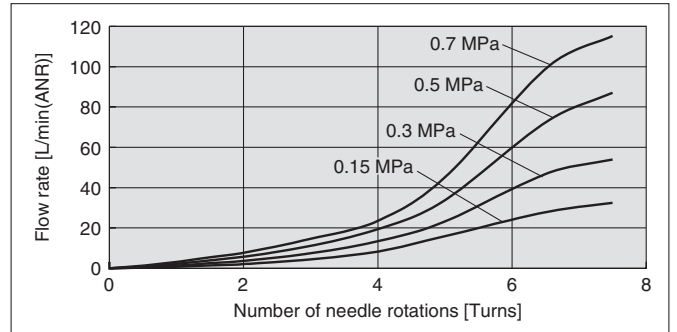

Pneumatic circuit

(Installation example of SUP/EXH block assembly with regulator and pressure switch, valve with speed controller)

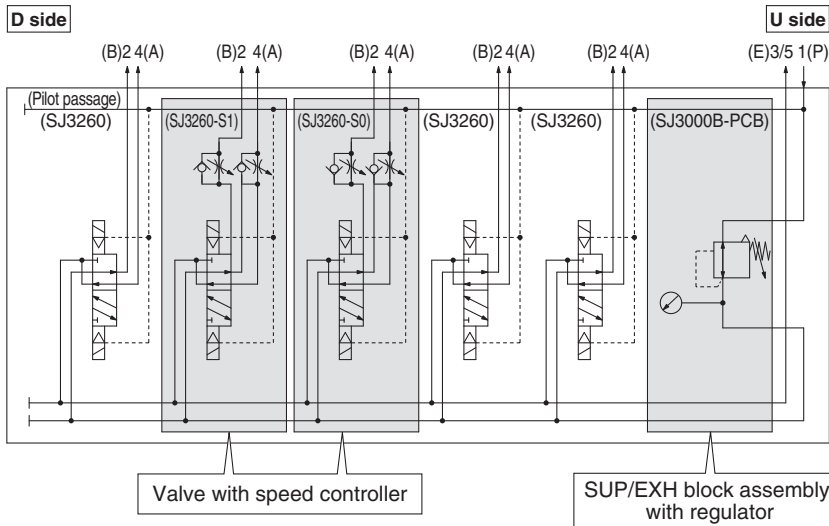

SJ
2000
3000

Common
Specifications

Construction

Connector Type/
Cable Type

Plug-in
Non plug-in

Individual
Wiring

Manifold
Options

Made to
Order

SJ3A6
Common Specifications/
Construction

Plug-in
Connector Type/
Cable Type

Non plug-in
Individual
Wiring

Series SJ2000/3000 Manifold Options 9

For Connector Type/Individual Wiring

■ SUP/EXH block assembly with regulator and pressure switch, valve with speed controller/Dimensions

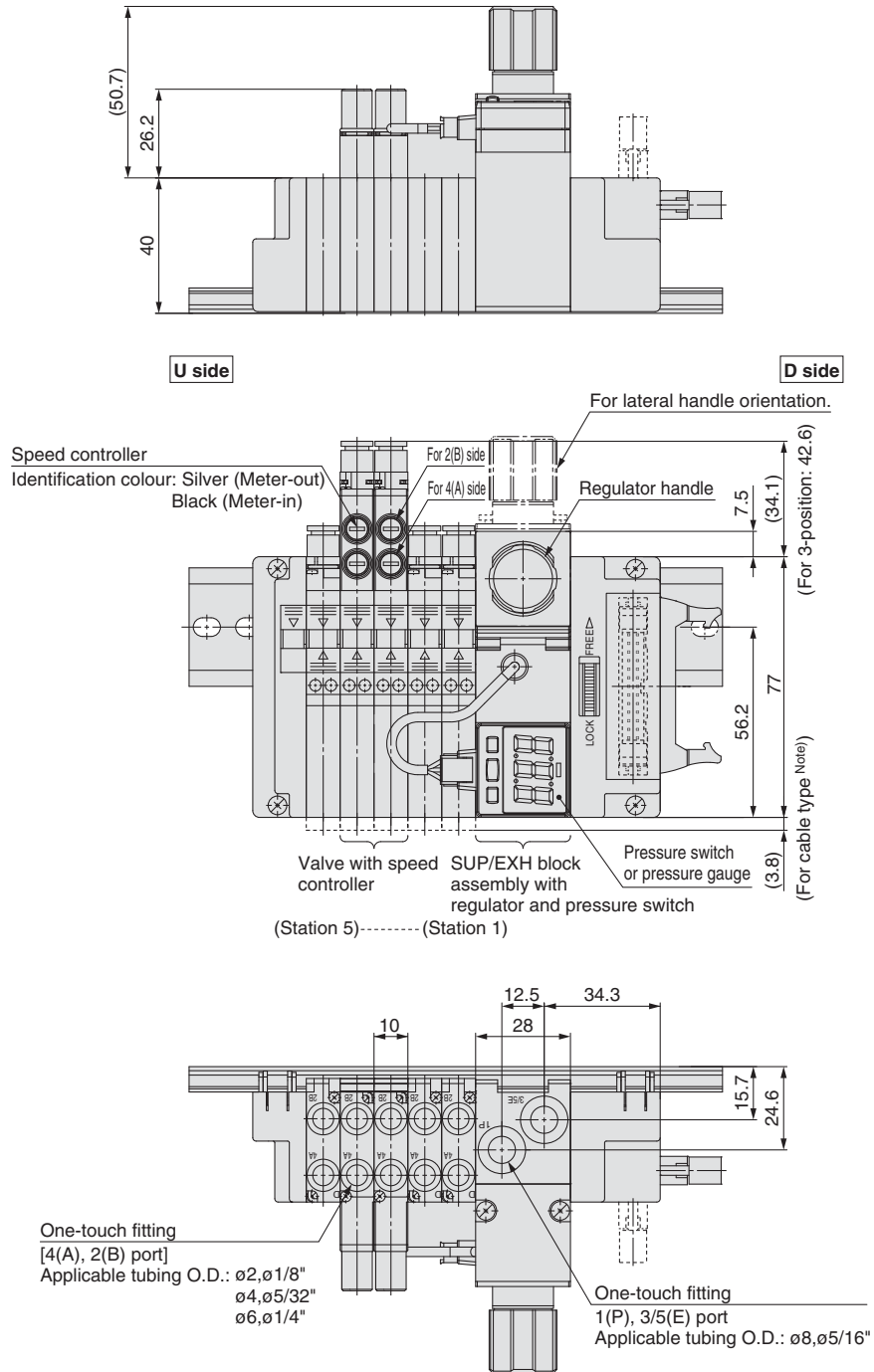

Note) The SUP/EXH block assembly with regulator and pressure switch cannot be mounted on the plug-in cable type manifold.

Series SJ2000/3000

Manifold Options 10

■ Manifold electrical wiring when the SUP/EXH block assembly with the regulator and pressure switch is mounted.
(Internal wiring and pressure switch (NPN))

D-sub connector (25 pins)

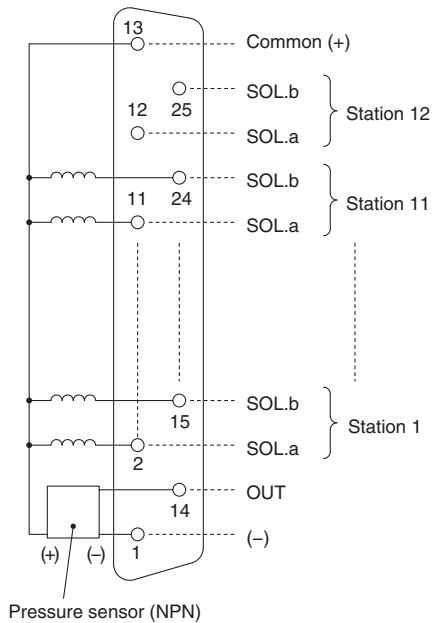

Flat ribbon cable (26 pins)

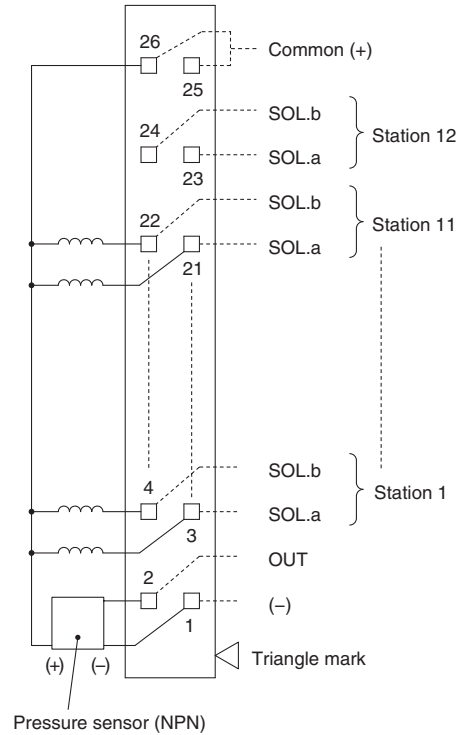

Flat ribbon cable (20 pins)

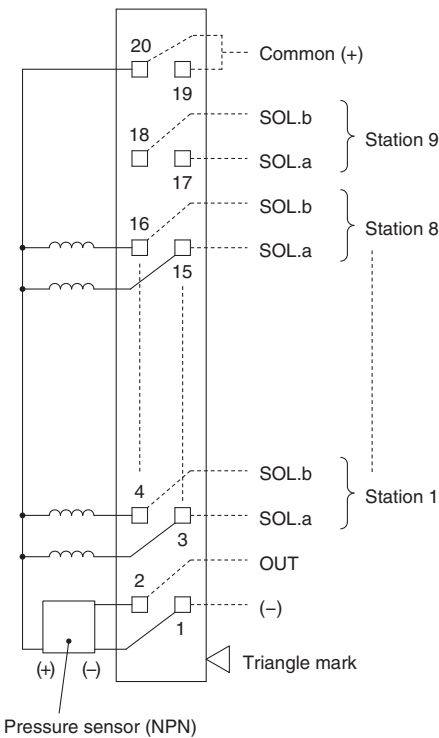

Flat ribbon cable (10 pins)

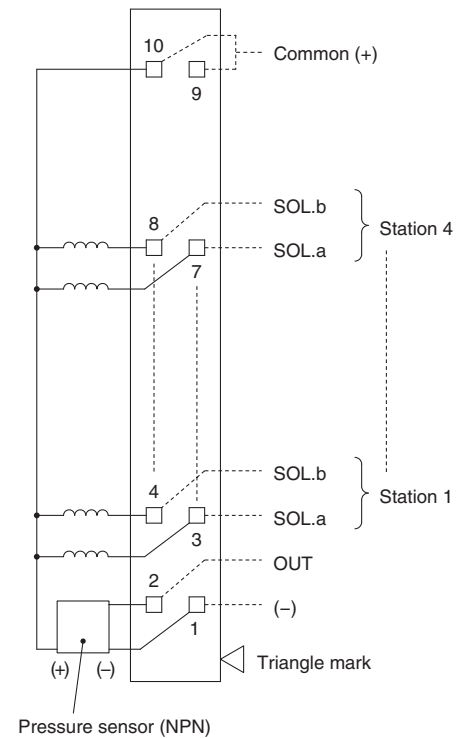

Note 1) This figure shows when the SUP/EXH block assembly with the regulator and pressure switch is mounted between the connector block and 1st station valve.

Note 2) Applicable only to the connector type manifold.

Series SJ2000/3000

Manifold Options 11

For connector type

■ Intermediate connector block assembly

This connector block can be used by inserting it into the middle of the manifold.

This can be used, for example, when you wish to separate electrical control of valves in the same manifold, or when the number of control points is insufficient.

Series	Part no.	Note
SJ2000 SJ3000	SJ3000-76-1A	Flat ribbon cable (20 pins)
	SJ3000-76-4A	Flat ribbon cable (26 pins)
	SJ3000-76-2A-05	With power supply terminal (for PC wiring)

Note) When ordering with an intermediate connector block assembly installed in the manifold, please order using the manifold specification sheet.

■ Intermediate connector block assembly wiring example

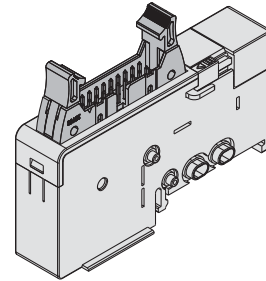
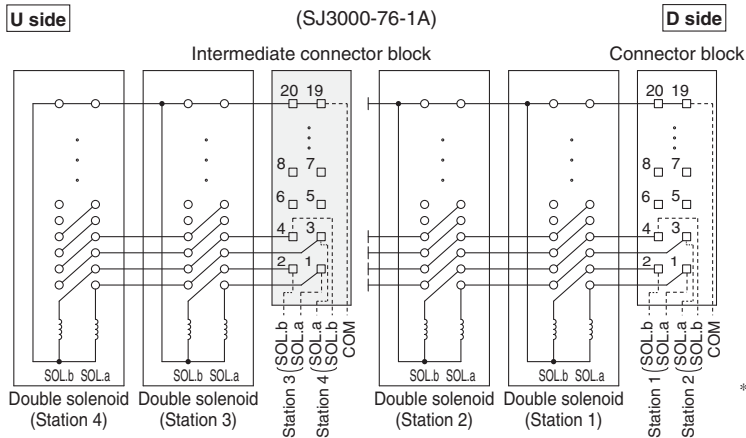

For flat ribbon cable (20 pins)

* Enables control of U side solenoid valves from the position where the intermediate connector block assembly is installed.

■ Dimensions

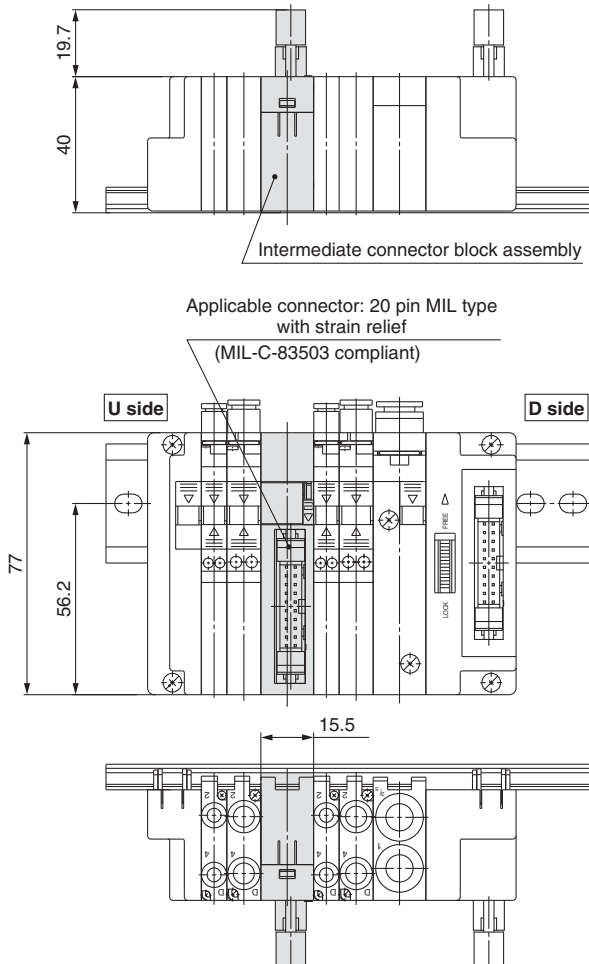

* This drawing shows the SJ3000-76-1A.

Series SJ2000/3000

Made to Order

For detailed dimensions, specifications, and delivery, please contact SMC.



SJ
2000
3000

Common Specifications

Construction

Connector Type/
Cable Type

Individual Wiring

Manifold Options

Made to Order

SJ3A6

Common Specifications/
Construction

Connector Type/
Cable Type

Individual Wiring

Symbol

-X90

1 Main Valve Fluororubber Specifications

Fluororubber is used for rubber parts of the main valve to allow use in applications such as the following.

1. When using a lubricant other than the recommended turbine oil, and there is a possibility of malfunction due to swelling of the spool valve seals.
2. When ozone enters or is generated in the air supply.

Part no. SJ $\frac{2}{3}$ 60 (T) - - - - X90

- Entry is the same as standard products.

Note) Because in series -X90 fluororubber is used for only main valve, the rubber parts of the application/usage in conditions requiring heat resistance should be avoided.

Vacuum Release Valve with Restrictor

Series *SJ3A6*

SJ
2000
3000

Common
Specifications

Construction

Connector Type/
Cable Type

Plug-in

Non plug-in

Individual
Wiring

Manifold
Options

Made to
Order

SJ3A6

Common Specifications/
Construction

Connector Type/
Cable Type

Plug-in

Non plug-in

Individual
Wiring

Plug-in Type

P.85

Connector Connection

D-sub Connector
Flat Ribbon Cable
PC Wiring

Serial Wiring: EX180
Serial Wiring: EX510

P.87

Cable Connection

D-sub Connector
Flat Ribbon Cable

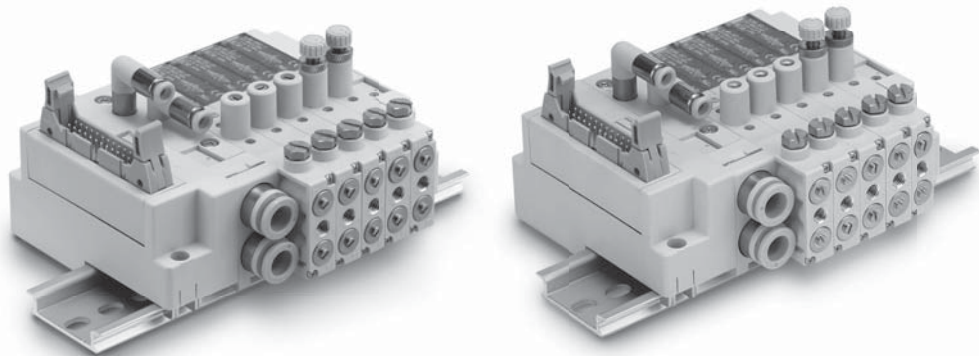

Non Plug-in Type Individual Wiring

P.91

Individual Wiring

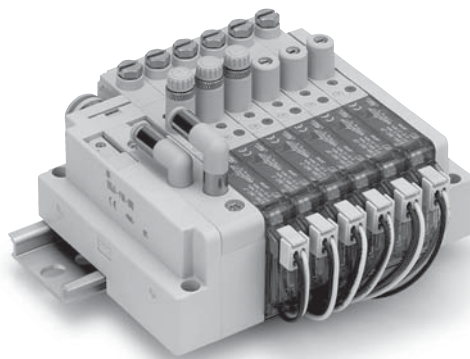

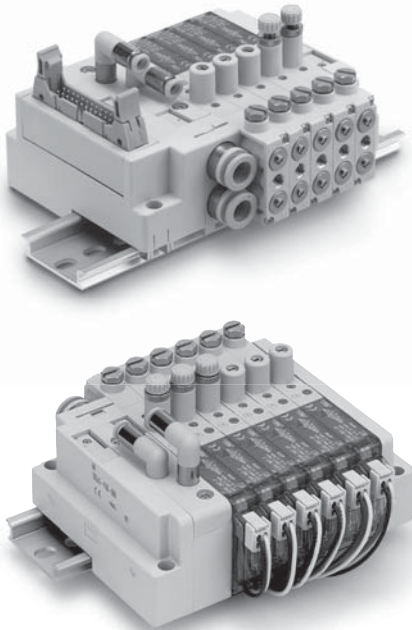

Manifold Valve Specifications

Valve construction		3 position 3 port valve with restrictor
Fluid		Air
Operating pressure range [MPa]	Release pressure port 1(P)	0.25 to 0.7
	Vacuum pressure port 3/5(E)	-100 kPa to 0.7 <small>Note 1)</small>
	Pilot X port	0.25 to 0.7 <small>Note 2)</small>
Ambient and fluid temperature [°C]		-10 to 50 (No freezing)
Max. operating frequency [Hz]		3
Manual override (Manual operation)		Non-locking push type
		Push-turn locking slotted type
Restrictor operation		Manual
		Slotted locking type
Pilot method		External pilot/Pilot valve individual exhaust
Lubrication		Not required
Mounting orientation		Unrestricted
Impact/Vibration resistance [m/s²] <small>Note 3)</small>		150/30
Enclosure		Dustproof

Note 1) Can be used with positive pressure to suit the application.

Note 2) Please use with pilot X port pressure equal to or higher than the release port 1(P) pressure.

Note 3) Impact resistance: No malfunction occurred when it is tested in the axial direction and at the right angles to the main valve and armature in both energized and de-energized states every once for each condition. (Values at the initial period)

Vibration resistance: No malfunction occurred in a one-sweep test between 45 and 2000 Hz. Test was performed at both energized and de-energized states in the axial direction and at the right angles to the main valve and armature. (Values at the initial period)

Symbol

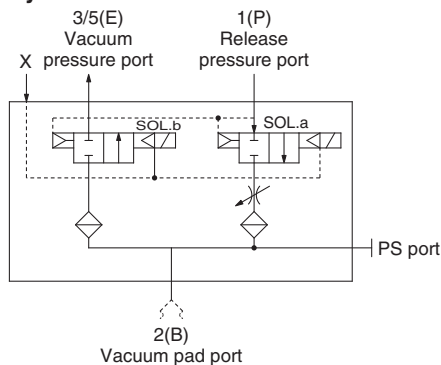

Solenoid Specifications

Coil rated voltage		24 VDC, 12 VDC
Allowable voltage fluctuation		±10% of rated voltage *
Power consumption [W]	Standard	0.4
	With power saving circuit (Continuous duty type)	0.15
Surge voltage suppressor		Diode
Indicator type		LED

* For the allowable voltage fluctuation for Z/T type (with power saving circuit), please observe the following range because they have voltage drop due to internal circuit.

Z type 24 VDC: -7% to +10%

12 VDC: -4% to +10%

T type 24 VDC: -5% to +10%

12 VDC: -6% to +10%

Response Time

Valve model	Response time ms (at 0.5 MPa)
SJ3A6-□□-□	19 or less

Weight

Valve model	Weight [g]
SJ3A6-□□-P	79

Flow Characteristics

Flow Characteristics (When restrictor is fully open)

Valve model	Fluid passage	1(P)→2(B)			2(B)→3/5(E)		
	2(B) Port size	C[dm ³ /(s·bar)]	b	Cv	C[dm ³ /(s·bar)]	b	Cv
SJ3A6-□□-□	M5	0.24	0.19	0.05	0.40	0.18	0.10

Restrictor Flow Characteristics [Fluid passage: 1(P)→2(B)]

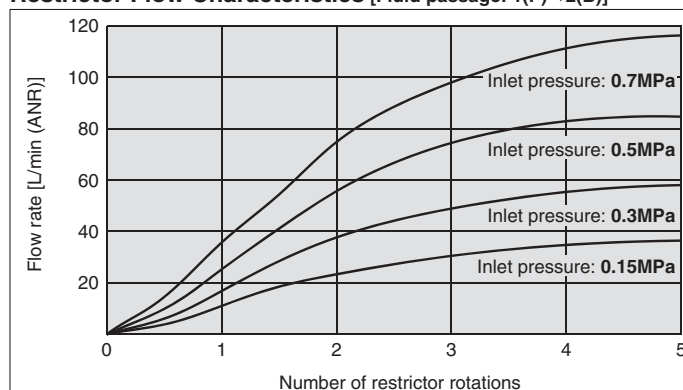

Series SJ3A6 Construction/Circuit Example

Construction

Connector type

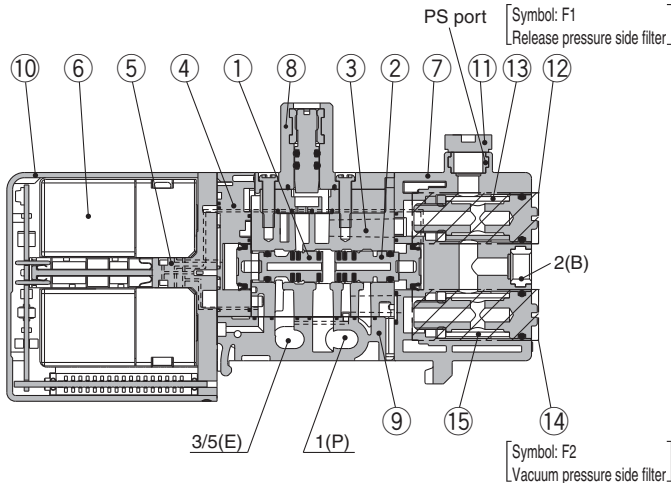

Cable type

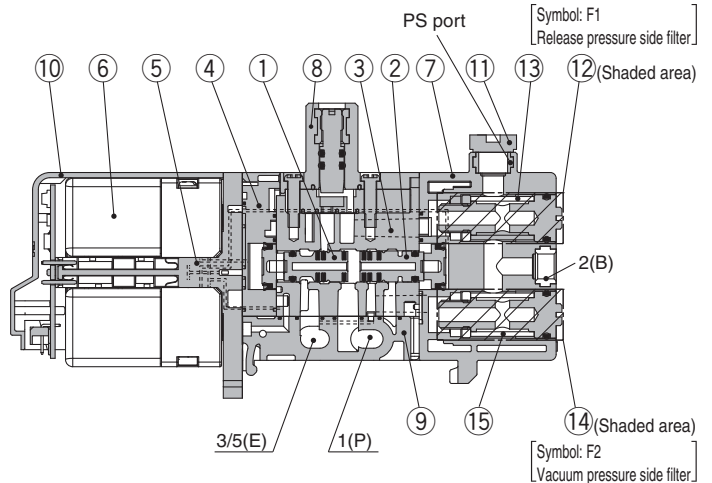

Component Parts

No.	Description	Material	Note
1	Spool valve assembly	Resin/HNBR	A side (for release pressure switching)
2	Spool valve assembly	Resin/HNBR	B side (for vacuum pressure switching)
3	Body	Zinc die-cast	—
4	Adapter plate	Resin	White
5	Pilot adapter	Resin	White
6	Pilot valve assembly	—	—
7	End cover	Resin	White
8	Restrictor block assembly ^{Note)}	Resin	White
9	Bottom cover	Resin	White
10	Light cover	Resin	Light blue

Note) Set the operating torque of the restrictor of the restrictor block assembly to 0.3 N·m or less.

Component Parts

No.	Description	Part no.	Note
11	Plug	M-5P	PS port with plug
12	Filter assembly	SJ3000-110-1A	1 μm White <Release pressure side>
13	Filter	SJ3000-107-1A	1 μm White <Release pressure side>, 5 pcs. included
14	Filter assembly	SJ3000-110-2A	30 μm Light purple <Vacuum pressure side>
15	Filter	SJ3000-107-2A	30 μm Light purple <Vacuum pressure side>, 5 pcs. included

<Filter replacement instructions>

If there are situations such as filter clogging, a drop in suction force, or slow response time, stop operation and replace the filter.

- Using a precision driver, remove the filter assembly (12 or 14) from the main unit.
- Turn the filter guide by hand and remove.
- Replace the filter (13 or 15) and gently hand tighten the filter guide. At this time, check that there is no foreign matter on the O-ring of the filter assembly.
- Return the filter assembly to the main unit. (Tightening torque: 0.12 N·m)

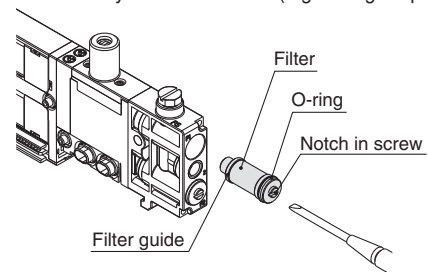

After tightening the plug (M-5P) with a tightening torque of 1 N·m, or manually tightening, use the tightening tool and tighten it by 1/4 turn.

- 12 14 Filter assembly (with filter) 13 15 Filter (5 pcs. included)

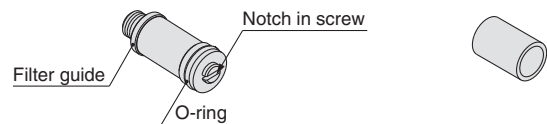

Adsorbing and Transferring System Circuit Example

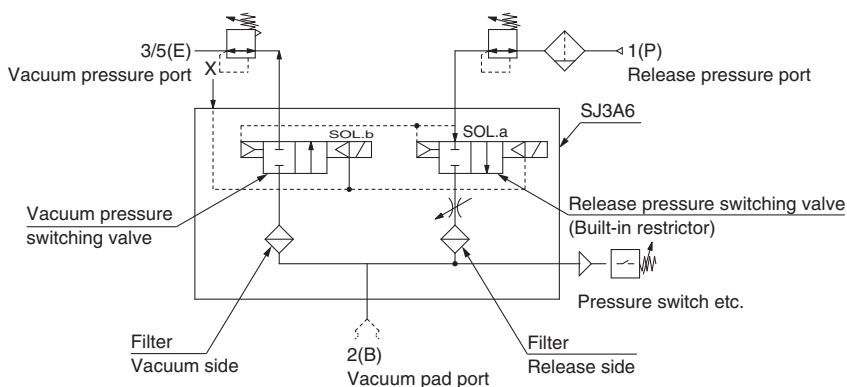

Plug-in Connector Type

Vacuum Release Valve with Restrictor

Series SJ3A6

An order cannot be placed with only the manifold part no. Be sure to order solenoid valves for mounting at the same time while referring to the ordering example.

How to Order

● Vacuum release valve manifold with restrictor

SS3J3-V60   - **05** **U**  

Vacuum release valve with restrictor type

Connector type

Symbol	Mounting position	Page	Note
FD	D-sub connector	P.15	Parallel wiring
PD	Flat ribbon cable 26 pins		
PGD	Flat ribbon cable 20 pins		
PHD	Flat ribbon cable 10 pins		
JD	Flat ribbon cable (PC wiring, without power supply terminal)	P.33	
GD	Flat ribbon cable (PC wiring, with power supply terminal)		
S□	EX180 serial transmission	P.41	Serial wiring
S6B	EX510 serial transmission	P.49	

Connector entry

With parallel wiring specifications, it is necessary to select the connector entry direction (1: upward, 2: lateral). (Only upward is available for GD.) For details, refer to pages 15 and 33.

DIN rail length specified

—	Standard length	
2	2 stations	Specify a longer rail than the standard length.
⋮	⋮	
16	16 stations	

* Specify the valve stations not exceeding the maximum stations.

SUP/EXH block mounting position

U	U side (1 to 10 stations)
D	D side (1 to 10 stations)
B	Both sides (1 to 16 stations)
M*	Special specifications

* Specify the required specifications (including port sizes other than ø8) by means of the manifold specification sheet.

SUP/EXH block fitting spec.

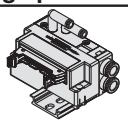
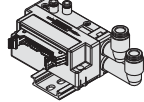
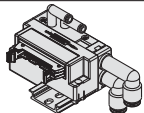
—	Straight fitting	
L	Elbow fitting (Upward)	
B	Elbow fitting (Downward)	

* There is no need to enter anything when the SUP/EXH block mounting position "M" is selected. Also, this manifold comes standard with external pilot specifications.

How to Order Manifold Assembly

Ordering example (SS3J3-V60PD2-□)

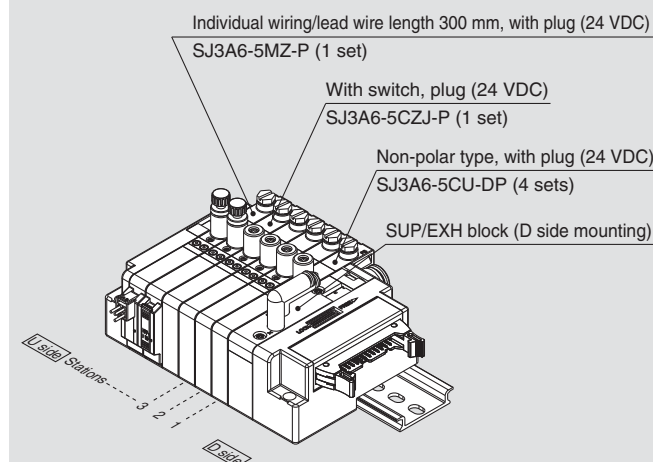

SS3J3-V60PD2-06D... 1 set (Manifold part no.)
 * **SJ3A6-5CU-DP**..... 4 sets (Non-polar type, with plug part no.)
 * **SJ3A6-5CZJ-P**..... 1 set (With switch, plug part no.)
 * **SJ3A6-5MZ-P**..... 1 set (Individual wiring, lead wire length 300 mm, with plug part no.)

→ The asterisk denotes the symbol for assembly. Prefix to the part no. of the solenoid valve, etc.

- The valve arrangement is numbered as the 1st station from D side.
 - Indicate the valves to be attached below the manifold part number, in order starting from station 1 as shown in the drawing. In the case of complex arrangement, specify them in the manifold specification sheet.
- Note) When ordering a manifold, specify the part nos. of valves to be mounted together. (An order cannot be placed with only the manifold part no.)

● Valve stations

F: D-sub connector

Symbol	Stations
01	1 station
⋮	⋮
12	12 stations

P: Flat ribbon cable (26 pins)

Symbol	Stations
01	1 station
⋮	⋮
12	12 stations

PG: Flat ribbon cable (20 pins)

Symbol	Stations
01	1 station
⋮	⋮
09	9 stations

PH: Flat ribbon cable (10 pins)

Symbol	Stations
01	1 station
⋮	⋮
04	4 stations

J: Flat ribbon cable (PC wiring)

Symbol	Stations
01	1 station
⋮	⋮
08	8 stations

S6B: EX510 serial transmission

Symbol	Stations
01	1 station
⋮	⋮
08	8 stations

G: Flat ribbon cable (PC wiring, with power supply terminal)

Symbol	Stations
01	1 station
⋮	⋮
08	8 stations

S□: EX180 serial transmission

Symbol	Stations	Note
01	1 station	There are limitations on the station number, depending on the serial type. Refer to page 41 for details.
⋮	⋮	
16	16 stations	

* The number of the blanking block assembly is also included. For the blanking block assembly, please select double wiring specifications.

How to Order Solenoid Valves (3 Position 3 Port with Restrictor)

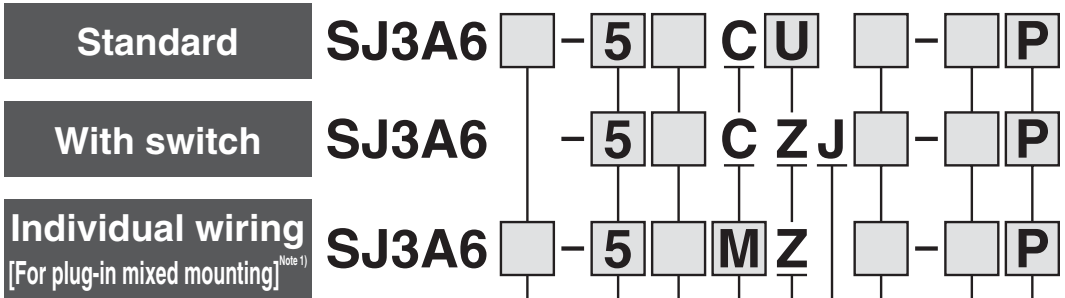

Note 1) Refer to pages 91 and 92 for the dedicated non plug-in individual wiring.

Coil spec.

—	Standard
T	With power saving circuit (Continuous duty type)

* Be sure to select "with power saving circuit" when the solenoid valve will be energised continuously for long period.

Rated voltage

5	24 VDC
6	12 VDC

* Only 24 VDC is available for manifolds compatible with serial wiring and PC wiring.

Common specifications

—	Positive common
N	Negative common

- * Only positive common is available for manifolds compatible with PC wiring.
- * For the non-polar type, there is no need to select a symbol.
- * When the manifold applicable to the serial transmission system and the valve with the standard type switch are used, select common specifications suitable for the SI unit common specifications.

Connector entry

C: Dedicated for centralised wiring

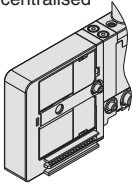

M: Individual wiring, With lead wire Length 300 mm

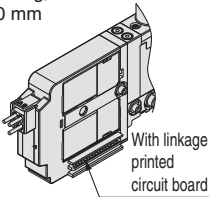

MN: Individual wiring, Without lead wire (With connector, socket)

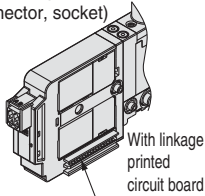

MO: Individual wiring, Without connector

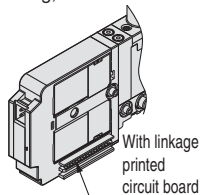

Light/surge voltage suppressor

U	With light/surge voltage suppressor (Non-polar type)
Z	With light/surge voltage suppressor (Polar type)

* When the types with power saving circuit, with switches, and/or individual wiring are used, the non-polar type cannot be selected.

With switch

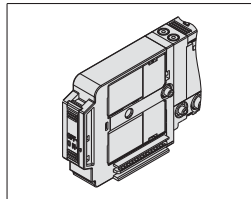

Needle operation

—: Manual

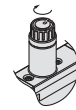

D: Slotted locking type



* Set operation torque to 0.3 N·m or less.

PS port for detection

—: M5 x 0.8

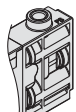

P: With plug (M-5P)



* When mounting a pressure sensor etc., select "—."

Manual override

—: Non-locking push type

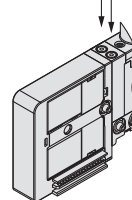

D: Push-turn locking slotted type

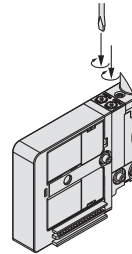

* No slide locking type manual override setting is provided.

Note 2) There is no valve block switch for linking the neighboring valve, etc. to the 3 position 3 port solenoid valve with restrictor. Consult SMC if you wish to use the SJ2000/3000 valve with a valve block switch, or an end block or SUP/EXH block assembly.

- * Connector entries with the symbol "M□" can not use the switch signal from the common wiring on the manifold.
- * When ordering a connector assembly separately, refer to pages 101 and 102.

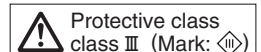

SJ 2000 3000 Common Specifications
 Construction
 Plug-in
 Connector Type/ Cable Type
 Non plug-in
 Individual Wiring
 Manifold Options
 Made to Order
 SJ3A6
 Common Specifications/ Construction
 Plug-in
 Connector Type/ Cable Type
 Non plug-in
 Individual Wiring

Plug-in Cable Type

Vacuum Release Valve with Restrictor

Series SJ3A6

An order cannot be placed with only the manifold part no. Be sure to order solenoid valves for mounting at the same time while referring to the ordering example.

How to Order

● Vacuum release valve manifold with restrictor

SS3J3-V60L **D** - **05** **U**

Vacuum release valve with restrictor type

Cable type

Connector type

Symbol	Mounting position	Page	Note
F	D-sub connector	P.17	Parallel wiring
P	Flat ribbon cable 26 pins		
PG	Flat ribbon cable 20 pins		
PH	Flat ribbon cable 10 pins		

Connector mounting position

Symbol	Mounting position
D	D side

Connector entry

With parallel wiring specifications, it is necessary to select the connector entry direction (1: upward, 2: lateral). For details, refer to page17.

● DIN rail length specified

—	Standard length
3	3 stations Specify a longer rail than the standard length.
⋮	⋮
10	10 stations

* When specifying a rail longer than the standard length, select the valve stations not exceeding the maximum stations.

● SUP/EXH block fitting spec.

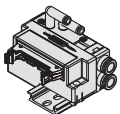
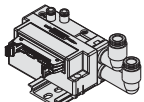
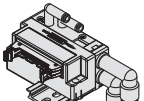
—	Straight fitting	
	X, PE port: elbow fitting	
L	Elbow fitting (Upward)	
	X, PE port: straight fitting	
B	Elbow fitting (Downward)	
	X, PE port: elbow fitting	

* There is no need to enter anything when the SUP/EXH block mounting position "M" is selected. Also, this manifold comes standard with external pilot specifications.

● SUP/EXH block mounting position

U	U side (2 to 10 stations)
D	D side (2 to 10 stations)
B	Both sides (2 to 10 stations)
M*	Special specifications

* For the special specifications, a port size of the SUP/EXH block assembly can be specified. At this time, the mounting position becomes only U, D, or B.

How to Order Valve Manifold Assembly

Ordering example (SS3J3-V60PD2-□)

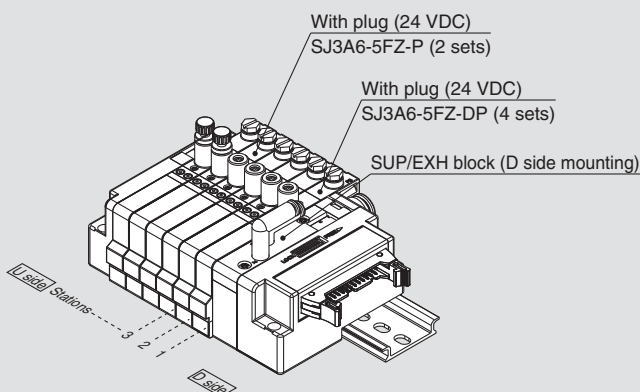

SS3J3-V60LPD2-06D ... 1 set (Manifold part no.)
 * **SJ3A6-5FZ-DP** 4 sets (With plug part no.)
 * **SJ3A6-5FZ-P** 2 sets (With plug part no.)
 → The asterisk denotes the symbol for assembly. Prefix to the part no. of the solenoid valve, etc.

- The valve arrangement is numbered as the 1st station from D side.
- Indicate the valves to be attached below the manifold part number, in order starting from station 1 as shown in the drawing. In the case of complex arrangement, specify them in the manifold specification sheet.

● Valve stations

F: D-sub connector

Symbol	Stations
02	2 stations
⋮	⋮
10	10 stations

P: Flat ribbon cable (26 pins)

Symbol	Stations
02	2 stations
⋮	⋮
10	10 stations

PG: Flat ribbon cable (20 pins)

Symbol	Stations
02	2 stations
⋮	⋮
09	9 stations

PH: Flat ribbon cable (10 pins)

Symbol	Stations
02	2 stations
⋮	⋮
04	4 stations

* The number of the blanking block assembly is also included.

* The cable type is applicable to 2 or more stations.

How to Order Solenoid Valves (3 Position 3 Port with Restrictor)

SJ3A6 - **5** **FZ** - **P**

Coil spec.

—	Standard
T	With power saving circuit (Continuous duty type)

* Be sure to select "with power saving circuit" when the solenoid valve will be energised continuously for long period.

Rated voltage

5	24 VDC
6	12 VDC

Common specifications

—	Positive common
N	Negative common

Connector entry

F: Dedicated for centralised wiring
Cable type

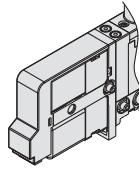

Light/surge voltage suppressor

Z	With light/surge voltage suppressor
----------	-------------------------------------

Manual override

—: Non-locking push type

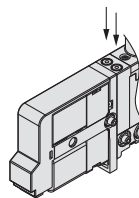

D: Push-turn locking
slotted type

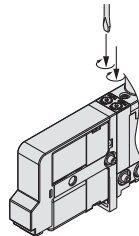

* No slide locking type manual override setting is provided.

PS port for detection

—: M5 x 0.8



P: With plug (M-5P)



* When mounting a pressure sensor etc., select "—."

Needle operation

—: Manual

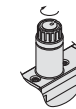

D: Slotted locking type

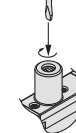

* Set operation torque to 0.3 N·m or less.

Note) There is no valve block switch for the 3 position 3 port solenoid valve with restrictor.

Protective class class III (Mark:)

Individual Wiring | **Non plug-in**

Connector Type/
Cable Type

Plug-in

Common Specifications/
Construction

SJ3A6

Made to Order

Manifold Options

Individual Wiring

Non plug-in

Connector Type/
Cable Type

Plug-in

Construction

Common Specifications



**SJ
2000
3000**

Non plug-in Individual Wiring Vacuum Release Valve with Restrictor Series **SJ3A6**

An order cannot be placed with only the manifold part no. Be sure to order solenoid valves for mounting at the same time while referring to the ordering example.

How to Order

● Individual wiring manifold

SS3J3-V60-05 U  

Vacuum release valve with restrictor type

Valve stations

Symbol	Stations
01	1 station
⋮	⋮
20	20 stations

* The number of the blanking block assembly is also included.

SUP/EXH block mounting position

U	U side (1 to 10 stations)
D	D side (1 to 10 stations)
B	Both sides (1 to 20 stations)
M*	Special specifications

* Specify the required specifications (Including port sizes other than ø8) by means of the manifold specification sheet.

DIN rail length specified

—	Standard length	Specify a longer rail than the standard length.
2	2 stations	
20	20 stations	

* Specify the valve stations not exceeding the maximum stations.

SUP/EXH block fitting spec.

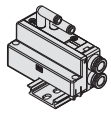
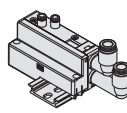
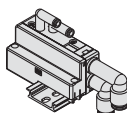
—	Straight fitting	
L	Elbow fitting (Upward)	
B	Elbow fitting (Downward)	

* There is no need to enter anything when the SUP/EXH block mounting position "M" is selected. Also, this manifold comes standard with external pilot specifications.

How to Order Manifold Assembly

Ordering example (SS3J3-V60-□)

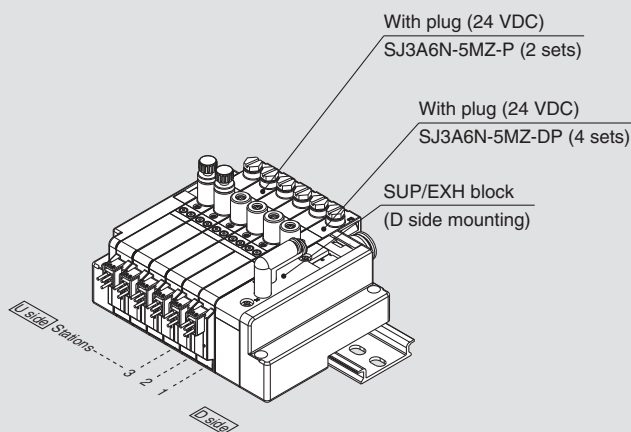

SS3J3-V60-06D 1 set (Manifold part no.)
 * **SJ3A6N-5MZ-DP** 4 sets (With plug part no.)
 * **SJ3A6N-5MZ-P** 2 sets (With plug part no.)

→ The asterisk denotes the symbol for assembly. Prefix to the part no. of the solenoid valve, etc.

- The valve arrangement is numbered as the 1st station from D side.
- Indicate the valves to be attached below the manifold part number, in order starting from station 1 as shown in the drawing. In the case of complex arrangement, specify them in the manifold specification sheet.

How to Order Solenoid Valves (3 Position 3 Port with Restrictor)

SJ3A6 **N-5** **MZ** **-** **P**

Coil spec.

—	Standard
T	With power saving circuit (Continuous duty type)

* Be sure to select "with power saving circuit" when the solenoid valve will be energised continuously for long period.

For non plug-in only

Rated voltage

5	24 VDC
6	12 VDC

Common specifications

—	Positive common
N	Negative common

Connector entry

M: Individual wiring, With lead wire
Length 300 mm

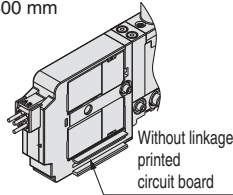

MN: Individual wiring, Without lead wire (With connector, socket)

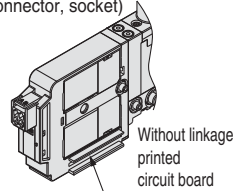

MO: Individual wiring, Without connector

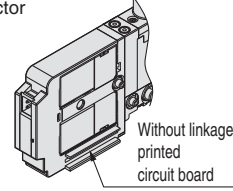

* When ordering a connector assembly separately, refer to pages 101 and 102.

With light/surge voltage suppressor

PS port for detection

—: M5 x 0.8



P: With plug (M-5P)

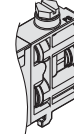

* When mounting a pressure sensor etc., select "—."

Needle operation

—: Manual



D: Slotted locking type



* Set operation torque to 0.3 N·m or less.

Manual override

—: Non-locking push type

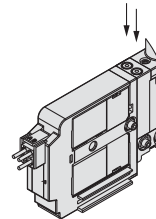

D: Push-turn locking slotted type

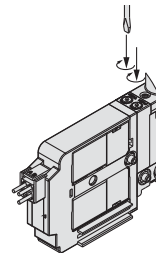

* No slide locking type manual override setting is provided.

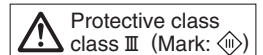

Series SJ3A6

Dimensions

SS3J3-V60-Stations U/D/B

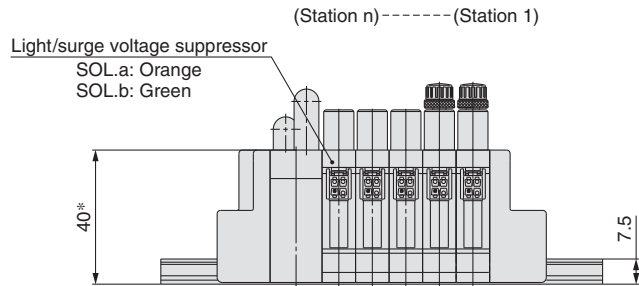

* Height to manual override
Push type manual override: 40.3
Locking type manual override: 40.5

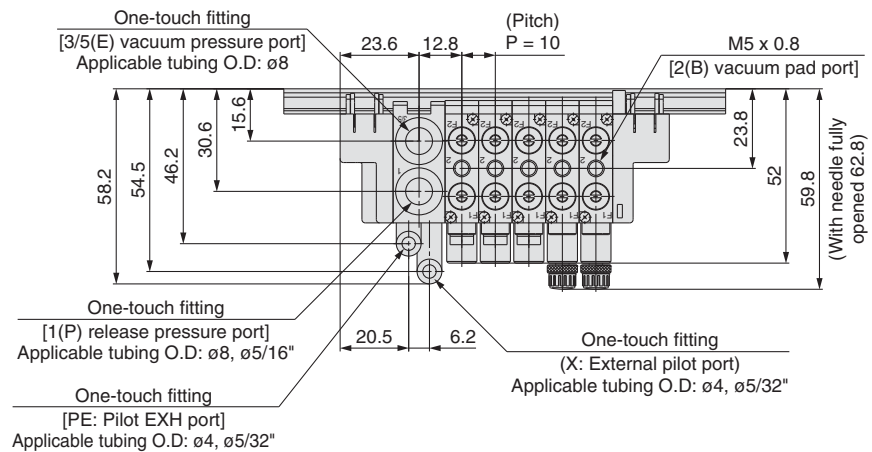
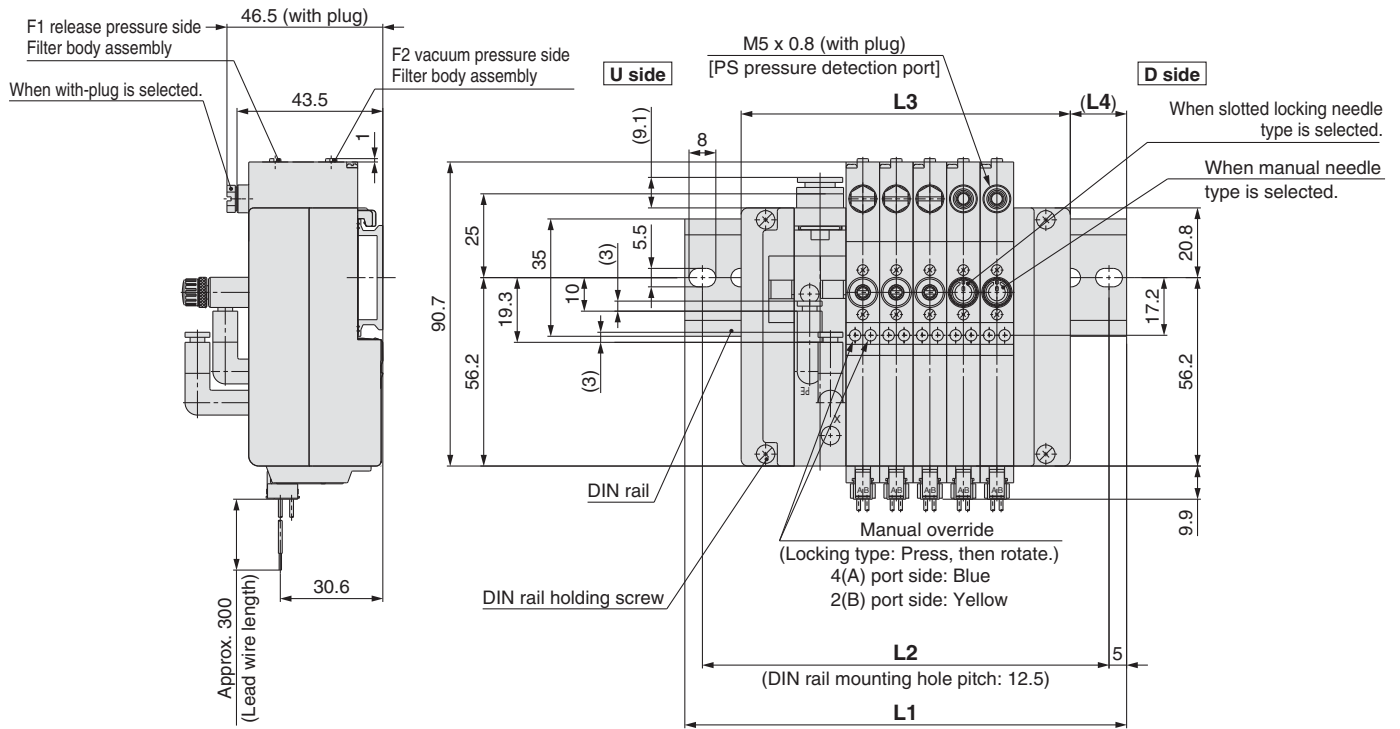

Since DIN rail dimensions are the same as the SS5J3-60-□ series, refer to pages 65 and 66.

Manifold Exploded View 1

Connector Type/Individual Wiring

Type V60P (Vacuum release valve with restrictor) manifold

Note) Refer to page 58 for "How to Increase Manifold Stations."

Type V60S (Plug-in, EX180 Integrated type (for output serial transmission system) manifold

Type V60G (Plug-in, PC wiring with power supply terminal) manifold

U side

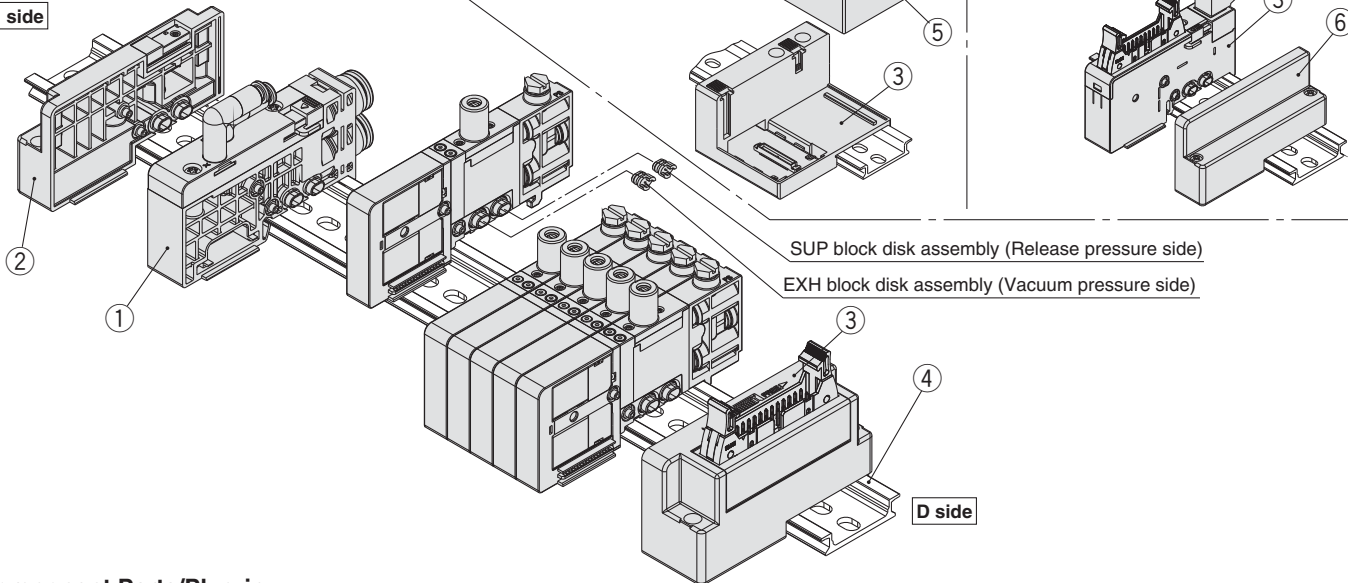

Component Parts/Plug-in

No.	Description	Part no.	Note
1 <small>Note 1)</small>	SUP/EXH block assembly	External pilot specification SJ3000-50-1AR-□□-N (X, PE port: Metric size ø4 Inch size ø5/32")	(Metric size) C6: With ø6 One-touch fitting (straight) C8: With ø8 One-touch fitting (straight) L6: With ø6 One-touch fitting (elbow upward entry) L8: With ø8 One-touch fitting (elbow upward entry) B6: With ø6 One-touch fitting (elbow downward entry) B8: With ø8 One-touch fitting (elbow downward entry)
		For different pressures <small>Note 2)</small> SJ3000-50-3A-□□-N	(Inch size) N7: With 1/4" One-touch fitting (straight) N9: With 5/16" One-touch fitting (straight)
2 <small>Note 1)</small>	End block assembly	SJ3000-53-1A-N	For U side
3	Connector block assembly	SJ3000-42-□A-□ SJ3000-76-2A-05	Refer to the connector block assembly part no. shown below.
4	DIN rail	VZ1000-11-1-□	Refer to page 71.
5	SI unit	EX180-□□	Refer to the SI unit part numbers on page 41.
6	End block assembly	SJ3000-53-2A	For D side

Connector Block Assembly Part No.

Connector specifications	Mounting position	Part no.	Note
For D-sub connector (Locking bracket: Metric size thread)	D side	SJ3000-42-1A-□	□: 1 (Connector upward) □: 2 (Connector lateral)
For D-sub connector (Locking bracket: Unified thread)		SJ3000-42-1AU-□	
For flat ribbon cable 26 pins		SJ3000-42-2A-□	
For flat ribbon cable 20 pins		SJ3000-42-3A-□	
For flat ribbon cable 10 pins		SJ3000-42-4A-□	
For PC wiring 20 pins		SJ3000-42-6A-□	
For EX180 serial wiring <small>Note)</small>		SJ3000-42-20A	
For EX510 serial wiring <small>Note)</small>		SJ3000-42-3A-2	
For PC wiring 20 pins with power supply terminal		SJ3000-76-2A-05	

Note) SI unit is not included.

Component Parts/Non plug-in (Individual Wiring)

No.	Description	Part no.	Note
1 <small>Note 1)</small>	SUP/EXH block assembly	External pilot specification SJ3000-50-5AR-□□-N (X, PE port: Metric size ø4 Inch size ø5/32")	(Metric size) C6: With ø6 One-touch fitting (straight) C8: With ø8 One-touch fitting (straight) L6: With ø6 One-touch fitting (elbow upward entry) L8: With ø8 One-touch fitting (elbow upward entry) B6: With ø6 One-touch fitting (elbow downward entry) B8: With ø8 One-touch fitting (elbow downward entry)
		For different pressures <small>Note 2)</small> SJ3000-50-6A-□□-N	(Inch size) N7: With 1/4" One-touch fitting (straight) N9: With 5/16" One-touch fitting (straight)
2 <small>Note 1)</small>	End block assembly	SJ3000-53-1A-N	For U side
4	DIN rail	VZ1000-11-1-□	Refer to page 71.
6	End block assembly	SJ3000-53-2A	For D side

Note 1) For the SJ3A6 series, valve block and manual switches are not available.

Note 2) The valves cannot be operated only with the SUP/EXH block assembly for different pressure, select in combination with the SUP/EXH block assembly for external pilot.

Note 3) Refer to page 69 about the SUP/EXH block disk assembly and method of handling of parts at different pressure.

Series SJ3A6

Manifold Exploded View 2

Cable Type

Type V60LP (Vacuum release valve with restrictor) manifold

Note) Refer to page 59 for "How to Increase Manifold Stations."

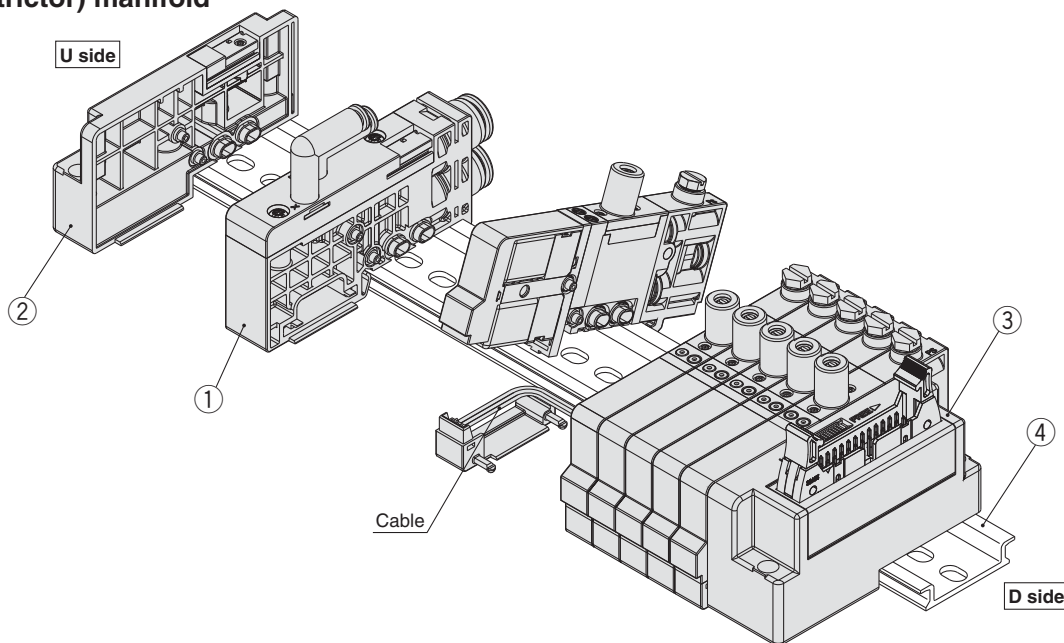

Component Parts/Plug-in (Cable Type)

No.	Description	Part no.	Note
1 ^{Note 1)}	SUP/EXH block assembly	External pilot specification	(Metric size) C6: With ø6 One-touch fitting (straight) C8: With ø8 One-touch fitting (straight) L6: With ø6 One-touch fitting (elbow upward entry) L8: With ø8 One-touch fitting (elbow upward entry) B6: With ø6 One-touch fitting (elbow downward entry) B8: With ø8 One-touch fitting (elbow downward entry) (Inch size) N7: 1/4" One-touch fitting (straight) N9: 5/16" One-touch fitting (straight)
		For different pressures ^{Note 2)}	
2 ^{Note 1)}	End block assembly	SJ3000-53-1A-N	
3	Connector block assembly	SJ3000-42-□A-□	Refer to the connector block assembly part no. shown below.
4	DIN rail	VZ1000-11-1-□	Refer to page 71.

Note 1) For the SJ3A6 series, valve block and manual switches are not available.

Note 2) The valves cannot be operated only with the SUP/EXH block assembly for different pressure, select in combination with the SUP/EXH block assembly for external pilot.

Note 3) Refer to page 69 about the SUP/EXH block disk assembly and method of handling of parts at different pressure.

●Connector Block Assembly

SJ3000-42-□ A □ - □ - 05

Connector type

7	D-sub connector
8	Flat ribbon cable 26 pins
9	Flat ribbon cable 20 pins
10	Flat ribbon cable 10 pins

* All connector block assembly mounting positions become the D side.

* The connector block assembly includes the cables necessary for the number of stations.

Valve stations

02 to 10	D-sub connector
02 to 10	Flat ribbon cable 26 pins
02 to 09	Flat ribbon cable 20 pins
02 to 04	Flat ribbon cable 10 pins

Connector entry

1	Connector upward
2	Connector lateral

Locking bracket

—	Metric size thread
U	Unified thread

* D-sub connector only.



Series SJ2000/3000

Specific Product Precautions 1

Be sure to read before handling.

Refer to back cover for Safety Instructions and "Handling Precautions for SMC Products" (M-E03-3) for 3/4/5 Port Solenoid Valve Precautions.

Manual Override Switch Operation

Warning

For manual override operation, move the manual override switch to a position where letters A and B can be seen. [Manual override switch release status (refer to the figure below)] Operation with the manual override switch in a locked status can cause damage to the manual override and air leakage, so be sure to release the manual override switch before use. After manual override operation, lock the manual switch for use (when the manual override of the push-turn locking slotted type is locked, a manual override switch cannot be locked).

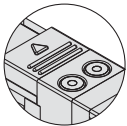

Manual override switch locked status

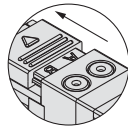

Manual override switch unlocked status

Manual override switch slide direction

Manual Override Operation

Warning

When the manual override is operated, connected equipment will be actuated. Confirm safety before operating.

Non-locking push type

Press in the direction of the arrow.

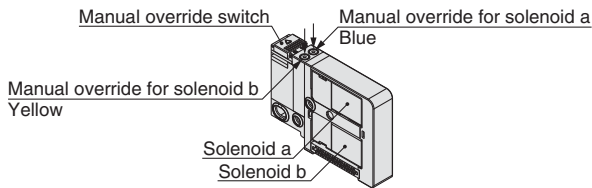

Push-turn locking slotted type

While pressing, turn in the direction of the arrow (90° clockwise). If it is not turned, it can be used in the same way as the non-locking push type.

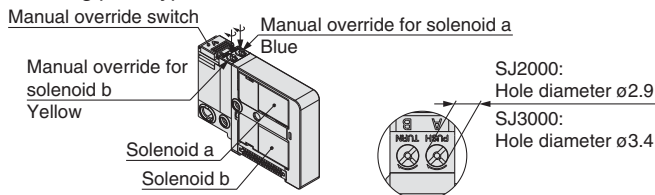

Enlarged view of manual override part

Slide locking type (manual override)

Slide the manual override all the way to the ON side in the arrow direction. The manual override is then locked. To unlock the manual override, slide it toward the OFF side in the arrow direction.

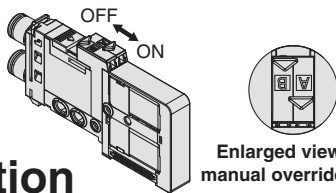

Enlarged view of manual override part

Caution

When you operate the D type with a screw driver, turn it gently using a watchmaker's screw driver. [Torque: under 0.05 N·m] When you lock the manual override of the D type, be sure to push it before turning. [Load: 10 N or less] Turning without pushing can cause damage to the manual override and trouble such as air leakage, etc.

Valve with Switch

Warning

When turning OFF the valve using the switch, move it to the position where the valve is locked. If the switch is at an improper position and is energised, equipment connected to the valve could be actuated.

Also, if the switch is turned OFF on the valve in the energised state, be careful because any actuators connected to a single solenoid, a dual 3 port valve or a 3 position valve will actuate.

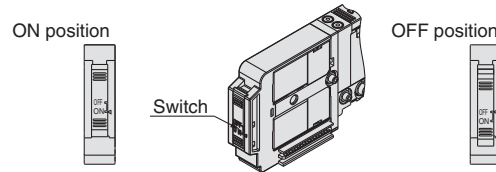

Normal operation: The valve is switched according to electric signals from the connector on the manifold side.

The valve coil is kept in a deenergised state even when there is an electric signal from the connector on the manifold side.

Electric circuit diagram

(with positive common and light/surge voltage suppressor)

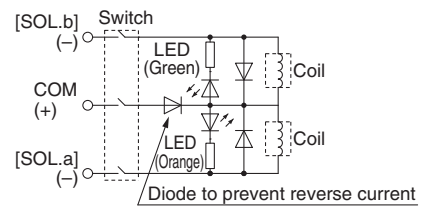

(with negative common and light/surge voltage suppressor)

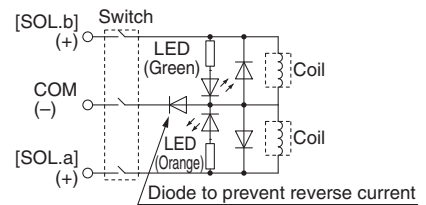

Built-in Back Pressure Check Valve Type

Caution

Valves with built-in back pressure check valve is to protect the back pressure inside a valve. For this reason, use caution the valves with external pilot specification cannot be pressurised from exhaust port [3/5(E)].

As compared with the types which do not integrate the back pressure check valve, C value of the flow characteristics (sonic conductance) goes down. For details, please contact SMC.

Exhaust Restriction

Caution

Since the SJ series is a type in which the pilot valve exhaust joins the main valve exhaust inside the valve, use caution, so that the piping from the exhaust port is not restricted.

Series SJ2000/3000

Specific Product Precautions 2



Be sure to read before handling.

Refer to back cover for Safety Instructions and "Handling Precautions for SMC Products" (M-E03-3) for 3/4/5 Port Solenoid Valve Precautions.

When Using a 4 Port Valve as a 3 Port Valve

Caution

When using a 4 port valve as a 3 port valve

The SJ2000/3000 series can be used as normally closed (N.C.) or normally open (N.O.) 3 port valves by plugging one of the cylinder ports 4(A) or 2(B). However, exhaust ports should be left open. It is convenient when a double solenoid 3 port valve is required.

Plug position	2(B) port	4(A) port
Type of actuation	N.C.	N.O.
Number of solenoids	Single (A)4 2(B) (EA)5 1 3(EB) (P)	Single (A)4 2(B) (EA)5 1 3(EB) (P)
	Double (A)4 2(B) (EA)5 1 3(EB) (P)	Double (A)4 2(B) (EA)5 1 3(EB) (P)

Light/Surge Voltage Suppressor

Caution

Non-polar type Single solenoid

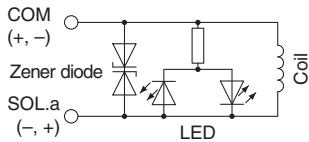

Double solenoid, 3 position type

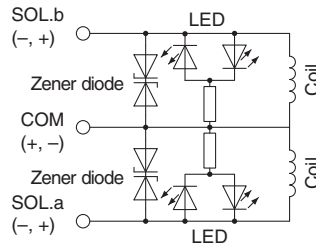

Positive common Single solenoid

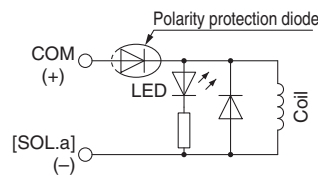

Double solenoid, 3 position type

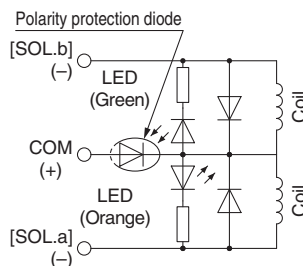

Negative common Single solenoid

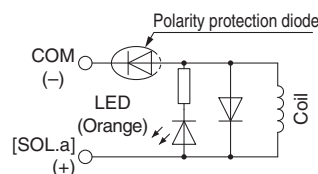

Double solenoid, 3 position type

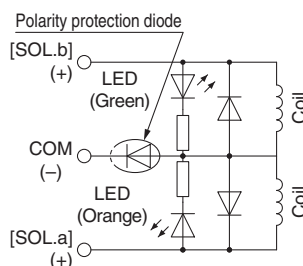

Continuous Duty

Caution

If a valve is energised continuously for a long time, the rise in temperature due to heat-up of the coil may cause a decline in solenoid valve performance, reduce service life, or have adverse effects on peripheral equipment. If a valve will be energised continuously, please be sure to use the "Continuous duty type" with a power saving circuit. In particular, there will be a large increase in temperature if 3 or more neighbouring stations are simultaneously continuously energised for a long time, or if the A and B sides are simultaneously continuously energised for a long time in a dual 3 port valve. Please be very careful in such cases. If the continuously energised time exceeds three hours, contact SMC.

With power saving circuit

Compared to the standard products, power consumption is reduced down to approx. 1/3 (in case of SJ3□60T) by cutting the unnecessary wattage required to hold the valve in an energised state. (Effective energizing time is over 67 ms at 24 VDC.)

Electric circuit diagram (with power saving circuit) In case of positive common, single solenoid

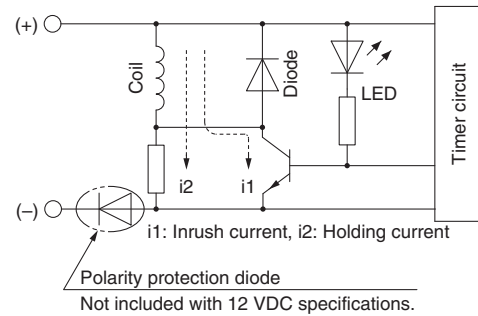

In case of negative common, single solenoid

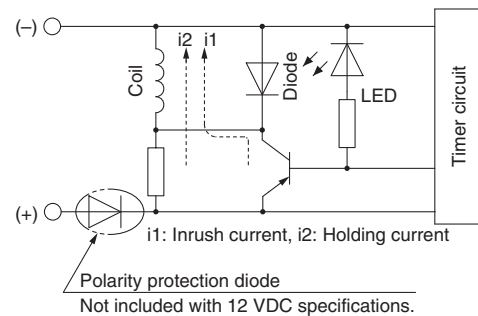



Series SJ2000/3000

Specific Product Precautions 3

Be sure to read before handling.

Refer to back cover for Safety Instructions and "Handling Precautions for SMC Products" (M-E03-3) for 3/4/5 Port Solenoid Valve Precautions.

Working Principle

With the circuit of page 93, the current consumption, when holding, is reduced to save energy. Please refer to the electric wave form data below.

In case of SJ3□60T, electric waveform of energy saving type

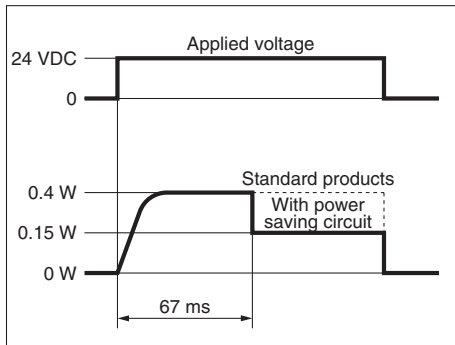

- When a power saving circuit is installed, a diode to prevent reverse current is not available for 12 VDC spec. Therefore, use caution not to connect in reverse.
- Be careful about the allowable voltage fluctuation since a voltage drop of about 0.5 V occurs due to a transistor. (Refer to the solenoid specifications of each valve for details.)

Measures to prevent detours of surge voltage

When the DC power supply is shut off, by the emergency breaking circuit for example, valve misoperation may occur due to surge voltage produced by other electrical parts (such as electromagnetic coils). Please take measures to prevent surges from detouring to the valve (surge protection diode etc.), or use a valve with diode to prevent reverse current (polar: Z type). However, surge countermeasures are provided on the serial unit side of the serial type.

Circuit example

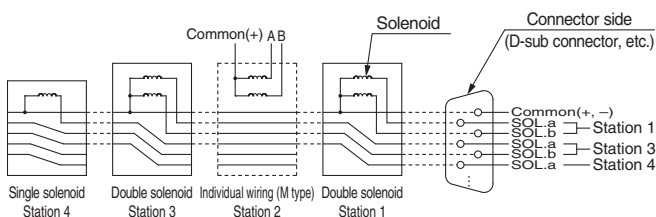

Light Indication

Caution

When equipped with light/surge voltage suppressor, the light window turns orange when solenoid a is energised, and it turns green when solenoid b is energised.

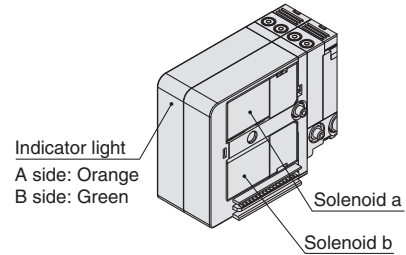

Changing the Connector Entry Direction

Caution

To change the connector's entry direction, set the switch on the top of the connector block to the FREE position, before turning the connector. Make sure to set the switch back to the LOCK position before connecting the connector. (When the switch is difficult to slide, move the connector a little so that it will slide easier.) If an excessive force is applied on the connector in the LOCK position, the connector block may be damaged. Also, using in such a way that the connector floats in the FREE position, it may cause the lead wire, etc. to break. Thus, refrain from using in these ways.

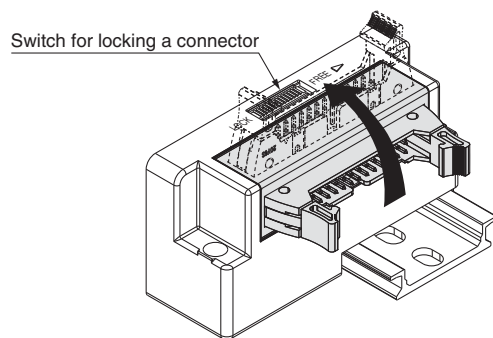

Manifold Mounting

When attaching a manifold to a mounting surface, etc., with bolts, if the entire bottom surface of the DIN rail contacts the mounting surface in a horizontal mounting, it can be used by simply securing both ends of the DIN rail. However, for any other mounting method or for side facing and rear facing, etc., secure the DIN rail with bolts at uniform intervals using the following as a guide: 2 to 5 stations at 2 locations, 6 to 10 stations at 3 locations, 11 to 15 stations at 4 locations, 16 to 20 stations at 5 locations, 21 to 25 stations at 6 locations, 26 to 30 stations at 7 locations and more than 30 stations at 8 locations.

In addition, even in the case of a horizontal mounting, if the mounting surface is subject to vibration, etc., take the same measures indicated above. If secured at fewer than the specified number of locations, warping or twisting may occur in the DIN rail and manifold, causing trouble such as air leakage.



Series SJ2000/3000

Specific Product Precautions 4

Be sure to read before handling.

Refer to back cover for Safety Instructions and "Handling Precautions for SMC Products" (M-E03-3) for 3/4/5 Port Solenoid Valve Precautions.

Fitting Replacement

Caution

By replacing a valve's fitting assembly, it is possible to change the port size of the 4(A), 2(B), 1(P), and 3/5(E) ports. When replacing it, pull out the fitting assembly after removing the clip with a flat brade screw driver, etc. To mount a new fitting assembly, insert it into place and then fully reinsert the clip.

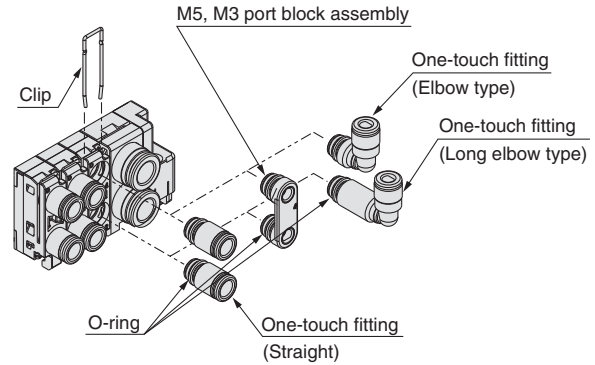

Fitting Assembly Part No.

Metric Size

Port	Port size	Part no.
SJ2000 4(A) 2(B)	ø2 One-touch fitting (Straight)	KJH02-C1
	ø4 One-touch fitting (Straight)	KJH04-C1
	ø2 One-touch fitting (Elbow type)	KJL02-C1
	ø4 One-touch fitting (Elbow type)	KJL04-C1-N
	ø2 One-touch fitting (Long elbow type)	KJW02-C1
	ø4 One-touch fitting (Long elbow type)	KJW04-C1-N
	M3 port block assembly	SJ2000-56-1A
SJ3000 4(A) 2(B)	ø2 One-touch fitting (Straight)	KJH02-C2
	ø4 One-touch fitting (Straight)	KJH04-C2
	ø6 One-touch fitting (Straight)	KJH06-C2
	ø2 One-touch fitting (Elbow type)	KJL02-C2
	ø4 One-touch fitting (Elbow type)	KJL04-C2
	ø6 One-touch fitting (Elbow type)	KJL06-C2-N
	ø2 One-touch fitting (Long elbow type)	KJW02-C2
	ø4 One-touch fitting (Long elbow type)	KJW04-C2
	ø6 One-touch fitting (Long elbow type)	KJW06-C2-N
	M5 port block assembly	SJ3000-56-1A
	1(P) 3/5(E)	ø6 One-touch fitting (Straight)
ø6 One-touch fitting (Elbow type)		SZ3000-74-1A-L6
ø6 One-touch fitting (Long elbow type)		SZ3000-74-2A-L6
ø8 One-touch fitting (Straight)		VVQ1000-51A-C8
ø8 One-touch fitting (Long elbow type)		SZ3000-74-1A-L8

Inch Size

Port	Port size	Part no.
SJ2000 4(A) 2(B)	ø1/8" One-touch fitting (Straight)	KJH01-C1
	ø5/32" One-touch fitting (Straight)	KJH03-C1
	ø1/8" One-touch fitting (Elbow type)	KJL01-C1
	ø5/32" One-touch fitting (Elbow type)	KJL03-C1
	ø1/8" One-touch fitting (Long elbow type)	KJW01-C1
	ø5/32" One-touch fitting (Long elbow type)	KJW03-C1
SJ3000 4(A) 2(B)	ø1/8" One-touch fitting (Straight)	KJH01-C2
	ø5/32" One-touch fitting (Straight)	KJH03-C2
	ø1/4" One-touch fitting (Straight)	KJH07-C2
	ø1/8" One-touch fitting (Elbow type)	KJL01-C2
	ø5/32" One-touch fitting (Elbow type)	KJL03-C2
	ø1/4" One-touch fitting (Elbow type)	KJL07-C2
	ø1/8" One-touch fitting (Long elbow type)	KJW01-C2
	ø5/32" One-touch fitting (Long elbow type)	KJW03-C2
1(P) 3/5(E)	ø1/4" One-touch fitting (Straight)	VVQ1000-51A-N7
	ø5/16" One-touch fitting (Straight)	VVQ1000-51A-N9

Note 1) To change the port size of the 1(P), 3/5(E) ports into the port sizes other than ø8 (straight), specify the change by means of the manifold specification sheet.

Note 2) Be careful to avoid damage or contamination to the O-rings, as this can cause air leakage.

Note 3) When removing a straight-type fitting from a valve, after removing the clip, attach tubing or a plug (KJP-02, KQ2P-□□) to the One-touch fitting, and pull it out while holding the tubing or plug. If it is pulled out while holding the release button of the fitting (resin part), the release button may be damaged.

Note 4) Be sure to turn off the power and stop the supply of air before disassembly. Furthermore, since air may remain inside the actuator, piping and manifold, confirm that the air is completely exhausted before starting any work.

Note 5) While inserting a tubing into an elbow-type fitting, hold the main body of the fitting by hand. Failure to do so will exert an undue force on the valve or the fitting, resulting in air leakage or damage.

Note 6) Each fitting assembly part no. contains 1 pc. Additionally, when the piping is constructed in the same direction using the elbow-type fitting, order the elbow-type and/or long elbow-type fitting.

Clip Part No.

Part no.		Note
SJ2000	SJ3000	
SJ2000-CL-1	SJ3000-CL-1	These part numbers contain 10 pcs. each.

O-ring for Valve Connection (Common to SJ2000/3000)

Part no.	Note
SJ3000-96-1A	The part numbers shown on the left includes parts for 5 units. (10 pcs. each for P, E port and X port)

Specific Product Precautions 5



Be sure to read before handling.

Refer to back cover for Safety Instructions and "Handling Precautions for SMC Products" (M-E03-3) for 3/4/5 Port Solenoid Valve Precautions.

One-touch Fittings

⚠ Caution

The pitch of the SJ series piping ports (A, B etc.) has been set assuming the use of KJ series One-touch fittings. Therefore, when using fittings with an M3 or M5 port block assembly, there may be some interference between fittings, depending on the type and size, so please use after checking dimensions in the catalogue for the pipe fitting being used.

1. Tube attachment/detachment for One-touch fittings

1) Tube attachment

- (1) Take a tube having no flaws on its periphery and cut it off at a right angle. When cutting the tube, use tube cutters TK-1, 2 or 3. Do not use pinchers, nippers or scissors, etc. If cutting is done with tools other than tube cutters, the tube may be cut diagonally or become flattened, etc., making a secure installation impossible, and causing problems such as the tube pulling out after installation or air leakage.

Also allow some extra length in the tube.

- (2) Grasp the tube and push it in slowly, inserting it securely all the way into the fitting.
- (3) After inserting the tube, pull on it lightly to confirm that it will not come out. If it is not installed securely all the way into the fitting, this can cause problems such as air leakage or the tube pulling out.

2) Tube detachment

- (1) The 4(A) and 2(B) ports use the KJ series, so the tube can be removed by pressing on part of the release bush. However, for the 1(P) and 3/5(E) ports, please press the release bush evenly as before.
- (2) Pull out the tube while holding down the release button so that it does not come out. If the release button is not pressed down sufficiently, there will be increased bite on the tube and it will become more difficult to pull it out.
- (3) When the removed tube is to be used again, cut off the portion which has been chewed before reusing it. If the chewed portion of the tube is used as is, this can cause trouble such as air leakage or difficulty in removing the tube.

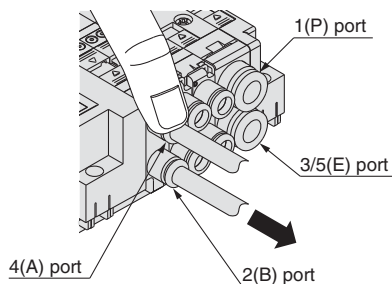

Hold down part of the release bush with your finger or a similar tool, as shown in the diagram, and pull out in the direction indicated by the arrow.

Other Tube Brands

⚠ Caution

1. When using other than SMC brand tube, confirm that the following specifications are satisfied with respect to the tube outside diameter tolerance.

- 1) Nylon tube within ± 0.1 mm
- 2) Soft nylon tube within ± 0.1 mm
- 3) Polyurethane tube within $+0.15$ mm, within -0.2 mm

Do not use tube which does not meet these outside diameter tolerances. It may not be possible to connect them, or they may cause other trouble, such as air leakage or the tube pulling out after connection.

How to Use Plug Connector

⚠ Caution

When attaching and detaching a connector, first shut off the electric power and the air supply.

Also, crimp the lead wires and sockets securely.

1. Connector attachment/detachment

- To attach a connector, hold the lever and connector unit between your fingers and insert straight onto the pins of the solenoid valve so that the lever's pawl is pushed into the groove and locks.
- To detach a connector, remove the pawl from the groove by pushing the lever downward with your thumb, and pull the connector straight out.

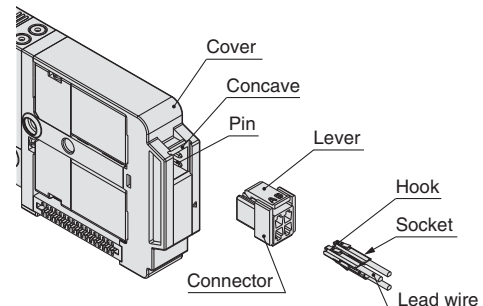

2. Crimping of lead wires and sockets

Peel 3.2 to 3.7 mm of the tip of lead wire, enter the core wires neatly into a socket and crimp it with a special crimp tool. Be careful so that the cover of lead wire does not enter into the crimping part. (Crimping tool: Model no. DXT170-75-1)

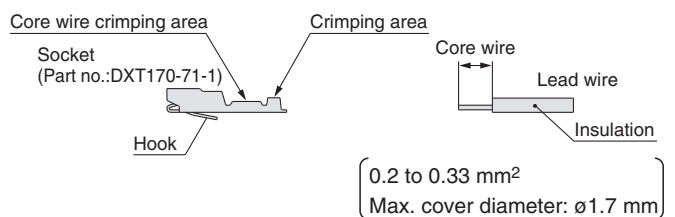



Series SJ2000/3000

Specific Product Precautions 6

Be sure to read before handling.

Refer to back cover for Safety Instructions and "Handling Precautions for SMC Products" (M-E03-3) for 3/4/5 Port Solenoid Valve Precautions.

How to Use Plug Connector

⚠ Caution

3. Lead wires with sockets attachment/detachment

• Attachment

Insert the sockets into the square holes of the connector (with A, B, C, and N indication), and continue to push the sockets all the way in until the lock by hooking into the seats in the connector. (When they are pushed in, their hooks open and they are locked automatically.) Next, confirm that they are locked by pulling lightly on the lead wires.

• Detachment

To detach a socket from a connector, pull out the lead wire while pressing the socket's hook with a stick having a thin tip (approx. 1 mm). If the socket is used again, spread the hook outward.

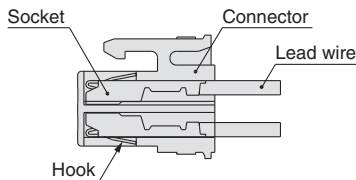

<Positive common>

Single solenoid

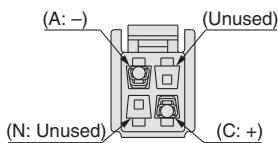

Double solenoid

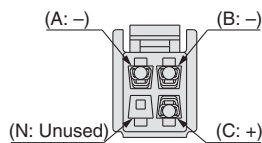

<Negative common>

Single solenoid

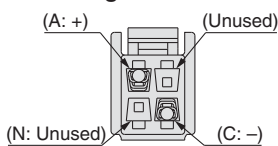

Double solenoid

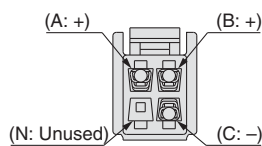

Plug Connector Lead Wire Length

⚠ Caution

Plug connector lead wires have a standard length of 300 mm, however, the following lengths are also available.

Connector Assembly Part No.

Single solenoid

SJ3000-46-S-□ (for positive common)

SJ3000-47-S-□ (for negative common)

Double solenoid, 3 position type, 4 position type

SJ3000-46-D-□ (for positive common)

SJ3000-47-D-□ (for negative common)

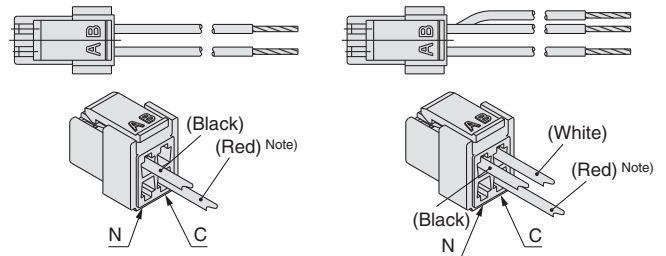

Note) In case of negative common, the lead wire changes from red to yellow.

		●Lead wire length	
For single solenoid:	SJ3000-46-S-□	—	300 mm
		6	600 mm
		10	1000 mm
For double solenoid		15	1500 mm
For 3 position type :	SJ3000-46-D-□	20	2000 mm
For 4 position type		25	2500 mm
		30	3000 mm
		50	5000 mm

Common specifications ●	
46	For positive common
47	For negative common

For single solenoid

Without lead wire : SJ3000-46-S-N (positive/negative common)
(Connector, Socket x 2 pcs. only)

For double solenoid

Without lead wire : SJ3000-46-D-N (positive/negative common)
(Connector, Socket x 3 pcs. only)

How to Order

Include the connector assembly part number together with the part number for the plug connector's solenoid valve without connector.

(Example) In case of lead wire length 2000 mm and positive common
SJ3160-5MOZ-C6
SJ3000-46-S-20

Connector Assembly for Manifolds (for Junction Common)

⚠ Caution

Using the connector assembly (for junction common) for solenoid valves installed in the manifold reduces the labor involved in wiring work because common wiring for all solenoid valves is integrated into a single wire.



Series SJ2000/3000

Specific Product Precautions 7

Be sure to read before handling.

Refer to back cover for Safety Instructions and "Handling Precautions for SMC Products" (M-E03-3) for 3/4/5 Port Solenoid Valve Precautions.

Connector Assembly Part No. (for Junction Common)

Single solenoid

SJ3000-46-SC-□ (for positive common)

SJ3000-47-SC-□ (for negative common)

Double solenoid,
3 position type, 4 position type

SJ3000-46-DC-□ (for positive common)

SJ3000-47-DC-□ (for negative common)

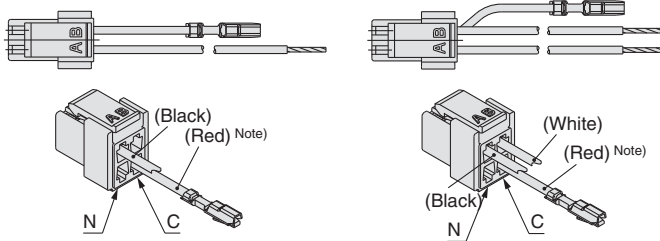

Note) In case of negative common, the lead wire changes from red to yellow.

For single solenoid:		SJ3000-46-SC-□		●Lead wire length	
		—	300 mm		
		6	600 mm		
		10	1000 mm		
		15	1500 mm		
		20	2000 mm		
		25	2500 mm		
		30	3000 mm		
		50	5000 mm		

For double solenoid		SJ3000-46-DC-□	
		—	300 mm
		6	600 mm
		10	1000 mm
		15	1500 mm
		20	2000 mm
		25	2500 mm
		30	3000 mm
		50	5000 mm

Common specifications	
46	For positive common
47	For negative common

● For junction common

How to Order

Indicate the part no. of the connector assembly for the manifold and solenoid valve.

If the arrangement is complicated, please specify them by means of the manifold specification sheet.

Note 1) Applications like connectors not wired to a valve is not possible.

Note 2) For the solenoid valve, please designate "No connector (MOZ)" for the connector type.

Note 3) Connector assembly with lead wire for place where the signals are transmitted to the common wiring. (Only the valves of first station and/or last station of manifold are compatible to connector with lead wire for common.)

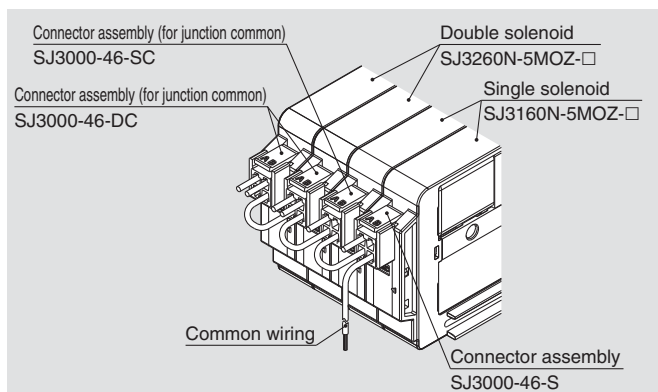

(Example)

- SS5J3-60-04U 1set
- * SJ3160N-5MOZ-C6 2set
- * SJ3260N-5MOZ-C6 2set
- * SJ3000-46-S 1set (Connector assembly for single solenoid)
- * SJ3000-46-SC 1set (Connector assembly for single solenoid) (for junction common)
- * SJ3000-46-DC 2set (Connector assembly for double solenoid) (for junction common)

The asterisk denotes the symbol for assembly. Prefix it to the part nos. of the solenoid valve, etc.

Wiring Instructions for Connector Assembly (for Junction Common)

Caution

If only connector assembly (for junction common) is ordered, please wire according to the instructions in the diagram below. For details on socket mounting, please refer to "How to Use Plug Connector" on page 100.

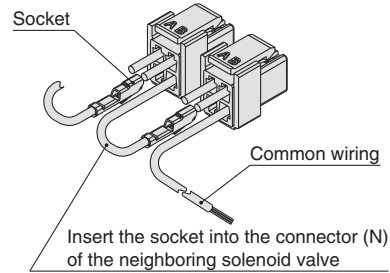

How to Wire to PC Wiring System Compliant Power Supply Terminal

Caution

Wire connection instructions

- Strip 6.5 to 7.5 mm from the tip of the lead wire.
- Loosen the terminal screws (slotted head screws) of the power supply terminal connectors, plug the core wire of the lead wire into the square holes of the connector, tighten terminal screws at the proper torque, and fasten them securely. (Gently pull the lead wire and check that it is fastened.)

Precautions

- To remove the power supply terminal connector, pull it upward as is. When mounting, push it in until it makes a snapping noise.
- When connecting wire, be careful because using lead wire that is outside of compatible lead wire ranges, or that are tightened to anything other than the proper torque, creates a risk of defective contact and other problems.

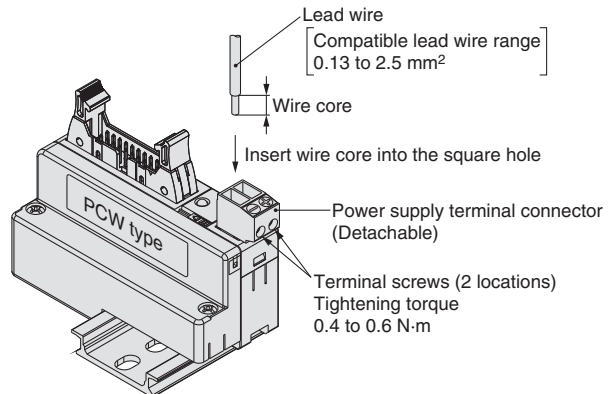



Series SJ2000/3000

Specific Product Precautions 8

Be sure to read before handling.

Refer to back cover for Safety Instructions and "Handling Precautions for SMC Products" (M-E03-3) for 3/4/5 Port Solenoid Valve Precautions.

One-touch Fittings

Caution

When fittings are used, they may interfere with one another depending on their types and sizes. Therefore, the dimensions of the fittings to be used should first be confirmed in their respective catalogues.

Fittings whose compliance with the SJ series is already confirmed are stated below. If the fitting within the applicable range is selected, there will not be any interference.

Applicable Fittings: Series KQ2H, KQ2S

Series KJH, KJS

Series	Model	Piping port	Port size	Fitting	Applicable tubing O.D.			
					ø2	ø3.2	ø4	ø6
SJ3000 (10 mm pitch)	SJ3□60-□□-M5	4A, 2B	M5	KQ2H KJH	[Redacted]			
				KQ2S KJS	[Redacted]			
SJ2000 (7.5 mm pitch)	SJ2□60-□□-M3	4A, 2B	M3	KQ2H KJH	[Redacted]			
				KQ2S KJS	[Redacted]			
SJ3A6 (10 mm pitch)	SJ3A6-□□	2B	M5	KQ2H KJH	[Redacted]			
				KQ2S KJS	[Redacted]			

Safety Instructions

These safety instructions are intended to prevent hazardous situations and/or equipment damage. These instructions indicate the level of potential hazard with the labels of “**Caution**,” “**Warning**” or “**Danger**.” They are all important notes for safety and must be followed in addition to International Standards (ISO/IEC)*1), and other safety regulations.

 **Caution:** **Caution** indicates a hazard with a low level of risk which, if not avoided, could result in minor or moderate injury.

 **Warning:** **Warning** indicates a hazard with a medium level of risk which, if not avoided, could result in death or serious injury.

 **Danger:** **Danger** indicates a hazard with a high level of risk which, if not avoided, will result in death or serious injury.

*1) ISO 4414: Pneumatic fluid power – General rules relating to systems.
ISO 4413: Hydraulic fluid power – General rules relating to systems.
IEC 60204-1: Safety of machinery – Electrical equipment of machines.
(Part 1: General requirements)
ISO 10218-1: Manipulating industrial robots - Safety.
etc.

Warning

1. The compatibility of the product is the responsibility of the person who designs the equipment or decides its specifications.

Since the product specified here is used under various operating conditions, its compatibility with specific equipment must be decided by the person who designs the equipment or decides its specifications based on necessary analysis and test results. The expected performance and safety assurance of the equipment will be the responsibility of the person who has determined its compatibility with the product. This person should also continuously review all specifications of the product referring to its latest catalogue information, with a view to giving due consideration to any possibility of equipment failure when configuring the equipment.

2. Only personnel with appropriate training should operate machinery and equipment.

The product specified here may become unsafe if handled incorrectly. The assembly, operation and maintenance of machines or equipment including our products must be performed by an operator who is appropriately trained and experienced.

3. Do not service or attempt to remove product and machinery/equipment until safety is confirmed.

1. The inspection and maintenance of machinery/equipment should only be performed after measures to prevent falling or runaway of the driven objects have been confirmed.
2. When the product is to be removed, confirm that the safety measures as mentioned above are implemented and the power from any appropriate source is cut, and read and understand the specific product precautions of all relevant products carefully.
3. Before machinery/equipment is restarted, take measures to prevent unexpected operation and malfunction.

4. Contact SMC beforehand and take special consideration of safety measures if the product is to be used in any of the following conditions.

1. Conditions and environments outside of the given specifications, or use outdoors or in a place exposed to direct sunlight.
2. Installation on equipment in conjunction with atomic energy, railways, air navigation, space, shipping, vehicles, military, medical treatment, combustion and recreation, or equipment in contact with food and beverages, emergency stop circuits, clutch and brake circuits in press applications, safety equipment or other applications unsuitable for the standard specifications described in the product catalogue.
3. An application which could have negative effects on people, property, or animals requiring special safety analysis.
4. Use in an interlock circuit, which requires the provision of double interlock for possible failure by using a mechanical protective function, and periodical checks to confirm proper operation.

Caution

1. The product is provided for use in manufacturing industries.

The product herein described is basically provided for peaceful use in manufacturing industries.

If considering using the product in other industries, consult SMC beforehand and exchange specifications or a contract if necessary.

If anything is unclear, contact your nearest sales branch.

Limited warranty and Disclaimer/ Compliance Requirements

The product used is subject to the following “Limited warranty and Disclaimer” and “Compliance Requirements”.

Read and accept them before using the product.

Limited warranty and Disclaimer

1. The warranty period of the product is 1 year in service or 1.5 years after the product is delivered.*2)

Also, the product may have specified durability, running distance or replacement parts. Please consult your nearest sales branch.

2. For any failure or damage reported within the warranty period which is clearly our responsibility, a replacement product or necessary parts will be provided.

This limited warranty applies only to our product independently, and not to any other damage incurred due to the failure of the product.

3. Prior to using SMC products, please read and understand the warranty terms and disclaimers noted in the specified catalogue for the particular products.

*2) Vacuum pads are excluded from this 1 year warranty.

A vacuum pad is a consumable part, so it is warranted for a year after it is delivered. Also, even within the warranty period, the wear of a product due to the use of the vacuum pad or failure due to the deterioration of rubber material are not covered by the limited warranty.

Compliance Requirements

1. The use of SMC products with production equipment for the manufacture of weapons of mass destruction (WMD) or any other weapon is strictly prohibited.

2. The exports of SMC products or technology from one country to another are governed by the relevant security laws and regulations of the countries involved in the transaction. Prior to the shipment of a SMC product to another country, assure that all local rules governing that export are known and followed.

Safety Instructions

Be sure to read “Handling Precautions for SMC Products” (M-E03-3) before using.

SMC Corporation (Europe)

Austria	+43 (0)226228200	www.smc.at	office@smc.at
Belgium	+32 (0)33551464	www.smc-pneumatics.be	info@smc-pneumatics.be
Bulgaria	+359 (0)2807670	www.smc.bg	office@smc.bg
Croatia	+385 (0)13707288	www.smc.hr	office@smc.hr
Czech Republic	+420 541424611	www.smc.cz	office@smc.cz
Denmark	+45 70252900	www.smc.dk.com	smc@smcdk.com
Estonia	+372 6510370	www.smc-pneumatics.ee	smc@smc-pneumatics.ee
Finland	+358 207513513	www.smc.fi	smc.fi@smc.fi
France	+33 (0)164761000	www.smc-france.fr	promotion@smc-france.fr
Germany	+49 (0)61034020	www.smc-pneumatik.de	info@smc-pneumatik.de
Greece	+30 210 2717265	www.smchellas.gr	sales@smchellas.gr
Hungary	+36 23511390	www.smc.hu	office@smc.hu
Ireland	+353 (0)14039000	www.smc-pneumatics.ie	sales@smc-pneumatics.ie
Italy	+39 0292711	www.smcitalia.it	mailbox@smcitalia.it
Latvia	+371 67817700	www.smc.lv	info@smc.lv

Lithuania	+370 5 2308118	www.smc.lt	info@smc.lt
Netherlands	+31 (0)205318888	www.smc-pneumatics.nl	info@smc-pneumatics.nl
Norway	+47 67129020	www.smc-norge.no	post@smc-norge.no
Poland	+48 (0)222119616	www.smc.pl	office@smc.pl
Portugal	+351 226166570	www.smc.eu	postpt@smc.smces.es
Romania	+40 213205111	www.smcromania.ro	smcromania@smcromania.ro
Russia	+7 8127185445	www.smc-pneumatik.ru	info@smc-pneumatik.ru
Slovakia	+421 (0)413213212	www.smc.sk	office@smc.sk
Slovenia	+386 (0)73885412	www.smc.si	office@smc.si
Spain	+34 902184100	www.smc.eu	post@smc.smces.es
Sweden	+46 (0)86031200	www.smc.nu	post@smc.nu
Switzerland	+41 (0)523963131	www.smc.ch	info@smc.ch
Turkey	+90 212 489 0 440	www.smc-pneumatik.com.tr	info@smc-pneumatik.com.tr
UK	+44 (0)845 121 5122	www.smc-pneumatics.co.uk	sales@smc-pneumatics.co.uk