

# 5/2, 5/3, 2x3/2 пневмораспределители с электропневматическим управлением VQC1000/2000/4000

- Исполнения с притертым стальным золотником и с эластичными уплотнениями золотника
- Простота сборки пневмораспределителей в блок благодаря многоконтактным разъемам на каждом модуле
- Возможность прямого использования в промышленных управляющих сетях (Profibus, DeviceNet, CANOpen, Asi)
- Высокая пропускная способность при компактной конструкции
- Ресурс более 200 млн. циклов (для исполнения со стальным золотником)
- Высокая скорость срабатывания (время реакции менее 10 мс)
- Наличие сдвоенных пневмораспределителей 2x3/2 (для VQC1000/2000 с эластичными уплотнениями золотника)

## Технические характеристики

Исполнение		С притертым стальным золотником	С эластичными уплотнениями золотника	
Среда		Очищенный сжатый воздух с содержанием масла или без него, инертный газ		
VQC 1000/2000	Макс. рабочее давление (МПа)	0.7		
	Мин. рабочее давление (МПа)	5/2 моностабильный	0.1	0.2
		5/2 бистабильный	0.1	
5/3	0.1	0.2		
VQC 4000	Макс. рабочее давление (МПа)	1.0		
	Мин. рабочее давление (МПа)	5/2 моностабильный	0.15	0.2
		5/2 бистабильный	0.15	
5/3	0.15	0.2		
Испытательное давление (МПа)		1.5		
Температура рабочей и окружающей среды (°C)		-10 ~ 50		
Вспомогательное ручное управление		С блокировкой		
Устойчивость к удару/вибрации (м/с <sup>2</sup> )		150/30 <sup>1)</sup>		
Степень защиты		IP67 <sup>2)</sup>		
Напряжение питания (В, DC)		24		
Допуск по напряжению		±10% от номинального значения		
Класс изоляции		В		
Искрогашение		Стандартное исполнение		
Индикатор рабочего состояния		Стандартное исполнение		

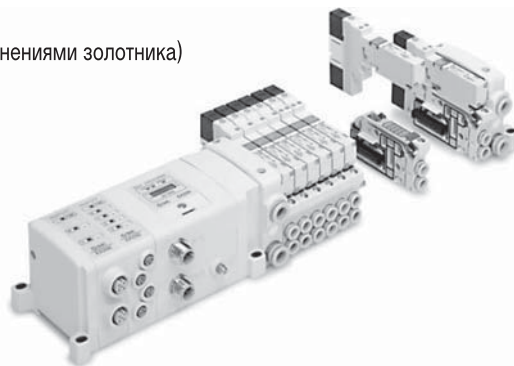

- 1) Условия испытаний: вибрация с частотой от 8.3 до 2000 Гц в осевом и перпендикулярном направлениях, во включенных и выключенном состояниях; однократный удар в осевом и перпендикулярном направлениях, во включенном и выключенном состояниях.
- 2) Для исполнений с терминальной коробкой и интерфейсными модулями EX500/250/260.

## Варианты электрического подключения

<p><b>Интерфейсный модуль EX260</b></p> <p><b>IP67</b></p>	<p><b>Интерфейсный модуль EX250</b></p> <p><b>IP67</b></p>	<p><b>Стандартный 25-контактный разъем</b></p> <p><b>IP40</b></p>
<p><b>20, 26-контактный плоский разъем (по запросу)</b></p> <p><b>IP67</b></p>	<p><b>26-контактный круглый разъем (по запросу)</b></p> <p><b>IP67</b></p>	<p><b>Терминальная коробка</b></p>

# 5/2, 5/3, 2x3/2 пневмораспределители с электропневматическим управлением VQC1000/2000/4000

## Номера для заказа

		Для VQC1000					Для VQC2000				
Принцип действия	Условное обозначение	Конструктивное исполнение	Номер для заказа	Расход (норм. л/мин)	Время реакции (мс) *	Вес (г)	Номер для заказа	Расход (норм. л/мин)	Время реакции (мс) *	Вес (г)	
5/2	Моно-стабильный		Стальной золотник	VQC1100N-5B	160	12	64	VQC2100N-5B	451	22	90
			Золотник с эластичными уплотнениями	VQC1101N-5B	210	15		VQC2101N-5B	540	24	
5/2	Би-стабильный		Стальной золотник	VQC1200N-5B	160	10	78	VQC2200N-5B	451	15	110
			Золотник с эластичными уплотнениями	VQC1201N-5B	210	15		VQC2201N-5B	540	20	
5/3	Закрытый центр		Стальной золотник	VQC1300N-5B	160	20		VQC2300N-5B	451	29	
			Золотник с эластичными уплотнениями	VQC1301N-5B		25		VQC2301N-5B	481	34	
	Открытый центр		Стальной золотник	VQC1400N-5B		20		VQC2400N-5B	451	29	
			Золотник с эластичными уплотнениями	VQC1401N-5B		25		VQC2401N-5B	481	34	
	Центр под давлением		Стальной золотник	VQC1500N-5B	210	20		VQC2500N-5B	560	29	
			Золотник с эластичными уплотнениями	VQC1501N-5B		25		VQC2501N-5B	785	34	
2x3/2	Н.З./Н.З.		Золотник с эластичными уплотнениями	VQC1A01N-5B	160	25		VQC2A01N-5B	451	34	
	Н.О./Н.О.		VQC1B01N-5B	VQC2B01N-5B							
	Н.З./Н.О.		VQC1C01N-5B	VQC2C01N-5B							

## Для VQC4000

\* При давлении 0.5 МПа

Принцип действия	Условное обозначение	Конструктивное исполнение	Номер для заказа	Расход (норм. л/мин)	Время реакции (мс) *	Вес (г)
5/2	Моностабильный	Стальной золотник	VQC4100-5B	1472	20	230
		Золотник с эластичными уплотнениями	VQC4101-5B	2061	25	
	Бистабильный	Стальной золотник	VQC4200-5B	1472	12	260
Золотник с эластичными уплотнениями	VQC4201-5B	2061	15			
5/3	Закрытый центр	Стальной золотник	VQC4300-5B	1472	45	280
		Золотник с эластичными уплотнениями	VQC4301-5B	1865	50	
	Открытый центр	Стальной золотник	VQC4400-5B	1472	45	
		Золотник с эластичными уплотнениями	VQC4401-5B	1865	50	
	Центр под давлением	Стальной золотник	VQC4500-5B	1865	45	
		Золотник с эластичными уплотнениями	VQC4501-5B		50	

## Принадлежности / Номера для заказа

### Крышка

Серия	Номер для заказа
VQC1000	VVQ1000-10A-1
VQC2000	VVQ2000-10A-1
VQC4000	VVQ4000-10A-1

Используется как заглушка, устанавливаемая на монтажную плиту вместо отсутствующего пневмораспределителя.

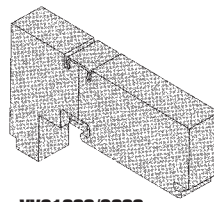

VVQ1000/2000

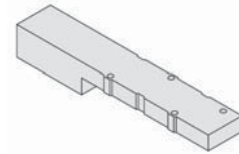

VVQ4000

### Индивидуальный подвод P

Серия	Присоединение	Номер для заказа
VQC1000	C6	VVQ1000-P-1-C6
VQC2000	C8	VVQ2000-P-1-C8
VQC4000	Rc 1/4	VVQ4000-P-1-02
	Rc 3/8	VVQ4000-P-1-03

Используется в комбинации с разделительной заглушкой, когда требуется подавать различные давления на пневмораспределители, собранные в блок.

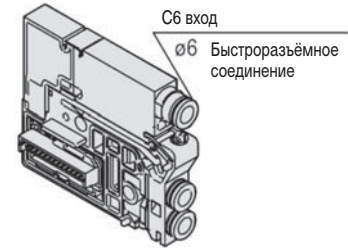
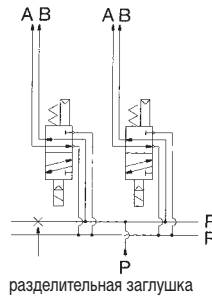

C6 вход

∅6 Быстроразъёмное соединение

### Индивидуальный выпуск

Серия	Присоединение	Номер для заказа
VQC1000	C6	VVQ1000-R-1-C6
VQC2000	C8	VVQ2000-R-1-C8
VQC4000	Rc 1/4	VVQ4000-R-1-02
	Rc 3/8	VVQ4000-R-1-03

Если деаэрация какого-либо пневмораспределителя неблагоприятно влияет на работу других пневмораспределителей, следует использовать модуль индивидуального выпуска.

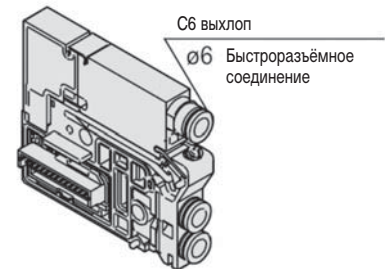
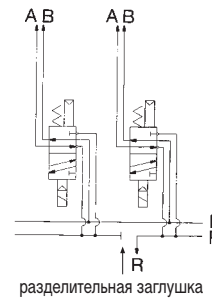

C6 выхлоп

∅6 Быстроразъёмное соединение

### Разделительная заглушка для изоляции канала P

Серия	Номер для заказа
VQC1000	VVQ1000-16A
VQC2000	VVQ2000-16A
VQC4000	VVQ4000-16A

Используется для разделения каналов подачи воздуха, чтобы обеспечить возможность работы одного блока пневмораспределителей с двумя различными давлениями.

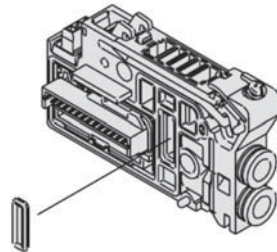

### Фитинг для соединения двух модулей

Серия	Номер для заказа
VQC1000	VVQ1000-52A-C8
VQC2000	VVQ2000-52A-C10

Используется для параллельного соединения двух соседних пневмораспределителей с целью увеличения расхода. Применяются быстроразъёмные соединения.

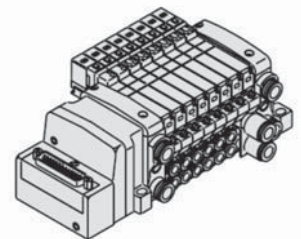

### Комплект для монтажа на DIN-рейке

Серия	Номер для заказа
VQC1000	VVQ1000-57A
VQC2000	VVQ2000-57A

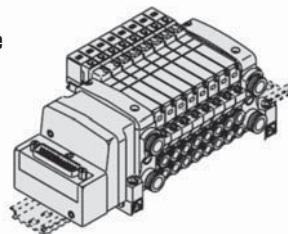

### Маркировочная пластина

Серия	Номер для заказа*
VQC1000	VVQ1000-N-□
VQC2000	VVQ2000-N-□

\* □ – количество секций.

Используется для маркировки пневмораспределителей в блоке.

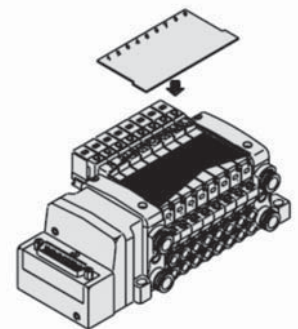

### Обратные клапаны

Серия	Номер для заказа
VQC1000	VVQ1000-18A
VQC2000	VVQ2000-18A

Предотвращают перемещение штока пневмоцилиндра, вызванное деаэрационным давлением других пневмораспределителей. Устанавливаются в канале выхлопа (R). Используются в 5/3 пневмораспределителях с открытым центром.

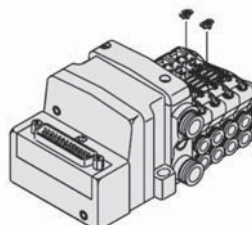

# 5/2, 5/3, 2x3/2 пневмораспределители с электропневматическим управлением VQC1000/2000/4000

## Принадлежности / Номера для заказа

### Соединение угловое

Серия	Присоединит. размер	Номер для заказа
VQC1000	∅3.2	VVQ1000-F-LC3
	∅4	VVQ1000-F-LC4
	∅6	VVQ1000-F-LC6
	M5	VVQ1000-F-LM5
VQC2000	∅4	VVQ2000-F-LC4
	∅6	VVQ2000-F-LC6
	∅8	VVQ2000-F-LC8

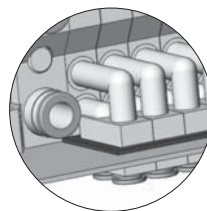
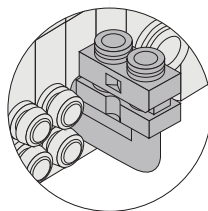

Обеспечивает присоединение трубок под углом 90° к оси выходных портов пневмораспределителя.

### Пневмоглушитель

Серия	Номер для заказа
VQC1000	AN200-KM8
VQC2000	AN200-KM10
VQC4000	ANA1-06

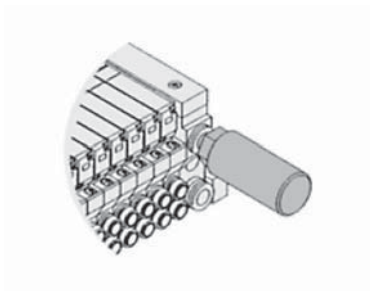

### Заглушка

Серия	Присоединит. размер (мм)	Номер для заказа
VQC1000	∅3.2	KQ2P-23
VQC2000	∅4	KQ2P-04
	∅6	KQ2P-06
	∅8	KQ2P-08

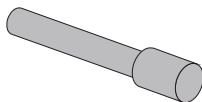

Используется для закрытия неиспользуемых портов А и В.

### Интерфейсный регулятор

Применяется для пневмораспределителей серии VQC4000.

Регулирует подачу воздуха на пневмораспределитель, обеспечивая заданный уровень давления:

- на входе (тип P),
- на выходе А (тип А),
- на выходе В (тип В).

Тип	P	A	B
Схема			
Номер для заказа	ARBQ4000-00-P-1	ARBQ4000-00-A-1	ARBQ4000-00-B-1







## Блок пневмораспределителей (IP40)

### VQC1000/2000/4000

Тип электрического подключения – 25-контактный разъем

- Центральное подключение блока пневмораспределителей посредством разъема по DIN.
- Штекерное соединение по стандарту MIL (25-контактный).
- Макс. 12 пневмораспределителей с двусторонним управлением.
- Мин. возможный радиус изгиба 55 мм.

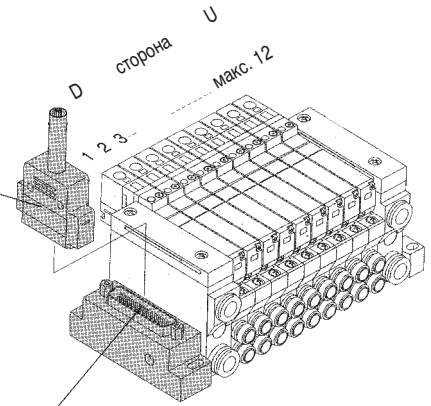

### Ответная часть разъема с кабелем

№ контакта	Цветовой код по DIN47100	
	Основной цвет жилы	Маркировка жилы
1	белый	-
2	коричневый	-
3	зеленый	-
4	желтый	-
5	серый	-
6	розовый	-
7	синий	-
8	красный	-
9	черный	-
10	фиолетовый	-
11	серый	розовая
12	красный	синяя
13	белый	зеленая
14	коричневый	зеленая
15	белый	желтая
16	желтый	коричневая
17	белый	серая
18	серый	коричневая
19	белый	розовая
20	розовый	коричневая
21	белый	синяя
22	коричневый	синяя
23	белый	красная
24	коричневый	красная
25	белый	черная

### Ответная часть разъема

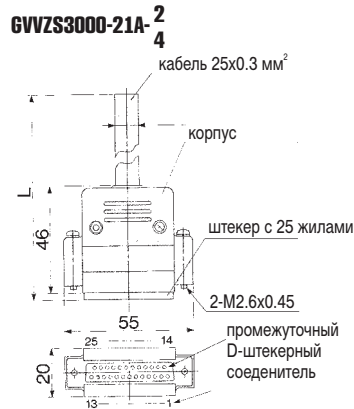

### Обозначение длины L

Номер для заказа	Длина L
GVVZS3000-21A-2	3м
GVVZS3000-21A-3	5м
GVVZS3000-21A-4	8м

### Электрические свойства

Позиция	Свойства
Сопротивление проводника	~57 (Ом/км 20° C)
Прочность на пробой по VDE 0472	1500 В свыше 5 мм
Сопротивление изоляции	20 МОм

### Разъем 25-контактный

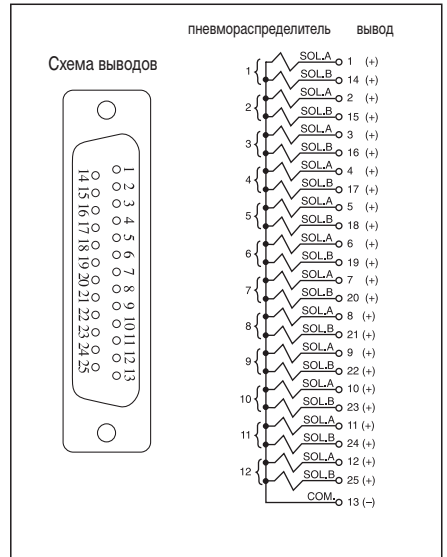

# 5/2, 5/3, 2x3/2 пневмораспределители с электропневматическим управлением VQC1000/2000/4000

## Размеры

### VV5QC11

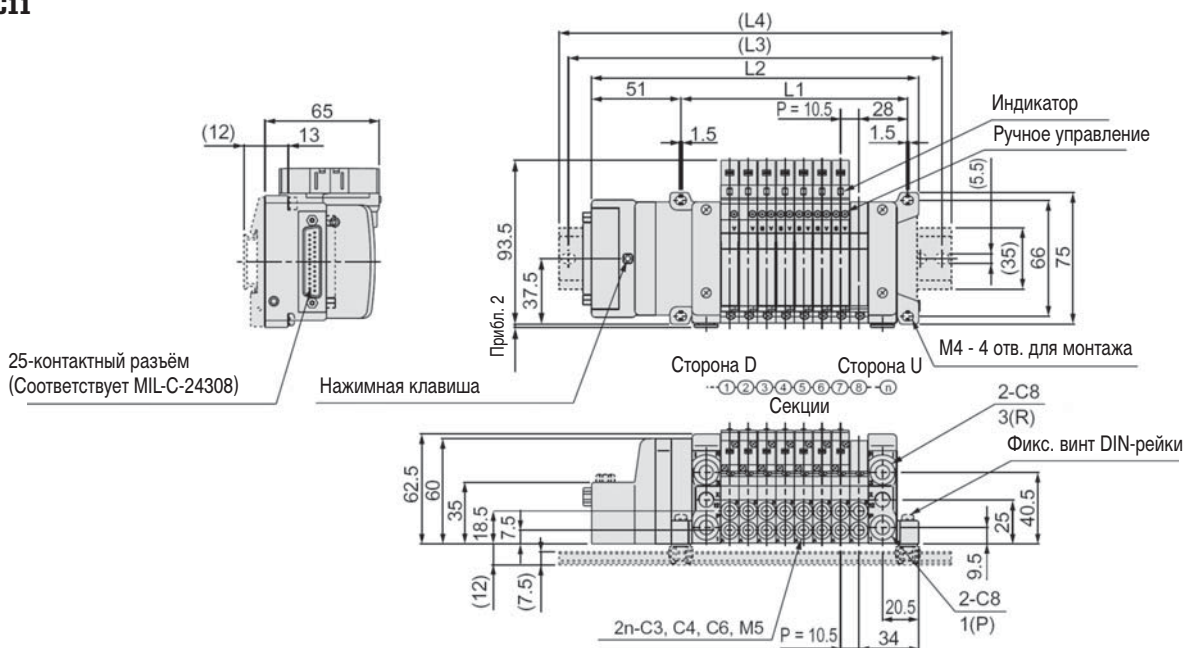

Расчетная формула:  $L1 = 10.5n + 45$ ,  
 $L2 = 10.5n + 102$     n: количество секций (максимум 24)

L \ n	1	2	3	4	5	6	7	8	9	10	11	12	13	14	15	16	17	18	19	20	21	22	23	24
L1	55.5	66	76.5	87	97.5	108	118.5	129	139.5	150	160.5	171	181.5	192	202.5	213	223.5	234	244.5	255	265.5	276	286.5	297
L2	112.5	123	133.5	144	154.5	165	175.5	186	196.5	207	217.5	228	238.5	249	259.5	270	280.5	291	301.5	312	322.5	333	343.5	354
L3	137.5	150	162.5	175	175	187.5	200	212.5	225	237.5	237.5	250	262.5	275	287.5	300	300	312.5	325	337.5	350	362.5	375	375
L4	148	160.5	173	185.5	185.5	198	210.5	223	235.5	248	248	260.5	273	285.5	298	310.5	310.5	323	335.5	348	360.5	373	385.5	385.5

### VV5QC21

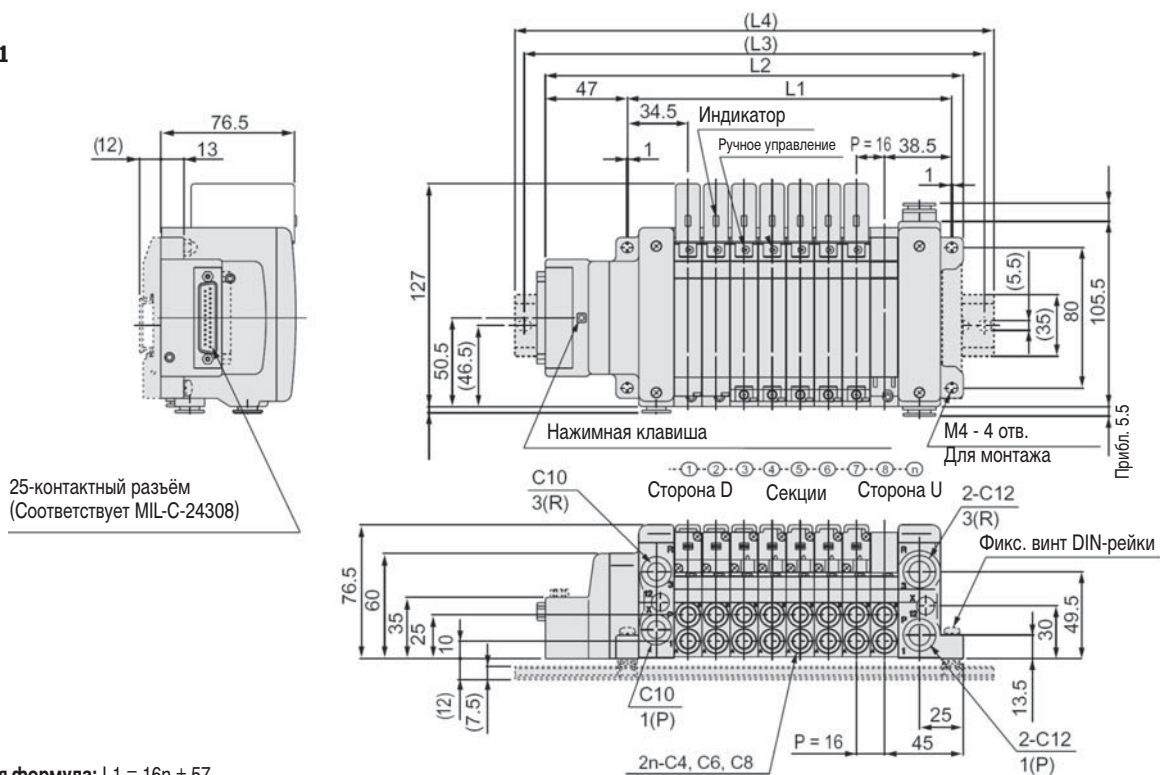

Расчетная формула:  $L1 = 16n + 57$ ,  
 $L2 = 16n + 110.5$     n: количество секций (максимум 24)

L \ n	1	2	3	4	5	6	7	8	9	10	11	12	13	14	15	16	17	18	19	20	21	22	23	24
L1	73	89	105	121	137	153	169	185	201	217	233	249	265	281	297	313	329	345	361	377	393	409	425	441
L2	126.5	142.5	158.5	174.5	190.5	206.5	222.5	238.5	254.5	270.5	286.5	302.5	318.5	334.5	350.5	366.5	382.5	398.5	414.5	430.5	446.5	462.5	478.5	494.5
L3	150	162.5	187.5	200	212.5	237.5	250	262.5	275	300	312.5	325	350	362.5	375	387.5	412.5	425	437.5	450	475	487.5	500	525
L4	160.5	173	198	210.5	223	248	260.5	273	285.5	310.5	323	335.5	360.5	373	385.5	398	423	435.5	448	460.5	485.5	498	510.5	535.5



### Блок пневмораспределителей (IP67)

VQC1000/2000/4000

Тип электрического подключения – терминальная коробка

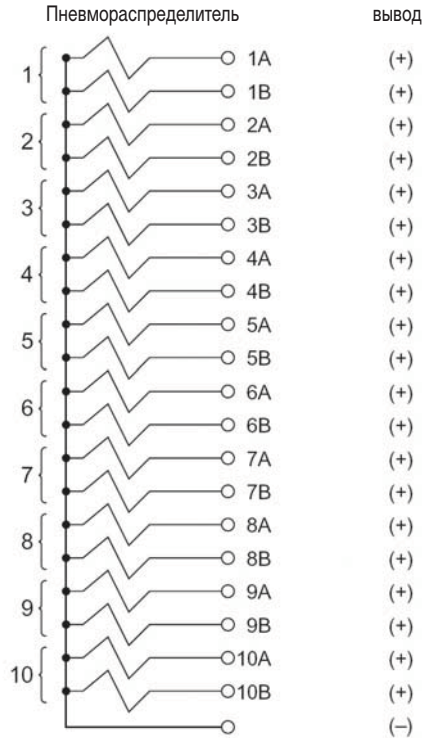
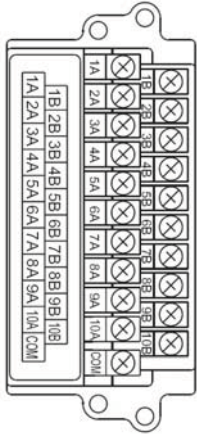

### Размеры

VV5QC11

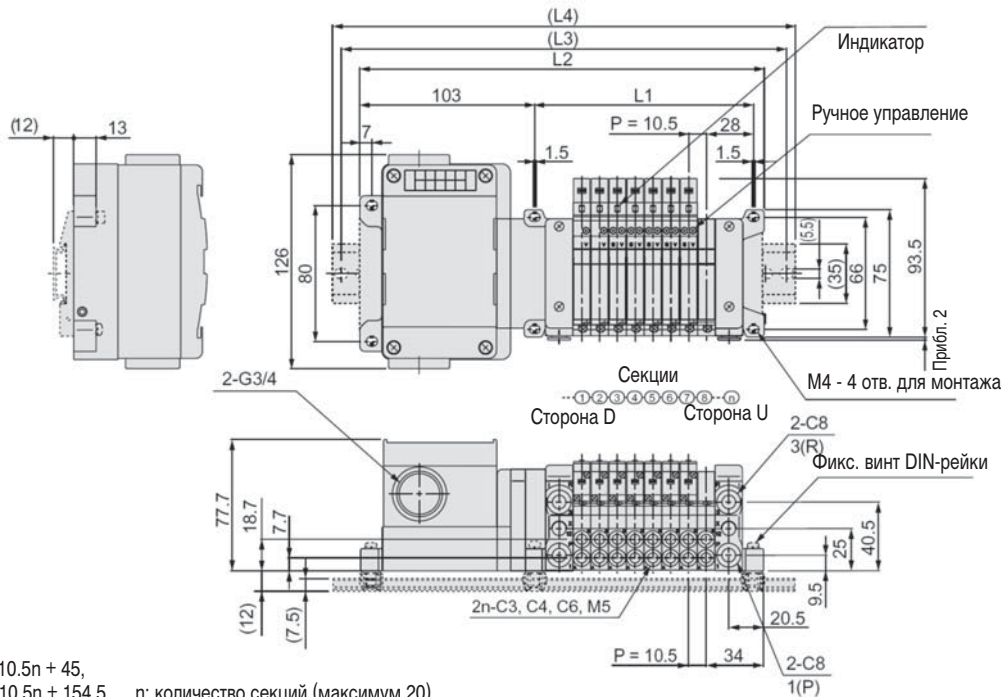

Расчетная формула:  $L1 = 10.5n + 45$ ,  
 $L2 = 10.5n + 154.5$  n: количество секций (максимум 20)

L \ n	1	2	3	4	5	6	7	8	9	10	11	12	13	14	15	16	17	18	19	20
L1	55.5	66	76.5	87	97.5	108	118.5	129	139.5	150	160.5	171	181.5	192	202.5	213	223.5	234	244.5	255
L2	165	175.5	186	196.5	207	217.5	228	238.5	249	259.5	270	280.5	291	301.5	312	322.5	333	343.5	354	364.5
L3	187.5	200	212.5	212.5	225	237.5	250	262.5	275	275	287.5	300	312.5	325	337.5	337.5	350	362.5	375	387.5
L4	198	210.5	223	223	235.5	248	260.5	273	285.5	285.5	298	310.5	323	335.5	348	348	360.5	373	385.5	398

Компания SMC сохраняет за собой право на внесение технических и размерных изменений



# 5/2, 5/3, 2x3/2 пневмораспределители с электропневматическим управлением VQC1000/2000/4000

## Размеры

### VV5QC21

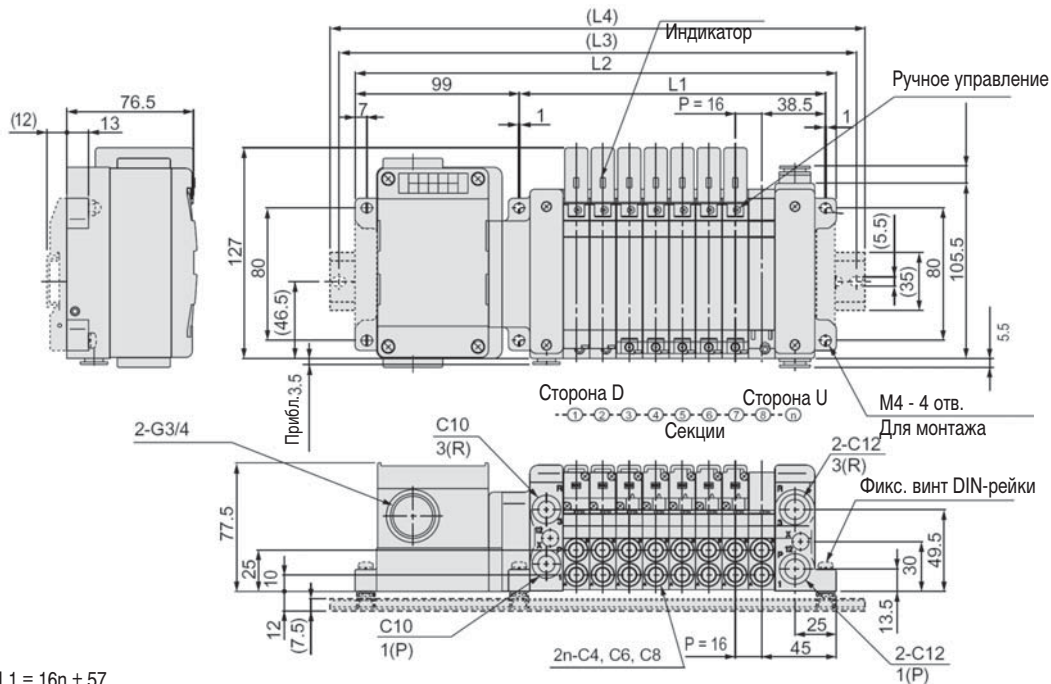

Расчетная формула:  $L1 = 16n + 57$ ,  
 $L2 = 16n + 163$  n: количество секций (максимум 20)

L \ n	1	2	3	4	5	6	7	8	9	10	11	12	13	14	15	16	17	18	19	20
L1	73	89	105	121	137	153	169	185	201	217	233	249	265	281	297	313	329	345	361	377
L2	179	195	211	227	243	259	275	291	307	323	339	355	371	387	403	419	435	451	467	483
L3	200	212.5	237.5	237.5	262.5	262.5	287.5	312.5	325	371	362.5	375	408.5	412.5	425	437.5	462.5	496	487.5	500
L4	210.5	223	248	248	273	273	298	323	335.5	360.5	373	385.5	398	423	435.5	448	473	485.5	498	510.5

### VV5QC41

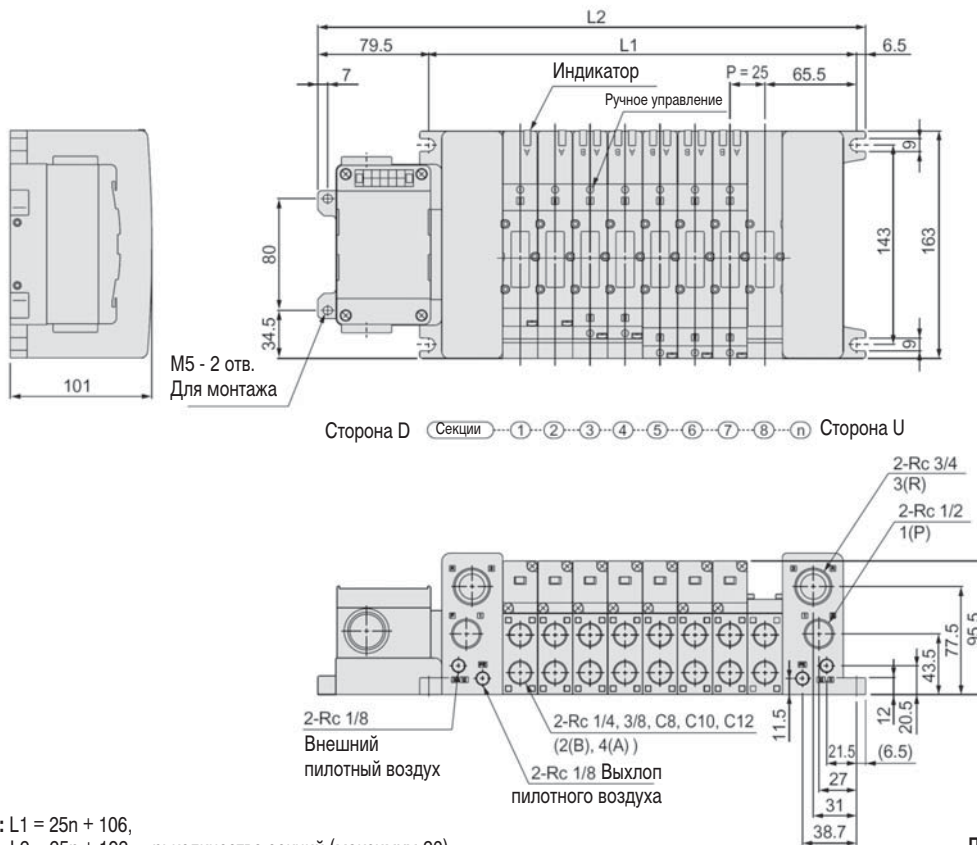

Расчетная формула:  $L1 = 25n + 106$ ,  
 $L2 = 25n + 192$  n: количество секций (максимум 20)

L \ n	1	2	3	4	5	6	7	8	9	10	11	12	13	14	15	16	17	18	19	20
L1	131	156	181	206	231	256	281	306	331	356	381	406	431	456	481	506	531	556	581	606
L2	217	242	267	292	317	342	367	392	417	442	467	492	517	542	567	592	617	642	667	692

Примечание:  
 для обеспечения степени защиты IP67 следует применять кабельный ввод FGA26S-14G (по запросу).

# 5/2, 5/3, 2x3/2 пневмораспределители с электропневматическим управлением VQC1000/2000/4000

## Блок пневмораспределителей

### Спецификация

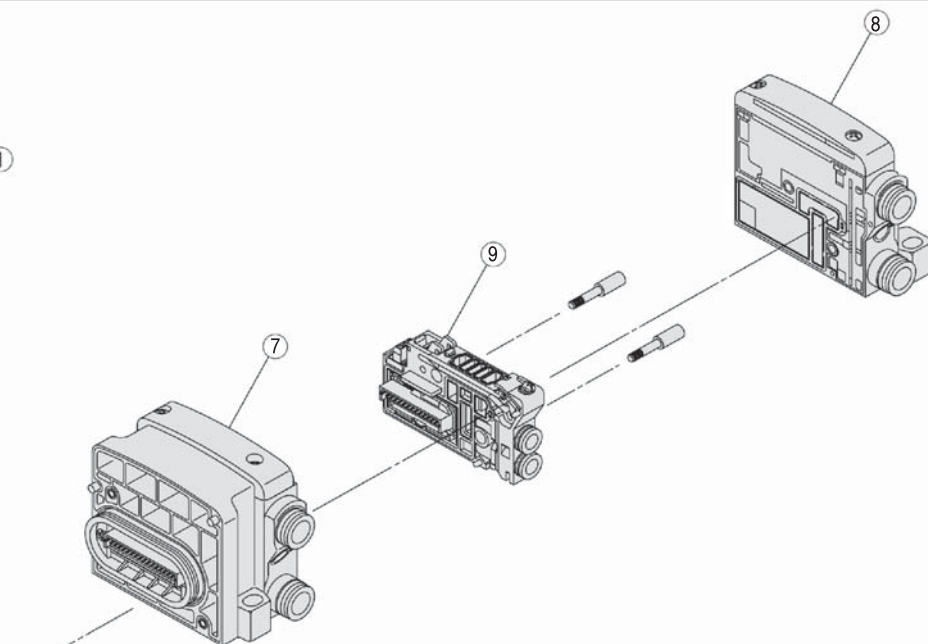
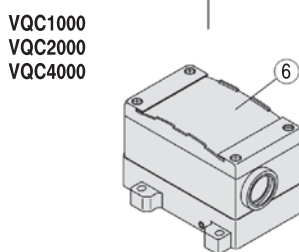
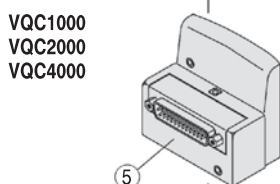
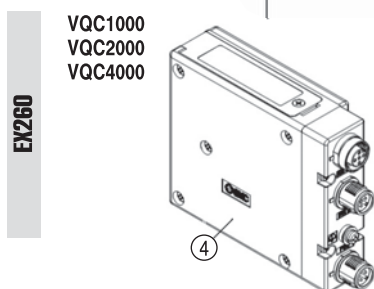
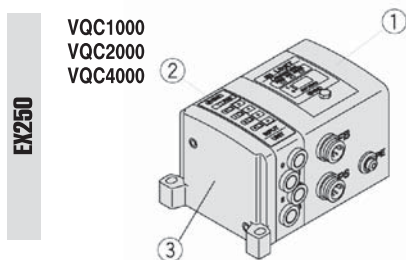

№	Название	Номер для заказа	Примечание		
1	Интерфейсный модуль EX250	EX250-SDN1	DeviceNet (-COM)		
		EX250-SPR1	PROFIBUS DP (-COM)		
		EX250-SCA1A	CANOpen (-COM)		
		EX250-SAS3	AS-I (-COM)	8 входов/8 выходов	Система с двумя подводами питания
		EX250-SAS5	4 входа/4 выхода		
		EX250-SAS7	8 входов/8 выходов	Система с одним подводом питания	
		EX250-SAS9	4 входа/4 выхода		
		EX250-SCN1	ControlNet (-COM)		
		EX250-SEN1	EtherNet/IP (-COM)		
		2	Модуль входов	EX250-IE1	M12, 2 входа
EX250-IE2	M12, 4 входа				
EX250-IE3	M8, 4 входа				
3	Концевая плата	EX250-EA1	Стандартная		
		EX250-EA2	Монтаж на DIN-рейке		
4	Компактный интерфейс модуль EX260	EX260-SDN1	DeviceNet (-COM)	32 выхода (PNP)	M12
		EX260-SDN2		32 выхода (NPN)	
		EX260-SDN3		16 выходов (PNP)	
		EX260-SDN4		16 выходов (NPN)	
		EX260-SPR1	PROFIBUS DP	32 выхода (PNP)	25-контактный разъем (D-sub)
		EX260-SPR2		32 выхода (NPN)	
		EX260-SPR3		16 выходов (PNP)	
		EX260-SPR4		16 выходов (NPN)	
		EX260-SPR5		32 выхода (PNP)	
		EX260-SPR6		32 выхода (NPN)	
		EX260-SPR7		16 выходов (PNP)	
		EX260-SPR8		16 выходов (NPN)	
		EX260-SEC1	EtherCAT	32 выхода (PNP)	M12
		EX260-SEC2		32 выхода (NPN)	
		EX260-SEC3		16 выходов (PNP)	
		EX260-SEC4		16 выходов (NPN)	
5	25-контактный разъем (D-sub)	VVQC1000-F25-1	IP40		
6	Терминальная коробка	VVQC1000-T0-1	IP67 (с кабельным вводом FGA26S-14G)		

Примечание: разъемы для подключения интерфейсных модулей поставляются по запросу

7	Концевая плата левая
---	----------------------

#### VQC1000/2000

Серия	Номер для заказа	Присоединение *
VQC1000	VVQC1000-3A-1-C8	C8
VQC2000	VVQC2000-3A-1-C10	C10

\* "C" быстроразъемное соединение, например: "C8" – ø8 мм

#### VQC4000

Тип электр. подвода	Номер для заказа
Интерфейсный модуль, 25-контактный разъем, терминальная коробка	VVQC4000-3A-2F

## Блок пневмораспределителей

8. Концевая плита правая

### VQC1000/2000/4000

Серия	Номер для заказа	Присоединение *	Расположение канала подвода/отвода воздуха
VQC1000	VVQC1000-2A-1-C8	C8	Спереди
VQC2000	VVQC2000-2A-1-C10	C10	Спереди
	VVQC2000-2A-2-C10		Спереди и сзади
	VVQC2000-2A-2-C12	C12	
VQC4000	VVQC4000-2A-1F	P: G1/2, R: G3/4	Спереди

\* "С" быстроразъемное соединение, например: "С8" –  $\varnothing$ 8 мм

9. Индивидуальная плита пневмораспределителя

Серия	Номер для заказа	Тип	Присоединение *
VQC1000	VVQC1000-1A-D-C3	Для бистабильного пневмораспределителя	C3
	VVQC1000-1A-D-C4		C4
	VVQC1000-1A-D-C6		C6
	VVQC1000-1A-D-M5		M5
	VVQC1000-1A-S-C3	Для 5/2 моностабильного пневмораспределителя	C3
	VVQC1000-1A-S-C4		C4
	VVQC1000-1A-S-C6		C6
	VVQC1000-1A-S-M5		M5
VQC2000	VVQC2000-1A-D-C4	Для бистабильного пневмораспределителя	C4
	VVQC2000-1A-D-C6		C6
	VVQC2000-1A-D-C8		C8
	VVQC2000-1A-S-C4	Для 5/2 моностабильного пневмораспределителя	C4
	VVQC2000-1A-S-C6		C6
	VVQC2000-1A-S-C8		C8
VQC4000	VVQC4000-1A-D-C8	Для бистабильного пневмораспределителя	C8
	VVQC4000-1A-D-C10		C10
	VVQC4000-1A-D-C12		C12
	VVQC4000-1A-D-02F		G 1/4"
	VVQC4000-1A-D-03F		G 3/8"
	VVQC4000-1A-D-BF		G 1/4" порт снизу
	VVQC4000-1A-S-C8		Для 5/2 моностабильного пневмораспределителя
	VVQC4000-1A-S-C10	C10	
	VVQC4000-1A-S-C12	C12	
	VVQC4000-1A-S-02F	G 1/4"	
	VVQC4000-1A-S-03F	G 3/8"	
	VVQC4000-1A-S-BF	G 1/4" порт снизу	

\* "С" быстроразъемное соединение, например: "С8" –  $\varnothing$ 8 мм



# 5 Port Solenoid Valve

Connector Type Manifold  
Metal Seal / Rubber Seal

IP67 enclosure compatible



Power saving

Standard: **0.4 w**

(Reduced by **60%** compared to existing model)

High-pressure (1 MPa, Metal seal): **0.95 w**

RoHS  
compliant



Series **VQC1000/2000**



CAT.EUS11-101Aa-UK

# Connector Type Manifold

## Series VQC1000/2000

### Power saving

Standard: **0.4 W** (Reduced by **60%** compared to existing model)  
High-pressure (1 MPa, Metal seal): **0.95 W**

### IP67 enclosure compatible Dust-tight, Immersion-proof

(Based on IEC60529) (S/T/L/M kit)

### Accommodates gateway-type serial wiring.

- Gateway unit types include DeviceNet™, PROFIBUS DP and EtherNet/IP™.
- Because just one gateway unit controls up to 4 branch lines, it offers much more freedom in choosing valve mounting locations in comparison with other serial units.
- Manifolds and input blocks can be mounted near the actuator, allowing for use of short air piping or electric wiring.
- The package wiring with connector cable reduces the potential for incorrect wiring and improves wiring efficiency.
- A single cable from the gateway provides both signal and power to each branch, thus eliminating the need for separate power connections for each manifold valve and input block.
- The input block also employs a multi-pin connector so that the number of stations can be changed easily, as with the manifold.

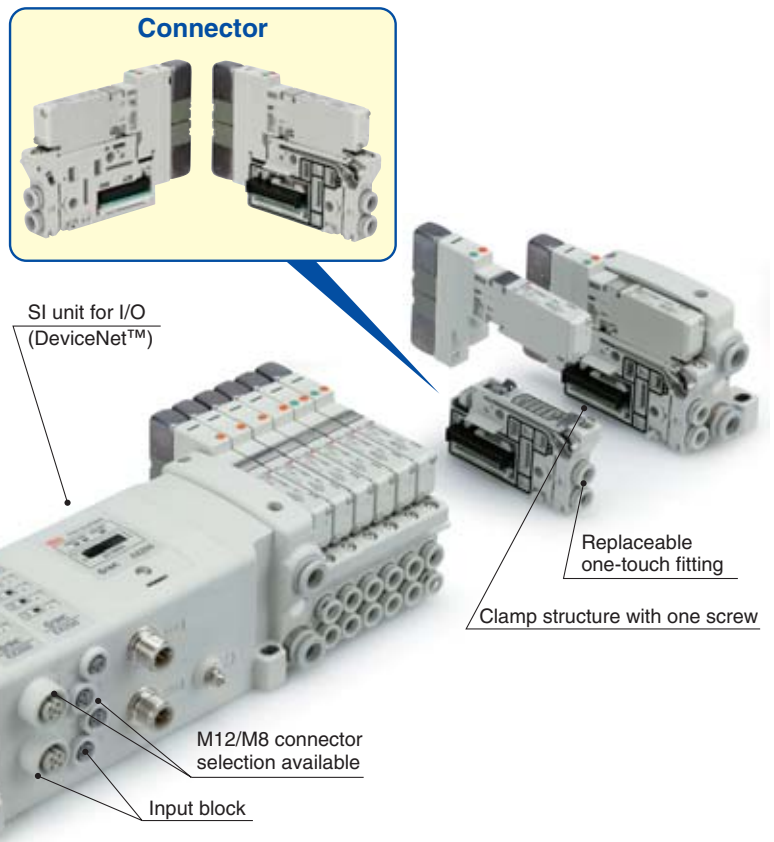

### Applicable to EX600 (Input/Output) serial transmission system (Fieldbus system)

- Available for DeviceNet™, PROFIBUS DP, CC-Link, EtherNet/IP™ and PROFINET fieldbus protocols.
- **Max. 9 units** <sup>Note)</sup> can be connected in any order.  
The unit to connect input device such as an auto switch, pressure switch and flow switch, and the unit to connect output device such as a solenoid valve, relay and indicator light can be connected in any order.  
Note) Except SI unit
- **Analogue Input/Output Unit can be connected with analogue devices.**  
As well as a Digital (switch) Input/Output Unit, a unit applicable to analogue signal is provided, and can be connected with various devices for control.
- **Self-diagnosis function**  
It is possible to ascertain the maintenance period and identify the parts that require maintenance, by an input (sensor) open circuit detecting function and an input/output signal of ON/OFF counter function. Also, the monitoring of input/output signal and the setting of parameters can be performed with a Handheld Terminal.





## Compact and high flow

Series	Manifold pitch (mm)	Flow-rate characteristics <small>Note)</small>						Applicable cylinder bore size (mm)
		Metal seal			Rubber seal			
		C [dm <sup>3</sup> /(s·bar)]	b	Cv	C [dm <sup>3</sup> /(s·bar)]	b	Cv	
<b>VQC1000</b>	10.5	0.72	0.25	0.18	1.0	0.30	0.25	Up to ø50
<b>VQC2000</b>	16	2.6	0.15	0.60	3.2	0.30	0.80	Up to ø80

Note) Flow-rate characteristics: 2-position single, 4/2 → 5/3 (A/B → R1/R2)

## Connector entry direction can be changed with a single push. (F/P kit)

The connector entry direction can be changed from the top to the side by simply pressing the manual release button.

It is not necessary to use the manual release button when switching from the side to the top.

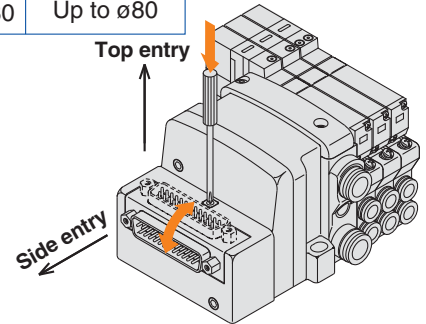

## A wide variety of prepackaged wiring configurations

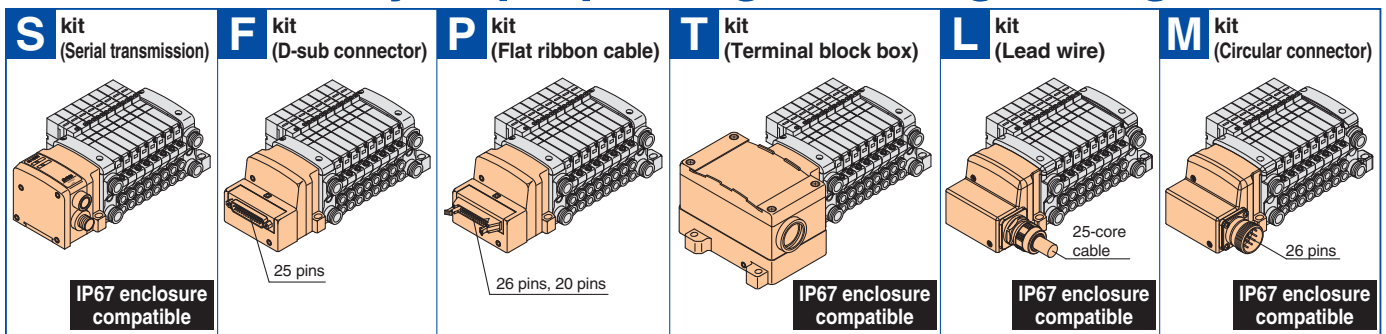

- Our six standard wiring packages bring a world of ease to wiring and maintenance work, while the protective enclosures of four of them conform to IP67 standards.
- The S kit is compatible with a combined I/O unit. (Not applicable to Gateway unit)

## Connector type manifold

- The use of multi-pin connectors to replace wiring inside manifold blocks provides flexibility when adding stations or changing manifold configuration.
- All kits use multi-pin connectors, so switching from the F kit (D-sub connector) to the S kit (serial transmission) can be done simply by changing the kit section.

(Refer to the connector wiring diagram.)

Printed circuit board patterns between connectors are shifted at every station. This allows for viable connections to take place without necessarily specifying whether the manifold station is double, single, or mixed wiring.

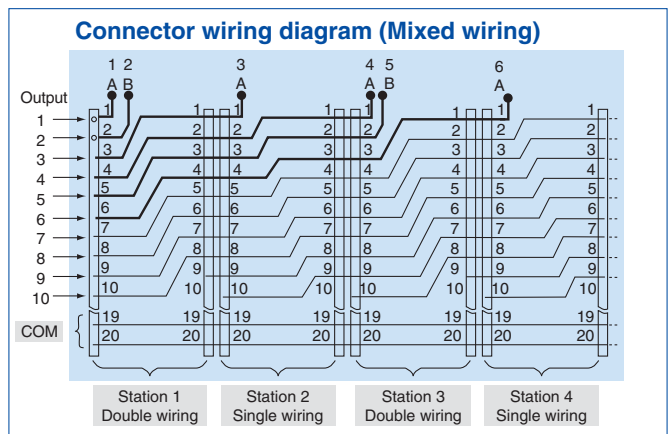

## Dual 3-port valves, 4 positions

VQC1000/2000 (Rubber seal only)

- Two 3-port valves built into one body
- The 3-port valves on the A and B sides can operate independently.
- When used as 3-port valves, only half the number of stations is required.
- Can also be used as a 4-position, 5-port type valve.

Exhaust centre : **VQC1A01**  
**VQC2A01**  
 Pressure centre : **VQC1B01**  
**VQC2B01**

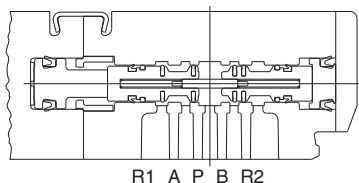

Model	A side	B side	JIS symbol
<b>VQC1A01</b> <b>VQC2A01</b>	N.C. valve	N.C. valve	
<b>VQC1B01</b> <b>VQC2B01</b>	N.O. valve	N.O. valve	
<b>VQC1C01</b> <b>VQC2C01</b>	N.C. valve	N.O. valve	

# Series VQC/Base Mounted: Variations

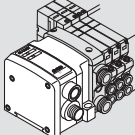
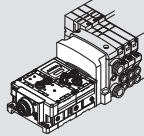
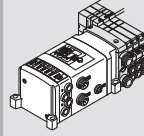
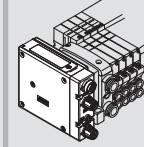
			Sonic conductance C [dm <sup>3</sup> /(s·bar)] (CYL → EXH) 4/2 → 5/3		Applicable cylinder bore size		S kit																	
							Serial transmission																	
			Single/Double 3-position (Closed center)				Gateway application Compatible network • DeviceNet™ • PROFIBUS DP • EtherNet/IP™ <b>Decentralized Serial Wiring</b> Gateway application requires a gateway unit and communication cable separately. Please contact SMC for details.																	
							I/O  Serial unit: EX500 IP67 compliant					I/O  Serial unit (Fieldbus system): EX600 IP67 compliant					I/O  Serial unit: EX250 IP67 compliant					Output  Serial unit: EX260 IP67 compliant		
Series VQC1000 P. 5	Metal seal	VQC1□00	0.72	0.72	Up to ø50	●	●	●	●	●														
	Rubber seal	VQC1□01	1.0	0.65																				
Series VQC2000 P. 11	Metal seal	VQC2□00	2.6	2.0	Up to ø80	●	●	●	●	●														
	Rubber seal	VQC2□01	3.2	2.2																				

# 5 Port Solenoid Valve *Series VQC1000/2000*

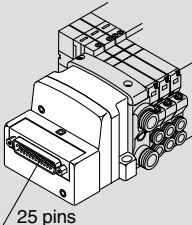
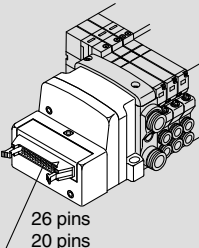
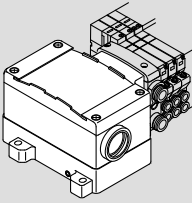
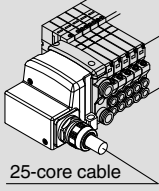
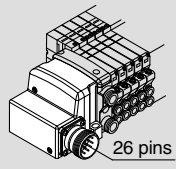
	<b>F kit</b>	<b>P kit</b>	<b>T kit</b>	<b>L kit</b>	<b>M kit</b>	Port size	
	<b>D-sub connector</b>	<b>Flat ribbon cable</b>	<b>Terminal block box</b>	<b>Electrical entry</b>	<b>Circular connector</b>		
	<b>D-sub connector</b> (Conforming to MIL D-sub connector)	<b>Flat ribbon cable</b> (Conforming to MIL flat ribbon cable connector)	<b>Terminal block box (Terminal block)</b> (Terminal block is compactly arranged on one side.)	<b>Lead wire</b> (IP67 enclosure with use of multiple wire cable with sheath and waterproof connector)	<b>Circular connector</b> (IP67 enclosure with use of waterproof circular connector)		
	 25 pins	 26 pins 20 pins	 <b>IP67 compliant</b>	 25-core cable <b>IP67 compliant</b>	 26 pins <b>IP67 compliant</b>	<b>SUP EXH port</b>	<b>Cylinder port</b>
						1, 3 (P, R)	2, 4 (A, B)
	●	●	●	●	●	<b>C8 (ø8)</b>	<b>C3 (ø3.2)</b> <b>C4 (ø4)</b> <b>C6 (ø6)</b> <b>M5 (M5 thread)</b>
						<b>N9 (ø5/16")</b>	<b>N1 (ø1/8")</b> <b>N3 (ø5/32")</b> <b>N7 (ø1/4")</b>
	●	●	●	●	●	<b>C10 (ø10)</b> <b>N11 (ø3/8")</b>	<b>C4 (ø4)</b> <b>C6 (ø6)</b> <b>C8 (ø8)</b>
						<b>In case of branch type</b> <b>C12 (ø12)</b> <b>N13 (ø1/2")</b>	<b>N3 (ø5/32")</b> <b>N7 (ø1/4")</b> <b>N9 (ø5/16")</b>

# Series VQC1000/2000

## Cylinder Speed Chart

This chart is provided as guidelines only.  
For performance under various conditions, use SMC's Model Selection Program before making a judgment.

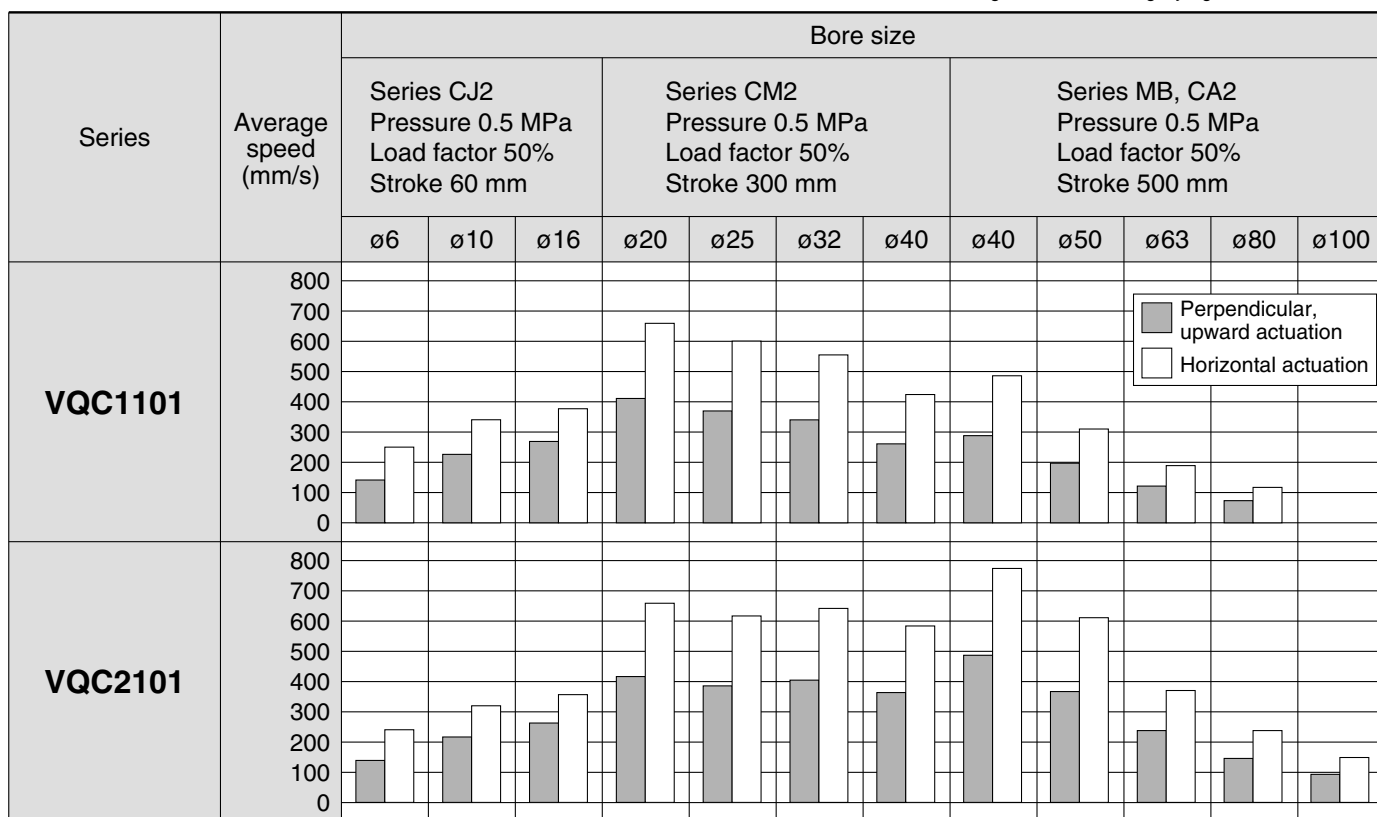

-  Note 1) It is when the cylinder is extending that is meter-out controlled by speed controller which is directly connected with cylinder, and its needle valve with being fully open.  
 Note 1) The average velocity of the cylinder is what the stroke is divided by the total stroke time.  
 Note 1) Load factor:  $((\text{Load mass} \times 9.8) / \text{Theoretical force}) \times 100\%$

### Conditions

Series	Conditions	Series CJ2	Series CM2	Series MB, CA2
VQC1101	Tube x Length	T0604 (O.D. ø6/I.D. ø4) x 1 m		
	Speed controller	AS3001F-06		
	Silencer	AN200-KM8		
VQC2101	Tube x Length	T0806 (O.D. ø8/I.D. ø6) x 1 m		
	Speed controller	AS3001F-08		
	Silencer	AN200-KM10		

# INDEX

Features .....	<b>Features 1</b>
Variations .....	<b>P. 1</b>
Cylinder Speed Chart .....	<b>P. 3</b>
<b>VQC1000</b> How to Order, Manifold Options .....	<b>P. 5</b>
<b>VQC2000</b> How to Order, Manifold Options .....	<b>P. 11</b>
<b>VQC1000/2000</b> Model, Standard/Manifold Specifications ...	<b>P. 17</b>
 <b>VQC1000/2000</b> <b>S</b> kit (Serial transmission) EX500 .....	 <b>P. 19</b>
 <b>VQC1000/2000</b> <b>S</b> kit (Serial transmission [Fieldbus system]) EX600 .....	 <b>P. 23</b>
 <b>VQC1000/2000</b> <b>S</b> kit (Serial transmission) EX250 .....	 <b>P. 27</b>
 <b>VQC1000/2000</b> <b>S</b> kit (Serial transmission) EX260 .....	 <b>P. 28</b>
 <b>VQC1000/2000</b> <b>S</b> kit (Serial transmission) EX126 .....	 <b>P. 31</b>
 <b>VQC1000/2000</b> <b>F</b> kit (D-sub connector) .....	 <b>P. 33</b>
 <b>VQC1000/2000</b> <b>P</b> kit (Flat ribbon cable) .....	 <b>P. 35</b>
 <b>VQC1000/2000</b> <b>T</b> kit (Terminal block box) .....	 <b>P. 37</b>
 <b>VQC1000/2000</b> <b>L</b> kit (Lead wire) .....	 <b>P. 39</b>
 <b>VQC1000/2000</b> <b>M</b> kit (Circular connector) .....	 <b>P. 41</b>
 <b>VQC1000/2000</b> Construction .....	 <b>P. 43</b>
<b>VQC1000/2000</b> Exploded View of Manifold .....	<b>P. 45</b>
<b>VQC1000/2000</b> Manifold Optional Parts .....	<b>P. 49</b>
<b>VQC1000/2000</b> Specific Product Precautions .....	<b>P. 56</b>

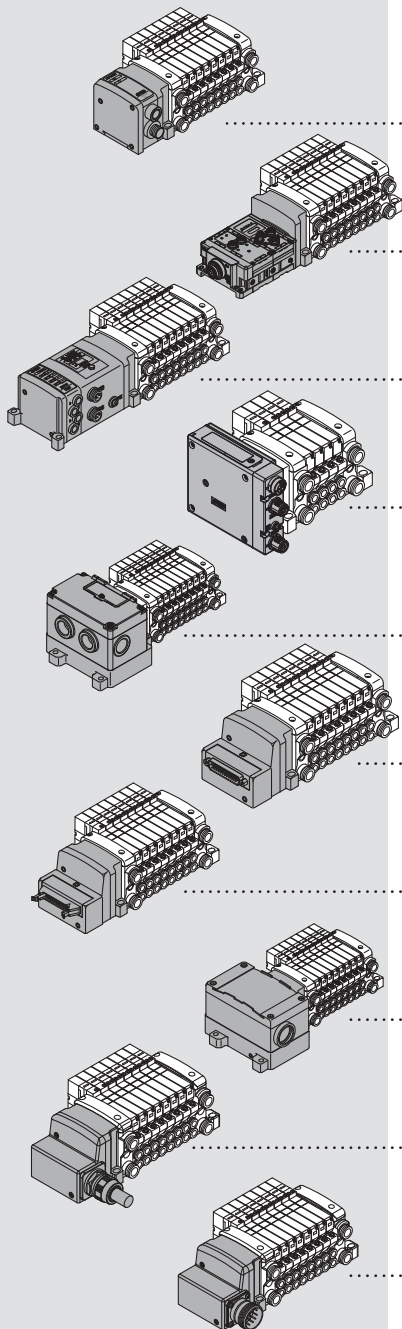



# Base Mounted Plug-in Unit Series VQC1000 C €

## How to Order Manifold

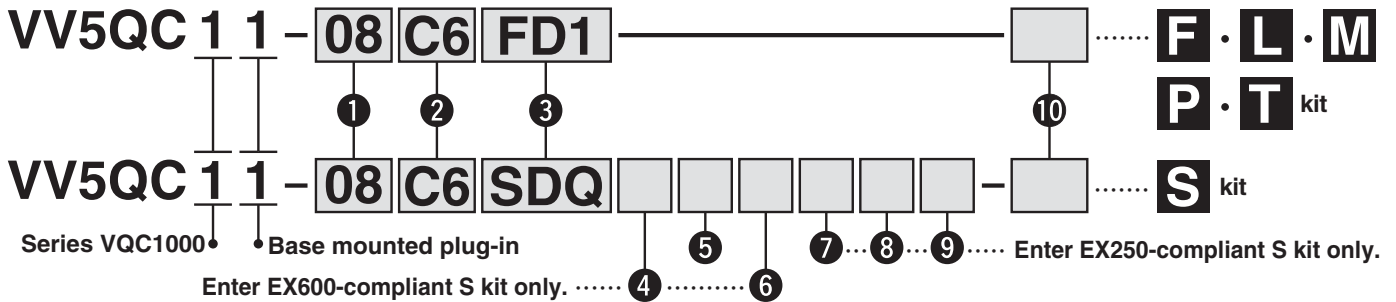

### 1 Stations

01	1 station
⋮	⋮

The maximum number of stations differs depending on the electrical entry. (Refer to 9 Kit type/Electrical entry/Cable length.)

Note) In case of compatibility with the S kit/AS-Interface, the maximum number of solenoids is as shown below, so please be careful of the number of stations.

- 8 in/8 out: Maximum 8 solenoids
- 4 in/4 out: Maximum 4 solenoids

### 2 Cylinder port size

C3	With ø3.2 one-touch fitting
C4	With ø4 one-touch fitting
C6	With ø6 one-touch fitting
M5	M5 thread
CM	Mixed sizes and with port plug
L3	Top ported elbow with ø3.2 one-touch fitting
L4	Top ported elbow with ø4 one-touch fitting
L6	Top ported elbow with ø6 one-touch fitting
L5	M5 thread
B3	Bottom ported elbow with ø3.2 one-touch fitting
B4	Bottom ported elbow with ø4 one-touch fitting
B6	Bottom ported elbow with ø6 one-touch fitting
B5	M5 thread
LM	Elbow port, mixed sizes
MM <sup>Note 2)</sup>	Mixed size for different types of piping, option installed

Note 1) Indicate the size by means of the manifold specification sheet in case of "CM", "LM", "NM".

Note 2) When selecting the mixed size for different types of piping or dual flow fitting assembly, enter "MM" and give instructions in the manifold specification sheet.

Note 3) Symbols for inch sizes are as follows:  
 • N1: ø1/8"      • N3: ø5/32"  
 • N7: ø1/4"      • NM: Mixed  
 The top ported elbow is LN□ and the bottom ported elbow is BN□.

### 5 SI unit COM

SI unit COM	EX250 integrated-type (I/O) serial transmission system					
	DeviceNet™	PROFIBUS DP	CC-Link	AS-Interface	CANopen	EtherNet/IP™
— + COM	—	—	○	—	—	—
N - COM	○	○	—	○	○	○

SI unit COM	EX500 gateway-type serial transmission system			EX260 integrated-type (for output) serial transmission system				EX126 integrated-type (for output) serial transmission system		
	DeviceNet™	PROFIBUS DP	EtherNet/IP™	DeviceNet™	PROFIBUS DP	CC-Link	EtherCAT	PROFINET	EtherNet/IP™	CC-Link
— + COM	○	○	○	○	○	○	○	○	○	○
N - COM	○	○	○	○	○	○	○	○	○	—

SI unit COM	EX600 integrated-type (I/O) serial transmission system (Fieldbus system)					
	DeviceNet™	PROFIBUS DP	CC-Link	EtherNet/IP™	EtherCAT	PROFINET
— + COM	○	○	○	○	○	○
N - COM	○	○	○	○	○	○

Note) Without SI unit (SD0□), the symbol is nil.

### 4 End plate type

(Enter EX600-compliant S kit only.)

—	Without end plate
2	M12 connector power supply (Max. supply current 2A)
3	7/8 inch connector power supply (Max. supply current 8A)

Note) Without SI unit, the symbol is nil.

### 6 I/O unit stations

(Enter EX600-compliant S kit only.)

—	None
1	1 station
⋮	⋮
9	9 stations

Note 1) Without SI unit, the symbol is nil.

Note 2) SI unit is not included in I/O unit stations.

Note 3) When I/O unit is selected, it is shipped separately, and assembled by customer. Refer to the attached operation manual for mounting method.

### 7 Number of input blocks

(Enter EX250-compliant S kit only.)

—	Without SI unit/input block (SD0)
0	Without input block
1	With 1 input block
⋮	⋮
8	With 8 input blocks

Note) For the S kit compatible with AS-Interface, the maximum number of stations is limited. Refer to page 6 for details.

### 8 Input block type

(Enter EX250-compliant S kit only.)

—	Without input block
1	M12, 2 inputs
2	M12, 4 inputs
3	M8, 4 inputs (3 pins)

### 9 Input block specification

(Enter EX250-compliant S kit only.)

—	PNP sensor input (+ COM) or without input block
N	NPN sensor input (- COM)

### 10 Option

—	None
B <sup>Note 2)</sup>	All stations with back pressure check valve
D	With DIN rail (Rail length: Standard)
D□ <sup>Note 3)</sup>	With DIN rail (Rail length: Special)
K <sup>Note 4)</sup>	Special wiring spec. (Except double wiring)
N <sup>Note 5)</sup>	With name plate
R <sup>Note 5)</sup>	External pilot
S <sup>Note 6)</sup>	Direct EXH outlet with built-in silencer

Note 1) When two or more symbols are specified, indicate them alphabetically. Example: -BRS

Note 2) When a back pressure check valve is desired, and is to be installed only in certain manifold stations, specify the mounting position by means of the manifold specification sheet.

Note 3) For special DIN rail length, indicate "D□". (Enter the number of stations inside □.) Example: -D08

In this case, stations will be mounted on a DIN rail for 8 stations regardless of the actual number of manifold stations.

The specified number of stations must be larger than the number of stations on the manifold. Indicate "-D0" for the option without DIN rail.

Note 4) When single wiring and double wiring are mixed, specify wiring type of each station by means of the manifold specification sheet.

Note 5) For external pilot option, "-R", indicate the external pilot specification "R" for the applicable valves as well.

Note 6) Built-in silencer type does not satisfy IP67.

Note 7) When changing the specifications of the EX600 from no DIN rail to DIN rail mounting, please consult SMC.

Note 8) When the EX600 "Without SI unit (SD60)" is specified, "With DIN rail (D)" cannot be selected.

Note 9) DIN rail is not attached (but shipped together) on the manifold in case of the EX600 with DIN rail. Refer to back page 57 for mounting method.

Note 10) When mounting the blanking plate with connector and the slide locking manual type valve by ordering only the manifold, order the name plate separately. For details, refer to page 50.

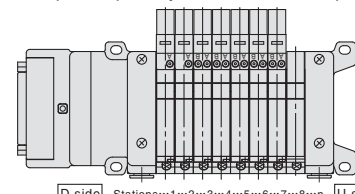

\* Stations are counted from station 1 on the D-side.

**3 Kit type/Electrical entry/Cable length**

\* Numbers in parentheses represent the maximum number of solenoids in case of mixed single and double wiring. The maximum number of stations is determined by the total number of solenoids. When ordering mixed wiring, please add the option symbol "K".

**S** kit  
(Serial transmission:  
EX500 gateway-type)

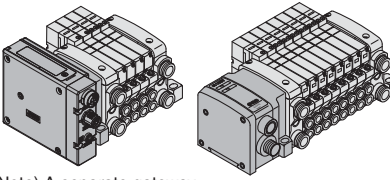

Note) A separate gateway unit and communication cable are required.

IP67 compliant

SI unit: **EX500**

<b>SD0</b>	Without SI unit	—	—
<b>SDA3</b>	EX500 Gateway Decentralized System 2 (128 points) EtherNet/IP™	32 outputs (Note 1)	1 to 12 stations (24)
<b>SDA2</b>	EX500 Gateway Decentralized System (64 points) DeviceNet™, PROFIBUS DP, EtherNet/IP™	16 outputs	1 to 8 stations (16)

**S** kit  
(Serial transmission  
(Fieldbus system):  
EX600 integrated-type (I/O))

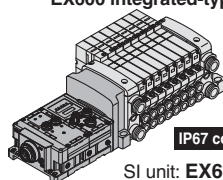

IP67 compliant

SI unit: **EX600**

<b>SD60</b>	Without SI unit	1 to 12 stations (24)
<b>SD6Q</b>	DeviceNet™	
<b>SD6N</b>	PROFIBUS DP	
<b>SD6V</b>	CC-Link	
<b>SD6F</b>	PROFINET	
<b>SD6ZE</b>	EtherNet/IP™ (1 port)	
<b>SD6EA</b>	EtherNet/IP™ (2 port)	
<b>SD6D</b>	EtherCAT	

**S** kit  
(Serial transmission:  
EX250 integrated-type (I/O))

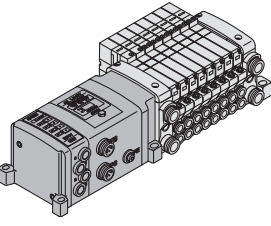

IP67 compliant

SI unit: **EX250**

<b>SD0</b>	Without SI unit	1 to 12 stations (24)
<b>SDQ</b>	DeviceNet™	
<b>SDN</b>	PROFIBUS DP	
<b>SDV</b>	CC-Link	1 to 4 stations (8)
<b>SDTA</b>	AS-Interface, 8 in/8 out, 31 slave modes, 2 power supply systems	
<b>SDTB</b>	AS-Interface, 4 in/4 out, 31 slave modes, 2 power supply systems	1 to 2 stations (4)
<b>SDTC</b>	Note 2) AS-Interface, 8 in/8 out, 31 slave modes, 1 power supply systems	1 to 4 stations (8)
<b>SDTD</b>	Note 2) AS-Interface, 4 in/4 out, 31 slave modes, 1 power supply systems	1 to 2 stations (4)
<b>SDY</b>	CANopen	1 to 12 stations (24)
<b>SDZEN</b>	EtherNet/IP™	(24)

**S** kit  
(Serial transmission:  
EX260 integrated-type (for output))

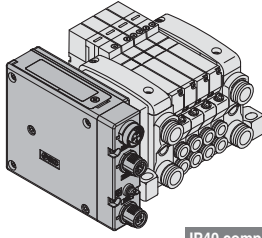

IP40 compliant

IP67 compliant

SI unit: **EX260**

Symbol	Protocol	Number of outputs	Communication connector	Stations
<b>SD0</b>		Without SI unit		2 to 12 stations (24)
<b>SQA</b>	DeviceNet™	32	M12	2 to 8 stations (16)
<b>SQB</b>		16		
<b>SNA</b>	PROFIBUS DP	32	M12	2 to 12 stations (24)
<b>SNB</b>		16		2 to 8 stations (16)
<b>SNC</b>		32	D-sub Note 4)	2 to 12 stations (24)
<b>SND</b>		16		2 to 8 stations (16)
<b>SVA</b>	CC-Link	32	M12	2 to 12 stations (24)
<b>SVB</b>		16		2 to 8 stations (16)
<b>SDA</b>	EtherCAT	32	M12	2 to 12 stations (24)
<b>SDB</b>		16		2 to 8 stations (16)
<b>SFA</b>	PROFINET	32	M12	2 to 12 stations (24)
<b>SFB</b>		16		2 to 8 stations (16)
<b>SEA</b>	EtherNet/IP™	32	M12	2 to 12 stations (24)
<b>SEB</b>		16		2 to 8 stations (16)

**S** kit  
(Serial transmission:  
EX126 integrated-type (for output))

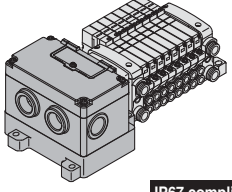

IP67 compliant

SI unit: **EX126**

<b>SDVB</b>	CC-Link	1 to 8 stations (16)
-------------	---------	----------------------

**F** kit  
(D-sub connector)

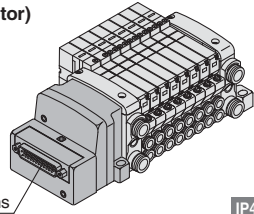

25 pins

IP40 compliant

<b>FD0</b>	D-sub connector (25P) without cable	1 to 12 stations (24)
<b>FD1</b>	D-sub connector (25P) with 1.5 m cable	
<b>FD2</b>	D-sub connector (25P) with 3.0 m cable	
<b>FD3</b>	D-sub connector (25P) with 5.0 m cable	

**P** kit  
(Flat ribbon cable)

Note) For a 20P flat ribbon cable, the cable assembly must be ordered separately.

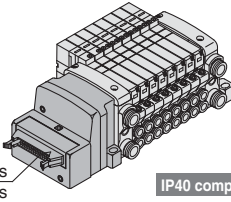

26 pins  
20 pins

IP40 compliant

<b>PD0</b>	Flat ribbon cable (26P) without cable	1 to 12 stations (24)
<b>PD1</b>	Flat ribbon cable (26P) with 1.5 m cable	
<b>PD2</b>	Flat ribbon cable (26P) with 3.0 m cable	
<b>PD3</b>	Flat ribbon cable (26P) with 5.0 m cable	1 to 9 stations (18)
<b>PDC</b>	Flat ribbon cable (20P) without cable	

**T** kit  
(Terminal block box)

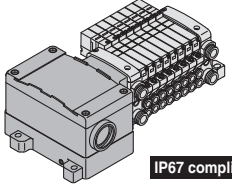

IP67 compliant

<b>TD0</b>	Terminal block box	1 to 10 stations (20)
------------	--------------------	-----------------------

**L** kit  
(Lead wire)

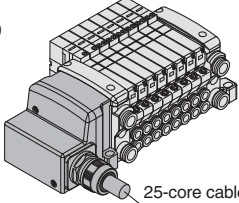

25-core cable

IP67 compliant

<b>LD0</b>	Lead wire (25 cores) 0.6 m lead wire	1 to 12 stations (24)
<b>LD1</b>	Lead wire (25 cores) 1.5 m lead wire	
<b>LD2</b>	Lead wire (25 cores) 3.0 m lead wire	

**M** kit  
(Circular connector)

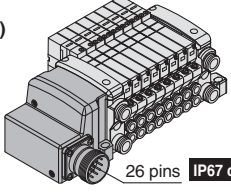

26 pins

IP67 compliant

<b>MD0</b>	Circular connector (26P) without cable	1 to 12 stations (24)
<b>MD1</b>	Circular connector (26P) with 1.5 m cable	
<b>MD2</b>	Circular connector (26P) with 3.0 m cable	
<b>MD3</b>	Circular connector (26P) with 5.0 m cable	

\* The maximum number of stations displayed in parentheses is applied to the special wiring specifications. (Option "K")  
 Note 1) When using the SI unit with 32 outputs, use the GW unit compatible with the EX500 Gateway Decentralized System 2 (128 points).  
 Note 2) When selecting SI units with SDTC or SDTD specifications, there are limits to the supply current from the SI unit to the input block or valve.  
 Note 3) When selecting SI units with SDZCN specifications only, IP40 is compatible. (All other SI units are IP67 compliant.)  
 Note 4) For the SI unit part no., refer to page 7.

# Series VQC1000

## SI Unit Part No.

### EX500 Gateway Decentralized System 2 (128 points)

Symbol	Compatible protocol	SI unit part no.		Page
		Negative common (PNP)		
<b>SDA3</b>	EtherNet/IP™	EX500-S103		P.46

### EX500 Gateway Decentralized System (64 points)

Symbol	Compatible protocol	SI unit part no.		Page
		Positive common (NPN)	Negative common (PNP)	
<b>SDA2</b>	DeviceNet™	EX500-Q001	EX500-Q101	P.46
	PROFIBUS DP			
	EtherNet/IP™			

### EX600

Symbol	Compatible protocol	SI unit part no.		Page
		Positive common (NPN)	Negative common (PNP)	
<b>SD6Q</b>	DeviceNet™	EX600-SDN2A	EX600-SDN1A	P.46
<b>SD6V</b>	CC-Link	EX600-SMJ2	EX600-SMJ1	
<b>SD6N</b>	PROFIBUS DP	EX600-SPR2A	EX600-SPR1A	
<b>SD6F</b>	PROFINET	EX600-SPN2	EX600-SPN1	
<b>SD6ZE</b>	EtherNet/IP™ (1 port)	EX600-SEN2	EX600-SEN1	
<b>SD6EA</b>	EtherNet/IP™ (2 port)	EX600-SEN4	EX600-SEN3	
<b>SD6D</b>	EtherCAT	EX600-SEC2	EX600-SEC1	

### EX260

Symbol	Compatible protocol	Number of outputs	SI unit part no.		Communication connector	Page
			Positive common (NPN)	Negative common (PNP)		
<b>SQA</b>	DeviceNet™	32	EX260-SDN2	EX260-SDN1	M12	P.47
<b>SQB</b>		16	EX260-SDN4	EX260-SDN3		
<b>SNA</b>	PROFIBUS DP	32	EX260-SPR2	EX260-SPR1	D-sub (Note)	
<b>SNB</b>		16	EX260-SPR4	EX260-SPR3		
<b>SNC</b>		32	EX260-SPR6	EX260-SPR5		
<b>SND</b>		16	EX260-SPR8	EX260-SPR7		
<b>SVA</b>	CC-Link	32	EX260-SMJ2	EX260-SMJ1	M12	
<b>SVB</b>		16	EX260-SMJ4	EX260-SMJ3		
<b>SDA</b>	EtherCAT	32	EX260-SEC2	EX260-SEC1	M12	
<b>SDB</b>		16	EX260-SEC4	EX260-SEC3		
<b>SFA</b>	PROFINET	32	EX260-SPN2	EX260-SPN1	M12	
<b>SFB</b>		16	EX260-SPN4	EX260-SPN3		
<b>SEA</b>	EtherNet/IP™	32	EX260-SEN2	EX260-SEN1	M12	
<b>SEB</b>		16	EX260-SEN4	EX260-SEN3		

Note) When the communication connector specification is D-sub, the enclosure is IP40. (IP67 for other specifications)

### EX250

Symbol	Compatible protocol	SI unit part no.	Page
<b>SDQ</b>	DeviceNet™	EX250-SDN1	P.47
<b>SDN</b>	PROFIBUS DP	EX250-SPR1	
<b>SDV</b>	CC-Link	EX250-SMJ2	
<b>SDTA</b>	AS-Interface, 8 in/8 out, 31 slave modes, 2 power supply systems	EX250-SAS3	
<b>SDTB</b>	AS-Interface, 4 in/4 out, 31 slave modes, 2 power supply systems	EX250-SAS5	
<b>SDTC</b>	AS-Interface, 8 in/8 out, 31 slave modes, 1 power supply systems	EX250-SAS7	
<b>SDTD</b>	AS-Interface, 4 in/4 out, 31 slave modes, 1 power supply systems	EX250-SAS9	
<b>SDY</b>	CANopen	EX250-SCA1A	
<b>SDZEN</b>	EtherNet/IP™	EX250-SEN1	

### EX126

Symbol	Compatible protocol	SI unit part no.	Page
<b>SDVB</b>	CC-Link	EX126D-SMJ1	P.47

For details about the EX series (Serial transmission system), refer to the **WEB catalogue** and the Operation Manual.

### How to Order Valves

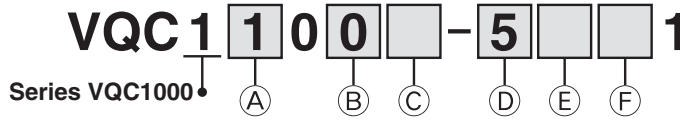

#### A Type of actuation

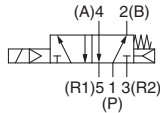
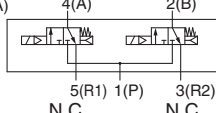
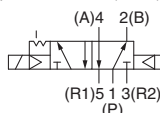
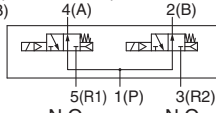
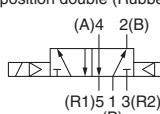
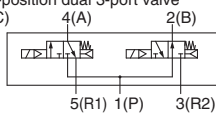
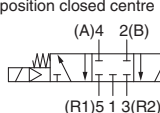
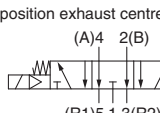
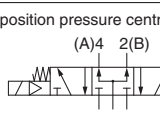
<b>1</b>	2-position single 	Note) <b>A</b> 4-position dual 3-port valve (A) 
<b>2</b>	2-position double (Metal) 	Note) <b>B</b> 4-position dual 3-port valve (B) 
	2-position double (Rubber) 	Note) <b>C</b> 4-position dual 3-port valve (C) 
<b>3</b>	3-position closed centre 	Note) Rubber seal only
<b>4</b>	3-position exhaust centre 	
<b>5</b>	3-position pressure centre 	

#### B Seal

0	Metal seal
1	Rubber seal

#### C Function

—	Standard (0.4 W)
B	High-speed response type (0.95 W)
K <small>Note 1)</small>	High-pressure type (1.0 MPa, 0.95 W)
N <small>Note 2)</small>	Negative common
R <small>Note 3)</small>	External pilot

\* When two or more symbols are specified, indicate them alphabetically. However, combination of "B" and "K" is not possible.  
 Note 1) Metal seal only  
 Note 2) When "-COM." is specified for the SI unit, select and mount the valve of negative common.  
 Note 3) Dual 3-port is not applicable.

#### D Coil voltage

5 <small>Note)</small>	24 VDC
6	12 VDC

Note) Only 24 VDC is available with the S kit.

#### E Light/surge voltage suppressor

—	Yes
E <small>Note 1, 2)</small>	None (Non-polar)

Note 1) Not applicable to the S kit.  
 Note 2) A combination of "Function N (Negative common)" and "E" is unavailable. Since "E" has no polarity, it can also be used as a negative common. Selection of "Function N" is not required.

#### F Manual override

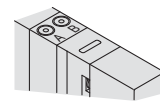
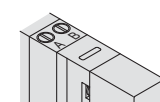
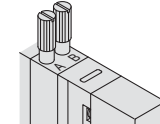
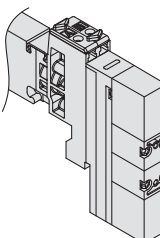
—	Non-locking push type (Tool required)	
B	Push-turn locking type (Tool required)	
C	Turn locking type (Manual)	
D	Slide locking type (Manual)	

### How to Order Manifold Assembly

#### Example

**Manifold**  
 Power supply with M12 connector

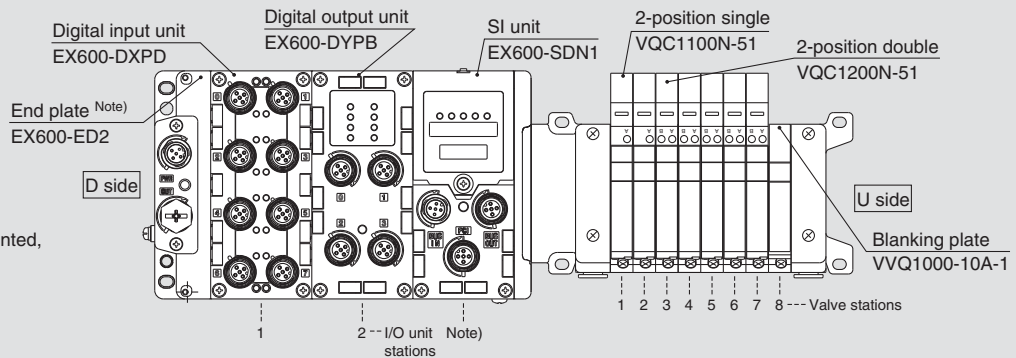

For the I/O unit part number mounted, refer to catalog CAT.EU02-24.

- Digital unit
- Analogue unit

#### Serial transmission kit

- |                     |              |                                     |
|---------------------|--------------|-------------------------------------|
| VV5QC11-08C6SD6Q2N2 | ..... 1 set  | Manifold base part number           |
| * VQC1100N-51       | ..... 2 sets | Valve part number (Stations 1 to 2) |
| * VQC1200N-51       | ..... 5 sets | Valve part number (Stations 3 to 7) |
| * VVQ1000-10A-1     | ..... 1 set  | Blanking plate number (Station 8)   |
| * EX600-DXPD        | ..... 1 set  | I/O unit part number (Station 1)    |
| * EX600-DYPB        | ..... 1 set  | I/O unit part number (Station 2)    |

Enter in order starting from the first station on the D-side. When entry of part numbers becomes complicated, indicate with the manifold specification sheet.

Enter in order starting from the first station on the U-side. When entry of part numbers becomes complicated, indicate with the manifold specification sheet.

Note) Do not enter the SI unit part number and the end plate part number together.

The asterisk denotes the symbol for assembly. Prefix it to the part nos. of the solenoid valve, etc.



# Series VQC1000

## Manifold Options

Refer to pages 49 through to 52 for details.

**Blanking plate assembly**  
VVQ1000-10A-1

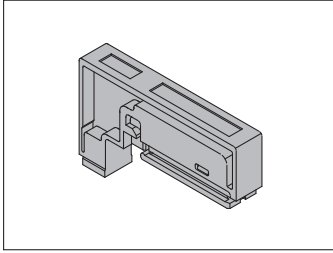

**Individual SUP spacer**  
VVQ1000-P-1-C6-N7

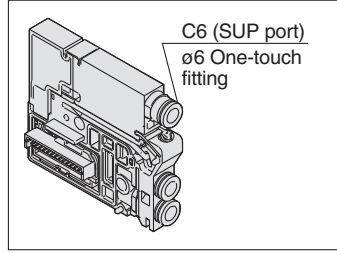

**Individual EXH spacer**  
VVQ1000-R-1-C6-N7

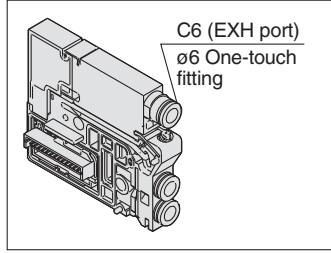

**SUP block plate**  
VVQ1000-16A

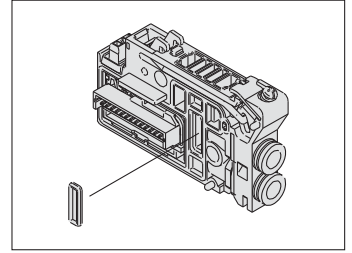

**Blanking plate with connector**  
VVQ1000-1C-□-□

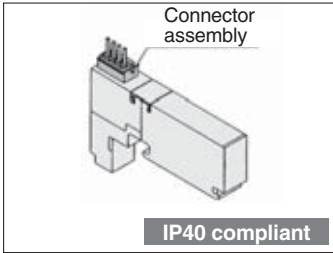

**EXH block plate assembly**  
VVQC1000-19A-S-C3, C4, C6, M5, N1, N3, N7

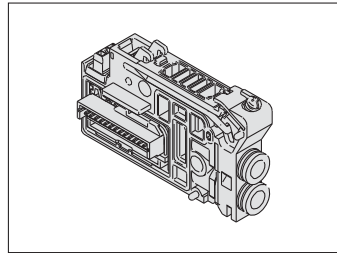

**Back pressure check valve assembly [-B]**  
VVQ1000-18A

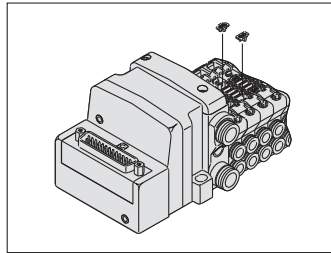

**Name plate [-N]**  
VVQ1000-N-NC-(1 to Max. stations) (-X4)

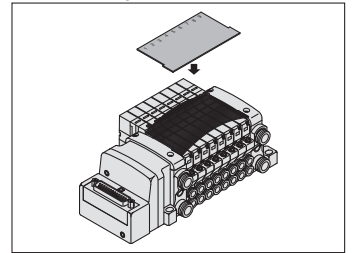

**Blanking plug**  
KQ2P-□

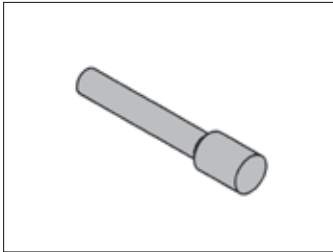

**Port plug**  
VVQ0000-58A

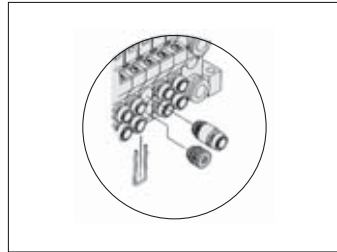

**Elbow fitting assembly**  
VVQ1000-F-L-□

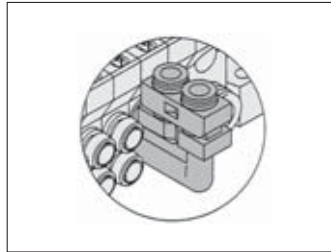

**DIN rail mounting bracket [-D]**  
VVQ1000-57A  
{For F/L/M/P/S (EX500) kit}  
VVQC1000-57A-S  
{For S (EX250) kit}  
VVQC1000-57A-T (For T kit)

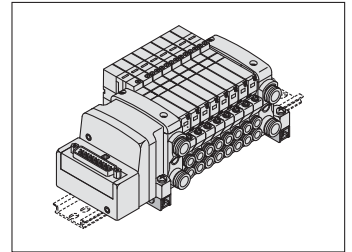

**Direct EXH outlet with built-in silencer [-S]**

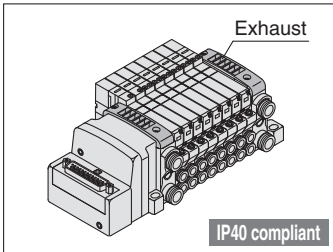

**Dual flow fitting assembly**  
VVQ1000-52A-C8-N9

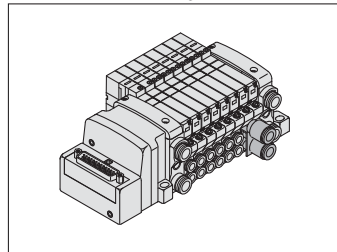

**Special electrical wiring specifications [-K]**

Wiring example)  
D-sub connector

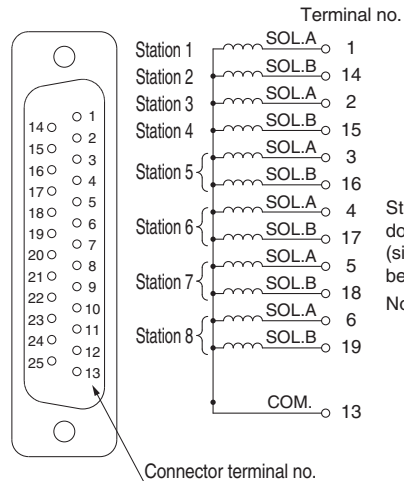

Standard manifolds are for double wiring, but mixed wiring (single and double wiring) can be specified as an option.

Note) Refer to the pages of each kit for details.

F kit ..... P. 33

P kit ..... P. 35

T kit ..... P. 37

L kit ..... P. 39

M kit ..... P. 41

**Silencer (For EXH port)**  
AN15-C08

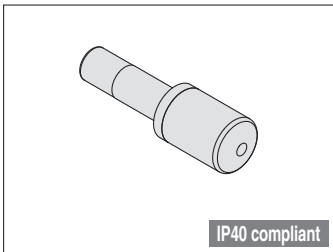

**Double check block**  
VVQ1000-FPG-□-□-□

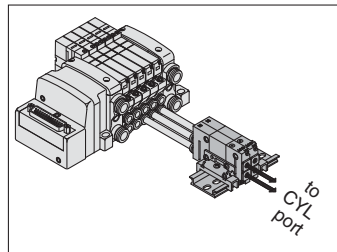





# Base Mounted Plug-in Unit Series VQC2000

## How to Order Manifold

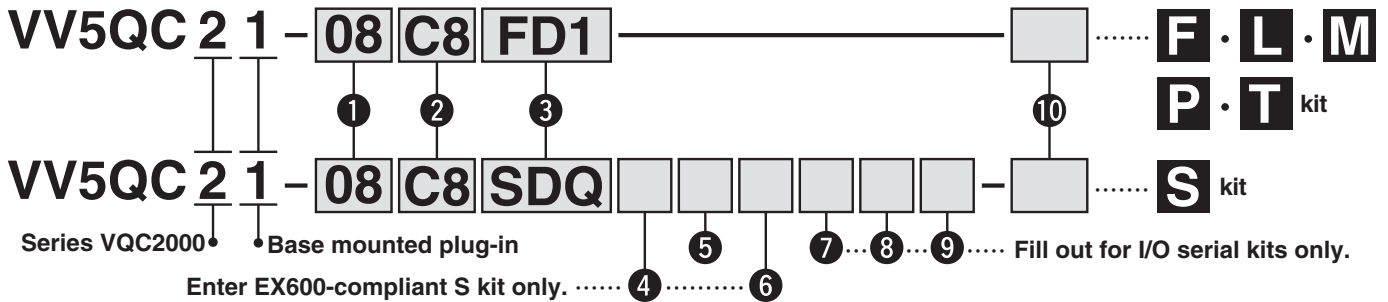

### 1 Stations

01	1 station
⋮	⋮

The maximum number of stations differs depending on the electrical entry. (Refer to 9 Kit type/Electrical entry/Cable length.)

Note) In case of compatibility with the S kit/AS-Interface, the maximum number of solenoids is as shown below, so please be careful of the number of stations.

- 8 in/8 out: Maximum 8 solenoids
- 4 in/4 out: Maximum 4 solenoids

### 2 Cylinder port size

C4	With $\phi 4$ one-touch fitting
C6	With $\phi 6$ one-touch fitting
C8	With $\phi 8$ one-touch fitting
CM	Mixed sizes and with port plug
L4	Top ported elbow with $\phi 4$ one-touch fitting
L6	Top ported elbow with $\phi 6$ one-touch fitting
L8	Top ported elbow with $\phi 8$ one-touch fitting
B4	Bottom ported elbow with $\phi 4$ one-touch fitting
B6	Bottom ported elbow with $\phi 6$ one-touch fitting
B8	Bottom ported elbow with $\phi 8$ one-touch fitting
LM	Elbow port, mixed sizes
MM <sup>Note 2)</sup>	Mixed size for different types of piping, option installed

Note 1) Indicate the size by means of the manifold specification sheet in case of "CM", "LM", "NM".

Note 2) When selecting the mixed size for different types of piping or dual flow fitting assembly, enter "MM" and give instructions in the manifold specification sheet.

Note 3) Symbols for inch sizes are as follows:

- N3:  $\phi 5/32"$       • N7:  $\phi 1/4"$
  - N9:  $\phi 5/16"$       • NM: Mixed
- The top ported elbow is LN□ and the bottom ported elbow is BN□.

### 5 SI unit COM

SI unit COM	EX250 integrated-type (I/O) serial transmission system					
	DeviceNet™	PROFIBUS DP	CC-Link	AS-Interface	CANopen	EtherNet/IP™
— + COM	—	—	○	—	—	—
N - COM	○	○	—	○	○	○

SI unit COM	EX500 gateway-type serial transmission system			EX260 integrated-type (for output) serial transmission system				EX126 integrated-type (for output) serial transmission system		
	DeviceNet™	PROFIBUS DP	EtherNet/IP™	DeviceNet™	PROFIBUS DP	CC-Link	EtherCAT	PROFINET	EtherNet/IP™	CC-Link
— + COM	○	○	○	○	○	○	○	○	○	○
N - COM	○	○	○	○	○	○	○	○	○	—

SI unit COM	EX600 integrated-type (I/O) serial transmission system (Fieldbus system)					
	DeviceNet™	PROFIBUS DP	CC-Link	EtherNet/IP™	EtherCAT	PROFINET
— + COM	○	○	○	○	○	○
N - COM	○	○	○	○	○	○

Note) Without SI unit (SD0□), the symbol is nil.

### 4 End plate type

(Enter EX600-compliant S kit only.)

—	Without end plate
2	M12 connector power supply (Max. supply current 2A)
3	7/8 inch connector power supply (Max. supply current 8A)

Note) Without SI unit, the symbol is nothing.

### 6 I/O unit stations

(Enter EX600-compliant S kit only.)

—	None
1	1 station
⋮	⋮
9	9 stations

Note 1) Without SI unit, the symbol is nothing.

Note 2) SI unit is not included in I/O unit stations.

Note 3) When I/O unit is selected, it is shipped separately, and assembled by customer. Refer to the attached operation manual for mounting method.

### 7 Number of input blocks

(Enter EX250-compliant S kit only.)

—	Without SI unit/input block (SD0)
0	Without input block
1	With 1 input block
⋮	⋮
8	With 8 input blocks

Note) For the S kit compatible with AS-Interface, the maximum number of stations is limited. Refer to page 10 for details.

### 8 Input block type

(Enter EX250-compliant S kit only.)

—	Without input block
1	M12, 2 inputs
2	M12, 4 inputs
3	M8, 4 inputs (3 pins)

### 9 Input block specification

(Enter EX250-compliant S kit only.)

—	PNP sensor input (+ COM) or without input block
N	NPN sensor input (- COM)

### 10 Option

—	None
B <sup>Note 2)</sup>	All stations with back pressure check valve
D	With DIN rail (Rail length: Standard) <sup>Note 9)</sup>
D□ <sup>Note 4)</sup>	With DIN rail (Rail length: Special) <sup>Note 9)</sup>
K <sup>Note 5)</sup>	Special wiring spec. (Except double wiring)
N <sup>Note 12)</sup>	With name plate
R <sup>Note 6)</sup>	External pilot
S <sup>Note 7)</sup>	Direct EXH outlet with built-in silencer
T <sup>Note 8)</sup>	Branched P and R ports on U-side

Note 1) When two or more symbols are specified, indicate them alphabetically. Example: -BRS

Note 2) When a back pressure check valve is desired, and is to be installed only in certain manifold stations, specify the mounting position by means of the manifold specification sheet.

Note 3) When DIN rail mounting (with DIN rail) is selected with a power supply 7/8 inch connector for end plate of the VQC2000 series, and I/O unit station number is 9, and max. valve station number is 23. DIN rail mount cannot be specified for 24 stations. (Refer to the DIN rail full length on page 26.)

Note 4) For special DIN rail length, indicate "D□". (Enter the number of stations inside □.) Example: -D08

In this case, stations will be mounted on a DIN rail for 8 stations regardless of the actual number of manifold stations.

The specified number of stations must be larger than the number of stations on the manifold.

Indicate "-D0" for the option without DIN rail.

Note 5) When single wiring and double wiring are mixed, specify wiring type of each station by means of the manifold specification sheet.

Note 6) For external pilot option, "-R", indicate the external pilot specification "R" for the applicable valves as well.

Note 7) Built-in silencer type does not satisfy IP67.

Note 8) SUP and EXH ports on the U-side (on cylinder port side and coil side is branched.) Port is equipped with one-touch fitting for  $\phi 12$ .

Note 9) When changing the specifications of the EX600 from no DIN rail to DIN rail mounting, please consult SMC.

Note 10) When the EX600 "Without SI unit (SD60)" is specified, "With DIN rail (D)" cannot be selected.

Note 11) DIN rail is not attached (but shipped together) on the manifold in case of the EX600 with DIN rail. Refer to back page 57 for mounting method.

Note 12) When mounting the blanking plate with connector and the slide locking manual type valve by ordering only the manifold, order the name plate separately. For details, refer to page 50.

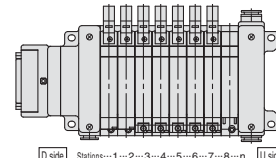

\* Stations are counted from station 1 on the D-side.

**3 Kit type/Electrical entry/Cable length**

\* Numbers in parentheses represent the maximum number of solenoids in case of mixed single and double wiring. The maximum number of stations is determined by the total number of solenoids. When ordering mixed wiring, please add the option symbol "K".

**S** kit  
(Serial transmission:  
EX500 gateway-type)

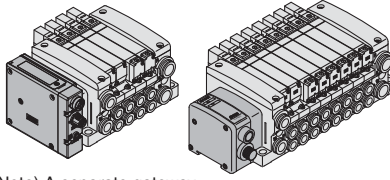

Note) A separate gateway unit and communication cable are required.

IP67 compliant

SI unit: **EX500**

<b>SD0</b>	Without SI unit	—	—
<b>SDA3</b>	EX500 Gateway Decentralized System 2 (128 points) EtherNet/IP™	32 outputs (Note 1)	1 to 12 stations (24)
<b>SDA2</b>	EX500 Gateway Decentralized System (64 points) DeviceNet™, PROFIBUS DP, EtherNet/IP™	16 outputs	1 to 8 stations (16)

**S** kit  
(Serial transmission  
(Fieldbus system):  
EX600 integrated-type (I/O))

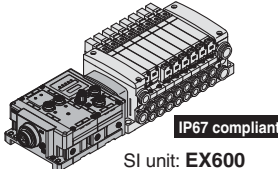

IP67 compliant

SI unit: **EX600**

<b>SD60</b>	Without SI unit	1 to 12 stations (24)
<b>SD6Q</b>	DeviceNet™	
<b>SD6N</b>	PROFIBUS DP	
<b>SD6V</b>	CC-Link	
<b>SD6F</b>	PROFINET	
<b>SD6ZE</b>	EtherNet/IP™ (1 port)	
<b>SD6EA</b>	EtherNet/IP™ (2 port)	
<b>SD6D</b>	EtherCAT	

**S** kit  
(Serial transmission:  
EX250 integrated-type (I/O))

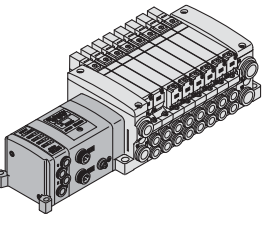

IP67 compliant

SI unit: **EX250**

<b>SD0</b>	Without SI unit	1 to 12 stations (24)
<b>SDQ</b>	DeviceNet™	
<b>SDN</b>	PROFIBUS DP	
<b>SDV</b>	CC-Link	
<b>SDTA</b>	AS-Interface, 8 in/8 out, 31 slave modes, 2 power supply systems	1 to 4 stations (8)
<b>SDTB</b>	AS-Interface, 4 in/4 out, 31 slave modes, 2 power supply systems	1 to 2 stations (4)
Note 2) <b>SDTC</b>	AS-Interface, 8 in/8 out, 31 slave modes, 1 power supply systems	1 to 4 stations (8)
Note 2) <b>SDTD</b>	AS-Interface, 4 in/4 out, 31 slave modes, 1 power supply systems	1 to 2 stations (4)
<b>SDY</b>	CANopen	1 to 12 stations (24)
<b>SDZEN</b>	EtherNet/IP™	(24)

**S** kit  
(Serial transmission:  
EX260 integrated-type (for output))

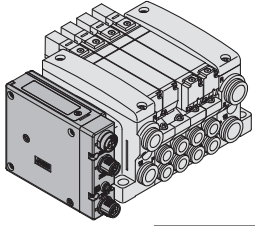

IP40 compliant

IP67 compliant

SI unit: **EX260**

Symbol	Protocol	Number of outputs	Communication connector	Stations
<b>SD0</b>		Without SI unit		2 to 12 stations (24)
<b>SQA</b>	DeviceNet™	32	M12	
<b>SQB</b>		16		
<b>SNA</b>	PROFIBUS DP	32	M12	2 to 12 stations (24)
<b>SNB</b>		16		2 to 8 stations (16)
<b>SNC</b>		32	D-sub Note 4)	2 to 12 stations (24)
<b>SND</b>		16		2 to 8 stations (16)
<b>SVA</b>	CC-Link	32	M12	2 to 12 stations (24)
<b>SVB</b>		16		2 to 8 stations (16)
<b>SDA</b>	EtherCAT	32	M12	2 to 12 stations (24)
<b>SDB</b>		16		2 to 8 stations (16)
<b>SFA</b>	PROFINET	32	M12	2 to 12 stations (24)
<b>SFB</b>		16		2 to 8 stations (16)
<b>SEA</b>	EtherNet/IP™	32	M12	2 to 12 stations (24)
<b>SEB</b>		16		2 to 8 stations (16)

**S** kit  
(Serial transmission:  
EX126 integrated-type (for output))

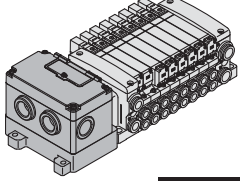

IP67 compliant

SI unit: **EX126**

<b>SDVB</b>	CC-Link	1 to 8 stations (16)
-------------	---------	----------------------

**F** kit  
(D-sub connector)

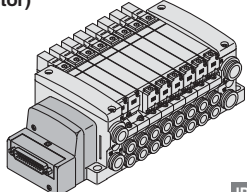

IP40 compliant

<b>FD0</b>	D-sub connector (25P) without cable	1 to 12 stations (24)
<b>FD1</b>	D-sub connector (25P) with 1.5 m cable	
<b>FD2</b>	D-sub connector (25P) with 3.0 m cable	
<b>FD3</b>	D-sub connector (25P) with 5.0 m cable	

**P** kit  
(Flat ribbon cable)

Note) For a 20P flat ribbon cable, the cable assembly must be ordered separately.

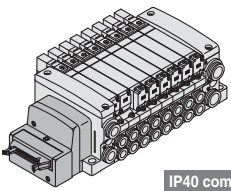

IP40 compliant

<b>PD0</b>	Flat ribbon cable (26P) without cable	1 to 12 stations (24)
<b>PD1</b>	Flat ribbon cable (26P) with 1.5 m cable	
<b>PD2</b>	Flat ribbon cable (26P) with 3.0 m cable	
<b>PD3</b>	Flat ribbon cable (26P) with 5.0 m cable	
<b>PDC</b>	Flat ribbon cable (20P) without cable	1 to 9 stations (18)

**T** kit  
(Terminal block box)

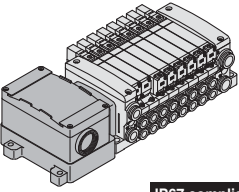

IP67 compliant

<b>TD0</b>	Terminal block box	1 to 10 stations (20)
------------	--------------------	-----------------------

**L** kit  
(Lead wire)

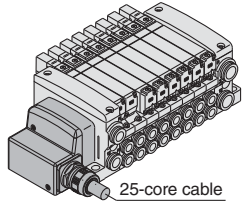

25-core cable

IP67 compliant

<b>LD0</b>	Lead wire (25 cores) 0.6 m lead wire	1 to 12 stations (24)
<b>LD1</b>	Lead wire (25 cores) 1.5 m lead wire	
<b>LD2</b>	Lead wire (25 cores) 3.0 m lead wire	
<b>LD3</b>	Lead wire (25 cores) 5.0 m lead wire	

**M** kit  
(Circular connector)

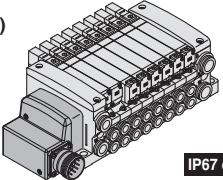

IP67 compliant

<b>MD0</b>	Circular connector (26P) without cable	1 to 12 stations (24)
<b>MD1</b>	Circular connector (26P) with 1.5 m cable	
<b>MD2</b>	Circular connector (26P) with 3.0 m cable	
<b>MD3</b>	Circular connector (26P) with 5.0 m cable	

\* The maximum number of stations displayed in parentheses is applied to the special wiring specifications. (Option "K")  
 Note 1) When using the SI unit with 32 outputs, use the GW unit compatible with the EX500 Gateway Decentralized System 2 (128 points).  
 Note 2) When selecting SI units with SDTC or SDTD specifications, there are limits to the supply current from the SI unit to the input block or valve.  
 Note 3) When selecting SI units with SDZCN specifications only, IP40 is compatible. (All other SI units are IP67 compliant.)  
 Note 4) For the SI unit part no., refer to page 13.

# Series VQC2000

## SI Unit Part No.

### EX500 Gateway Decentralized System 2 (128 points)

Symbol	Compatible protocol	SI unit part no.		Page
		Negative common (PNP)		
<b>SDA3</b>	EtherNet/IP™	EX500-S103		P.46

### EX500 Gateway Decentralized System (64 points)

Symbol	Compatible protocol	SI unit part no.		Page
		Positive common (NPN)	Negative common (PNP)	
<b>SDA2</b>	DeviceNet™	EX500-Q001	EX500-Q101	P.46
	PROFIBUS DP			
	EtherNet/IP™			

### EX600

Symbol	Compatible protocol	SI unit part no.		Page
		Positive common (NPN)	Negative common (PNP)	
<b>SD6Q</b>	DeviceNet™	EX600-SDN2A	EX600-SDN1A	P.46
<b>SD6V</b>	CC-Link	EX600-SMJ2	EX600-SMJ1	
<b>SD6N</b>	PROFIBUS DP	EX600-SPR2A	EX600-SPR1A	
<b>SD6F</b>	PROFINET	EX600-SPN2	EX600-SPN1	
<b>SD6ZE</b>	EtherNet/IP™ (1 port)	EX600-SEN2	EX600-SEN1	
<b>SD6EA</b>	EtherNet/IP™ (2 port)	EX600-SEN4	EX600-SEN3	
<b>SD6D</b>	EtherCAT	EX600-SEC2	EX600-SEC1	

### EX260

Symbol	Compatible protocol	Number of outputs	SI unit part no.		Communication connector	Page
			Positive common (NPN)	Negative common (PNP)		
<b>SQA</b>	DeviceNet™	32	EX260-SDN2	EX260-SDN1	M12	P.47
<b>SQB</b>		16	EX260-SDN4	EX260-SDN3		
<b>SNA</b>	PROFIBUS DP	32	EX260-SPR2	EX260-SPR1		
<b>SNB</b>		16	EX260-SPR4	EX260-SPR3		
<b>SNC</b>		32	EX260-SPR6	EX260-SPR5		
<b>SND</b>		16	EX260-SPR8	EX260-SPR7	D-sub Note)	
<b>SVA</b>	CC-Link	32	EX260-SMJ2	EX260-SMJ1	M12	
<b>SVB</b>		16	EX260-SMJ4	EX260-SMJ3		
<b>SDA</b>	EtherCAT	32	EX260-SEC2	EX260-SEC1	M12	
<b>SDB</b>		16	EX260-SEC4	EX260-SEC3		
<b>SFA</b>	PROFINET	32	EX260-SPN2	EX260-SPN1	M12	
<b>SFB</b>		16	EX260-SPN4	EX260-SPN3		
<b>SEA</b>	EtherNet/IP™	32	EX260-SEN2	EX260-SEN1	M12	
<b>SEB</b>		16	EX260-SEN4	EX260-SEN3		

Note) When the communication connector specification is D-sub, the enclosure is IP40. (IP67 for other specifications)

### EX250

Symbol	Compatible protocol	SI unit part no.	Page
<b>SDQ</b>	DeviceNet™	EX250-SDN1	P.47
<b>SDN</b>	PROFIBUS DP	EX250-SPR1	
<b>SDV</b>	CC-Link	EX250-SMJ2	
<b>SDTA</b>	AS-Interface, 8 in/8 out, 31 slave modes, 2 power supply systems	EX250-SAS3	
<b>SDTB</b>	AS-Interface, 4 in/4 out, 31 slave modes, 2 power supply systems	EX250-SAS5	
<b>SDTC</b>	AS-Interface, 8 in/8 out, 31 slave modes, 1 power supply systems	EX250-SAS7	
<b>SDTD</b>	AS-Interface, 4 in/4 out, 31 slave modes, 1 power supply systems	EX250-SAS9	
<b>SDY</b>	CANopen	EX250-SCA1A	
<b>SDZEN</b>	EtherNet/IP™	EX250-SEN1	

### EX126

Symbol	Compatible protocol	SI unit part no.	Page
<b>SDVB</b>	CC-Link	EX126D-SMJ1	P.47

For details about the EX series (Serial transmission system), refer to the **WEB catalogue** and the Operation Manual.



### How to Order Valves

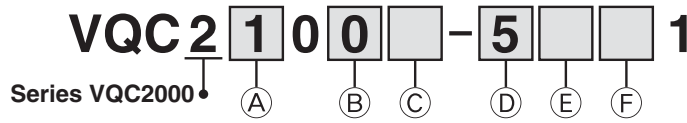

#### A Type of actuation

<b>1</b>	2-position single  (A)4 2(B) (R1)5 1 3(R2) (P)	<b>A</b>	4-position dual 3-port valve (A)  4(A) 2(B) 5(R1) 1(P) 3(R2) N.C. N.C.
	2-position double (Metal)  (A)4 2(B) (R1)5 1 3(R2) (P)		<b>B</b>
<b>2</b>	2-position double (Rubber)  (A)4 2(B) (R1)5 1 3(R2) (P)	<b>C</b>	
	3-position closed centre  (A)4 2(B) (R1)5 1 3(R2) (P)		Note) Rubber seal only
<b>3</b>	3-position exhaust centre  (A)4 2(B) (R1)5 1 3(R2) (P)		
<b>4</b>	3-position pressure centre  (A)4 2(B) (R1)5 1 3(R2) (P)		
<b>5</b>			

#### B Seal

0	Metal seal
1	Rubber seal

#### C Function

—	Standard (0.4 W)
B	High-speed response type (0.95 W)
K <small>Note 1)</small>	High-pressure type (1.0 MPa, 0.95 W)
N <small>Note 2)</small>	Negative common
R <small>Note 3)</small>	External pilot

\* When two or more symbols are specified, indicate them alphabetically. However, combination of "B" and "K" is not possible.

Note 1) Metal seal only

Note 2) When "-COM." is specified for the SI unit, select and mount the valve of negative common.

Note 3) Dual 3-port type is not applicable.

#### D Coil voltage

5 <small>Note)</small>	24 VDC
6	12 VDC

Note) Only 24 VDC is available with the S kit.

#### E Light/surge voltage suppressor

—	Yes
E <small>Note 1, 2)</small>	None (Non-polar)

Note 1) Not applicable to the S kit.

Note 2) A combination of "Function N (Negative common)" and "E" is unavailable.

Since "E" has no polarity, it can also be used as a negative common. Selection of "Function N" is not required.

#### F Manual override

—	Non-locking push type (Tool required)	
B	Push-turn locking type (Tool required)	
C	Turn locking type (Tool required)	
D	Slide locking type (Manual)	

### How to Order Manifold Assembly

#### Example

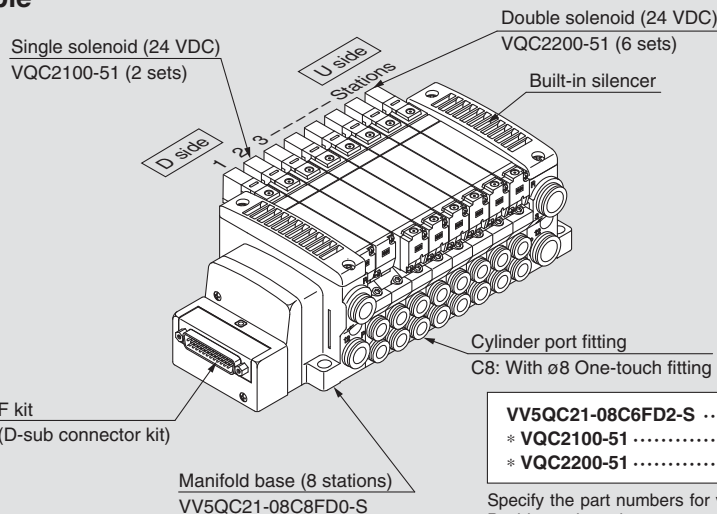

**VV5QC21-08C6FD2-S** ..... 1 set (F kit, built-in silencer 8-station manifold base part no.)  
 \* **VQC2100-51** ..... 2 sets (Single solenoid part no.)  
 \* **VQC2200-51** ..... 6 sets (Double solenoid part no.)

Specify the part numbers for valves and options together beneath the manifold base part number. Besides, when the arrangement will be complicated, specify them by means of the manifold specification sheet.

# Series VQC2000

## Manifold Options Refer to pages 49 through to 52 for details.

**Blanking plate assembly**  
VVQ2000-10A-1

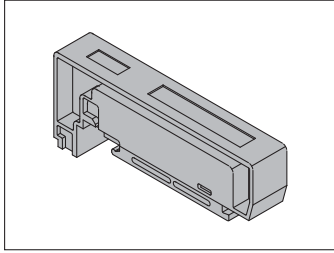

**Individual SUP spacer**  
VVQ2000-P-1-C8  
N9

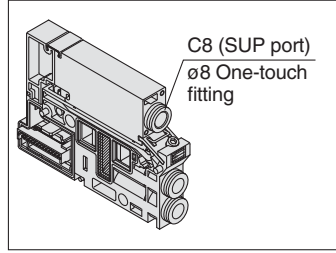

**Individual EXH spacer**  
VVQ2000-R-1-C8  
N9

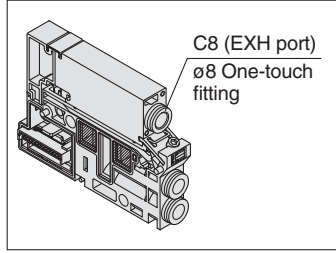

**SUP block plate**  
VVQ2000-16A

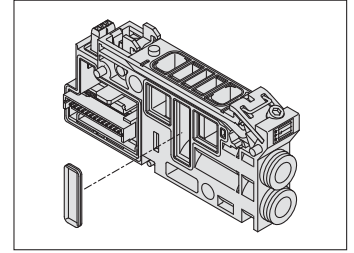

**EXH block plate**  
VVQ2000-19A

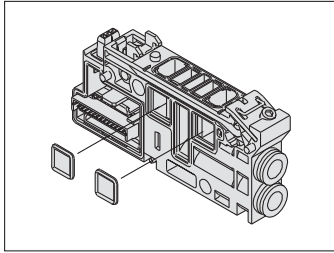

**Back pressure check valve assembly [-B]**  
VVQ2000-18A

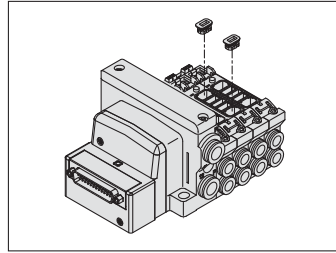

**Name plate [-N]**  
VVQ2000-N-(1 to Max. stations) (-X4)

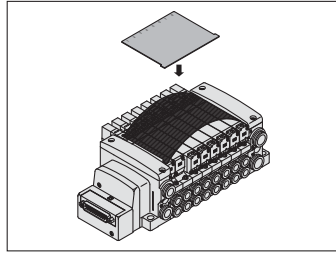

**Blanking plug**  
KQ2P-□

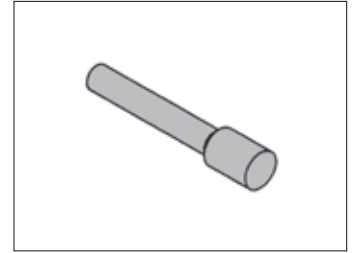

**DIN rail mounting bracket [-D]**

**VVQ2000-57A**  
{For F/L/M/P/S (EX500) kit}

**VVQ2000-57A-S**  
{For S (EX250) kit}

**VVQ2000-57A-T** (For T kit)

**Port plug**  
VVQ1000-58A

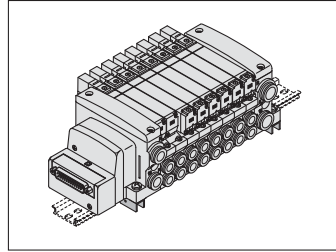
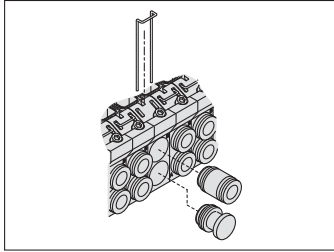

**Direct EXH outlet with built-in silencer [-S]**

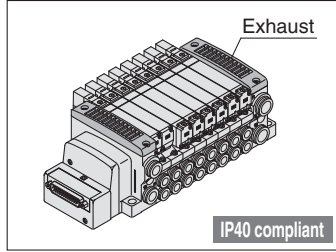

**Silencer (For EXH port)**  
AN20-C10

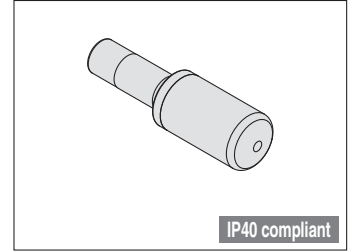

**Elbow fitting assembly**  
VVQ2000-F-L-□

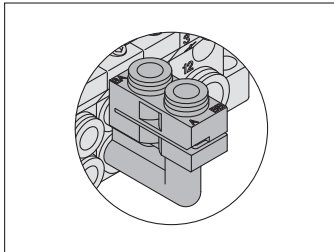

**Dual flow fitting assembly**  
VVQ2000-52A-C10  
N11

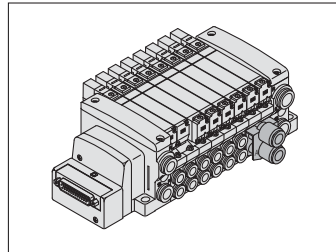

**Double check block**  
VVQ2000-FPG-□□-□

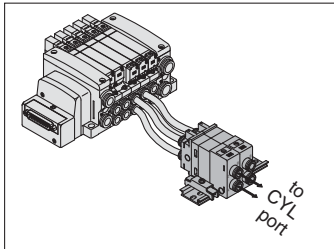

**Special electrical wiring specifications [-K]**

Wiring example)  
D-sub connector

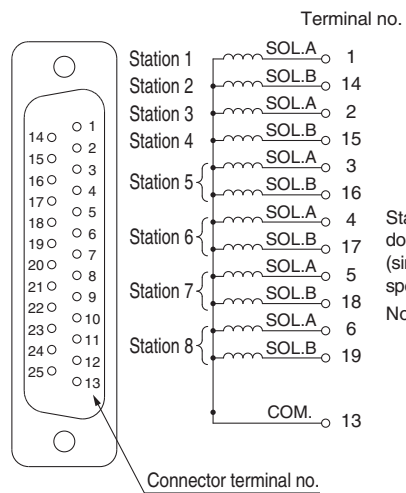

Standard manifolds are for double wiring, but mixed wiring (single and double wiring) can be specified as an option.

Note) Refer to the pages of each kit for details.

F kit ..... P. 33

P kit ..... P. 35

T kit ..... P. 37

L kit ..... P. 39

M kit ..... P. 41



# Plug-in Unit

## Model

### Symbol

2-position single

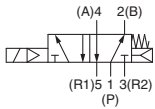

2-position double (Metal)

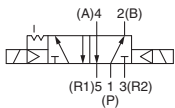

2-position double (Rubber)

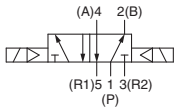

3-position closed centre

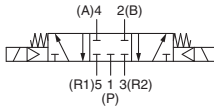

3-position exhaust centre

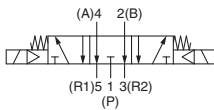

3-position pressure centre

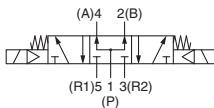

4-position dual 3-port valve (A)

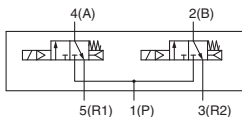

4-position dual 3-port valve (B)

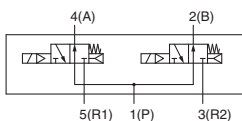

4-position dual 3-port valve (C)

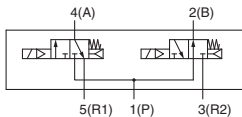

Series	Type of actuation	Model	Flow-rate characteristics										Response time <sup>Note 2)</sup> (ms)		Weight (g)
			1 → 4, 2 (P → A, B)					4, 2 → 5, 3 (A, B → R1, R2)					Standard: 0.4 W	High-speed response: 0.95 W	
			C [dm <sup>3</sup> /(s·bar)]	b	Cv	Q [l/min] (ANR) <sup>Note 3)</sup>	C [dm <sup>3</sup> /(s·bar)]	b	Cv	Q [l/min] (ANR) <sup>Note 3)</sup>					
VQC1000	2-position	Single	Metal seal	VQC1100	0.70	0.15	0.16	163	0.72	0.25	0.18	178	15 or less	12 or less	67
			Rubber seal	VQC1101	0.85	0.20	0.21	204	1.0	0.30	0.25	254	20 or less	15 or less	
	2-position	Double	Metal seal	VQC1200	0.70	0.15	0.16	163	0.72	0.25	0.18	178	13 or less	10 or less	77
			Rubber seal	VQC1201	0.85	0.20	0.21	204	1.0	0.30	0.25	254	20 or less	15 or less	
	3-position	Closed centre	Metal seal	VQC1300	0.68	0.15	0.16	158	0.72	0.25	0.18	178	26 or less	20 or less	77
			Rubber seal	VQC1301	0.70	0.20	0.16	168	0.65	0.42	0.18	179	33 or less	25 or less	
	3-position	Exhaust centre	Metal seal	VQC1400	0.68	0.15	0.16	158	0.72	0.25	0.18	178	26 or less	20 or less	77
			Rubber seal	VQC1401	0.70	0.20	0.16	168	1.0	0.30	0.25	254	33 or less	25 or less	
	3-position	Pressure centre	Metal seal	VQC1500	0.70	0.15	0.16	163	0.72	0.25	0.18	178	26 or less	20 or less	77
			Rubber seal	VQC1501	0.85	0.20	0.21	204	0.65	0.42	0.18	179	33 or less	25 or less	
4-position	Dual 3-port valve	Rubber seal	VQC2 <sup>A</sup> <sub>B</sub> 01	0.70	0.20	0.16	168	0.70	0.20	0.16	168	33 or less	25 or less	77	
VQC2000	2-position	Single	Metal seal	VQC2100	2.0	0.15	0.46	466	2.6	0.15	0.60	606	29 or less	22 or less	95
			Rubber seal	VQC2101	2.2	0.28	0.55	552	3.2	0.30	0.80	814	31 or less	24 or less	
	2-position	Double	Metal seal	VQC2200	2.0	0.15	0.46	466	2.6	0.15	0.60	606	20 or less	15 or less	95
			Rubber seal	VQC2201	2.2	0.28	0.55	552	3.2	0.30	0.80	814	26 or less	20 or less	
	3-position	Closed centre	Metal seal	VQC2300	2.0	0.15	0.46	466	2.0	0.18	0.46	474	38 or less	29 or less	105
			Rubber seal	VQC2301	2.0	0.28	0.49	502	2.2	0.31	0.60	563	44 or less	34 or less	
	3-position	Exhaust centre	Metal seal	VQC2400	2.0	0.15	0.46	466	2.6	0.15	0.60	606	38 or less	29 or less	105
			Rubber seal	VQC2401	2.0	0.28	0.49	502	3.2	0.30	0.80	814	44 or less	34 or less	
	3-position	Pressure centre	Metal seal	VQC2500	2.4	0.17	0.57	565	2.0	0.18	0.46	474	38 or less	29 or less	105
			Rubber seal	VQC2501	3.2	0.28	0.80	804	2.2	0.31	0.60	563	44 or less	34 or less	
4-position	Dual 3-port valve	Rubber seal	VQC2 <sup>A</sup> <sub>B</sub> 01	1.8	0.28	0.46	452	1.8	0.28	0.46	452	44 or less	34 or less	105	

Note 1) Values represented in this column are in the following conditions:

VQC1000: Cylinder port size C6 without a back pressure check valve

VQC2000: Cylinder port size C8 without a back pressure check valve

Note 2) Values represented in this column are based on JIS B 8375-1981 (operating with clean air and a supply pressure of 0.5 MPa. Equipped with light/surge voltage suppressor. Values vary depending on the pressure as well as the air quality.) Values for double type are when the switch is turned ON.

Note 3) These values have been calculated according to ISO6358 and indicate the flow rate under standard conditions with an inlet pressure of 0.6 MPa (relative pressure) and a pressure drop of 0.1 MPa.





## Standard Specifications

Valve specifications	Valve type		Metal seal	Rubber seal
	Fluid		Air	
	Maximum operating pressure		0.7 MPa (High-pressure type: 1.0 MPa)	0.7 MPa
	Minimum operating pressure	Single	0.1 MPa	0.15 MPa
		Double	0.1 MPa	
		3-position	0.1 MPa	0.2 MPa
		4-position	—	0.15 MPa
	Ambient and fluid temperature		-10 to 50°C <sup>Note 1)</sup>	
	Lubrication		Not required	
	Manual override		Push type, Locking type (Tool required) semi-standard	
Impact/Vibration resistance		150/30 m/s <sup>2</sup> <sup>Note 2)</sup>		
Enclosure		Dustproof (IP67 compatible) <sup>Note 3)</sup>		
Electrical specifications	Rated coil voltage		24 VDC	
	Allowable voltage fluctuation		±10% of rated voltage	
	Coil insulation type		Equivalent to Class B	
	Power consumption (Current)	24 VDC	0.4 W DC (17 mA), 0.95 W DC (40 mA) <sup>Note 4)</sup>	
		12 VDC	0.4 W DC (34 mA), 0.95 W DC (80 mA) <sup>Note 4)</sup>	

Note 1) Use dry air to prevent condensation when operating at low temperatures.

Note 2) Impact resistance ..... No malfunction resulted from the impact test using a drop impact tester. Test was performed one time each in the axial and right angle directions of the main valve and armature for both energized and de-energized states.

Vibration resistance ... No malfunction occurred in a one-sweep test between 45 and 2000 Hz. Test was performed in the axial and right angle directions of the main valve and armature for both energized and de-energized states.

Note 3) Refer to page 1 and 2 for applicable variations.

Note 4) Value for high-speed response, high-pressure type (0.95 W)

## Manifold Specifications

Series	Base model	Connection type	Piping specifications			Applicable stations <sup>Note 2)</sup>	Applicable solenoid valves	5-station weight (g)
			Port direction	Port size <sup>Note 1)</sup>				
				1, 3 (P, R)	2, 4 (A, B)			
VQC1000	VV5QC11-□□□□	<b>F kit: D-sub connector</b> <b>P kit: Flat ribbon cable</b> <b>T kit: Terminal block box</b> <b>S kit: Serial transmission</b> <b>L kit: Lead wire</b> <b>M kit: Circular connector</b>	Side	C8 (ø8) Option: Direct EXH outlet with built-in silencer	C3 (ø3.2) C4 (ø4) C6 (ø6) M5 (M5 thread)	( F/L/M/P kit ) ( 1 to 12 stations ) ( T kit ) ( 1 to 10 stations )	VQC1□00-5 VQC1□01-5	643 (Single) 754 (Double, 3-position)
VQC2000	VV5QC21-□□□□		Side	C10 (ø10) Option: Direct EXH outlet with built-in silencer Branch type C12 (ø12)	C4 (ø4) C6 (ø6) C8 (ø8)	( S kit ) ( 1 to 8 stations: EX500 ) ( 1 to 12 stations: EX250 )	VQC2□00-5 VQC2□01-5	1076 (Single) 1119 (Double, 3-position)

Note 1) Inch-size one-touch fittings are also available.

Note 2) Special wiring specifications are available as semi-standard to increase the maximum number of stations.

# Series VQC

## S Series VQC1000

Kit (Serial transmission) For EX500 Gateway Decentralised System 2 (128 points) IP67 compliant

### VV5QC11 S kit (Serial transmission kit: EX500)

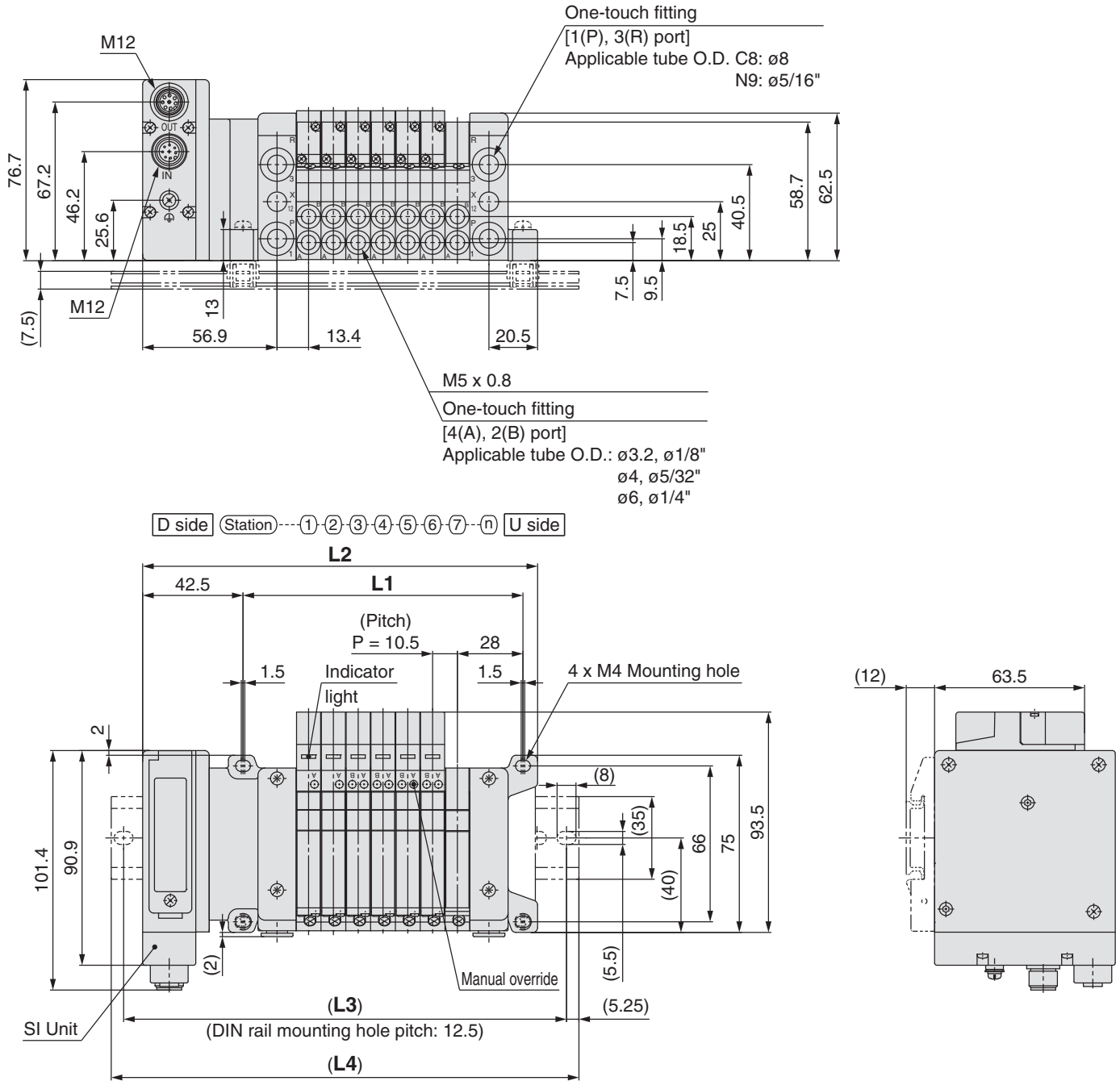

#### L: Dimensions

n: Stations

L \ n	1	2	3	4	5	6	7	8	9	10	11	12	13	14	15
L1	55.5	66	76.5	87	97.5	108	118.5	129	139.5	150	160.5	171	181.5	192	202.5
L2	104.2	114.7	125.2	135.7	146.2	156.7	167.2	177.7	188.2	198.7	209.2	219.7	230.2	240.7	251.2
L3	125	137.5	150	162.5	175	187.5	187.5	200	212.5	225	237.5	250	250	262.5	275
L4	135.5	148	160.5	173	185.5	198	198	210.5	223	235.5	248	260.5	260.5	273	285.5

L \ n	16	17	18	19	20	21	22	23	24
L1	213	223.5	234	244.5	255	265.5	276	286.5	297
L2	261.7	272.2	282.7	293.2	303.7	314.2	324.7	335.2	345.7
L3	287.5	300	312.5	325	325	337.5	350	362.5	375
L4	298	310.5	323	335.5	335.5	348	360.5	373	385.5

# S Series VQC2000

Kit (Serial transmission) For EX500 Gateway Decentralised System 2 (128 points) IP67 compliant

## VV5QC21 S kit (Serial transmission kit: EX500)

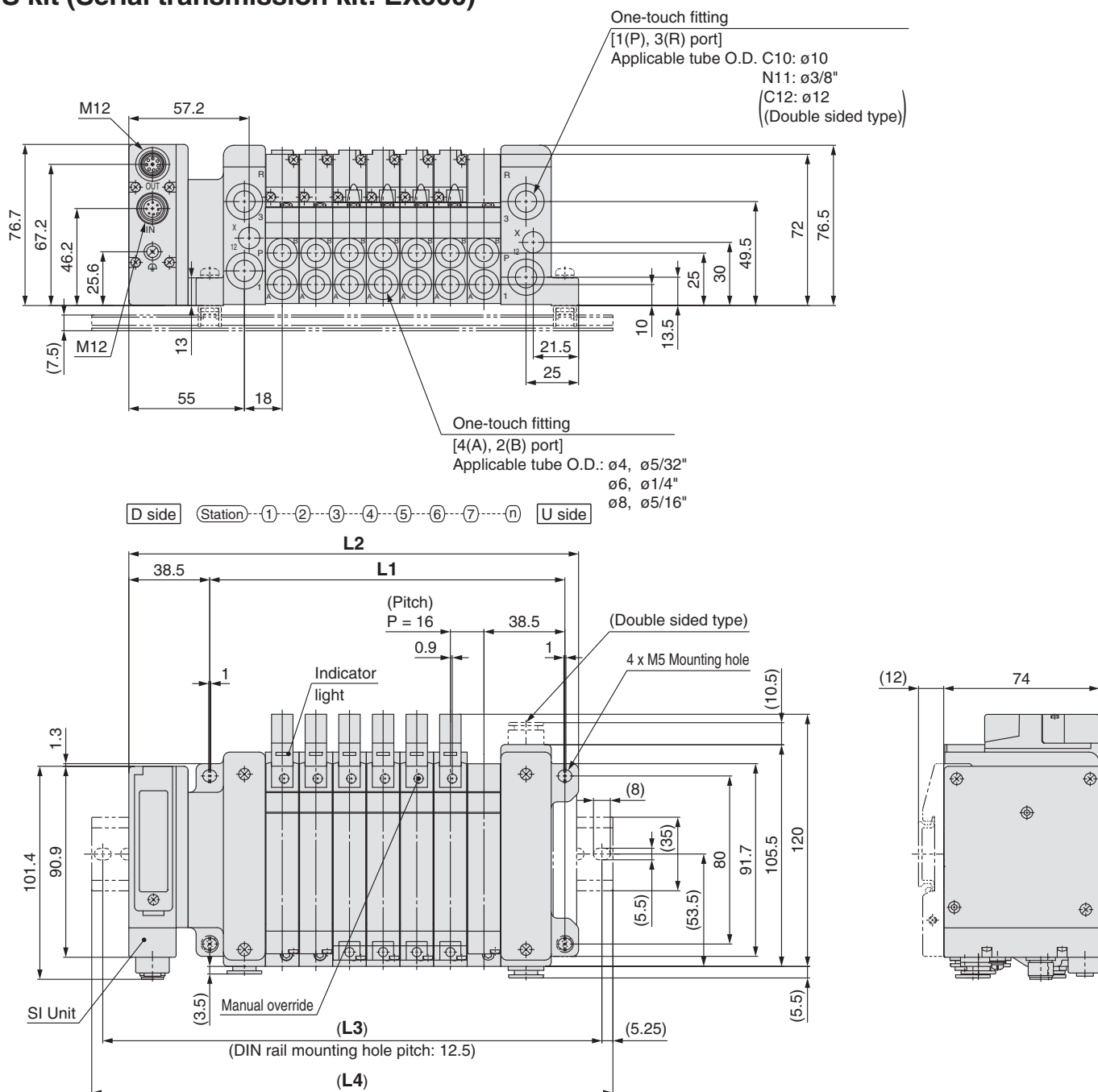

### L: Dimensions

n: Stations

L \ n	1	2	3	4	5	6	7	8	9	10	11	12	13	14	15
L1	73	89	105	121	137	153	169	185	201	217	233	249	265	281	297
L2	118	134	150	166	182	198	214	230	246	262	278	294	310	326	342
L3	137.5	162.5	175	187.5	212.5	225	237.5	250	275	287.5	300	325	337.5	350	362.5
L4	148	173	185.5	198	223	235.5	248	260.5	285.5	298	310.5	335.5	348	360.5	373

L \ n	16	17	18	19	20	21	22	23	24
L1	313	329	345	361	377	393	409	425	441
L2	358	374	390	406	422	438	454	470	486
L3	387.5	400	412.5	437.5	450	462.5	475	500	512.5
L4	398	410.5	423	448	460.5	473	485.5	510.5	523

# Series VQC

## S Series VQC1000

kit (Serial transmission) For EX500 Gateway Decentralised System (64 points) IP67 compliant

### VV5QC11 S kit (Serial transmission kit: EX500)

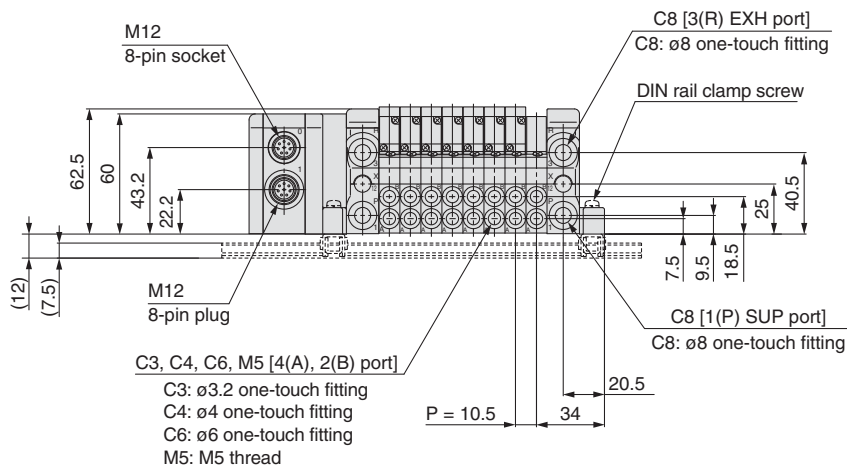

D side Stations 1 2 3 4 5 6 7 8 n U side

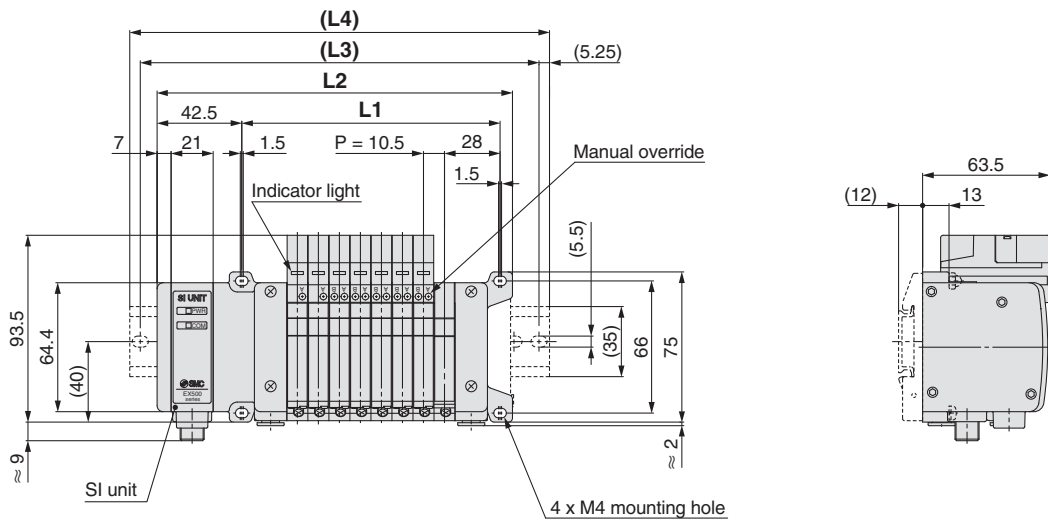

The dashed lines indicate DIN rail mounting [-D] (with DIN rail mounting bracket).

Formula:  $L1 = 10.5n + 45$ ,  $L2 = 10.5n + 93.5$  n: Stations (Maximum 16 stations)

n	1	2	3	4	5	6	7	8	9	10	11	12	13	14	15	16
L1	55.5	66	76.5	87	97.5	108	118.5	129	139.5	150	160.5	171	181.5	192	202.5	213
L2	104	114.5	125	135.5	146	156.5	167	177.5	188	198.5	209	219.5	230	240.5	251	261.5
L3	125	137.5	150	162.5	175	187.5	187.5	200	212.5	225	237.5	250	250	262.5	275	287.5
L4	135.5	148	160.5	173	185.5	198	198	210.5	223	235.5	248	260.5	260.5	273	285.5	298



# S Series VQC2000

kit (Serial transmission) For EX500 Gateway Decentralised System (64 points) IP67 compliant

## VV5QC21

S kit (Serial transmission kit: EX500)

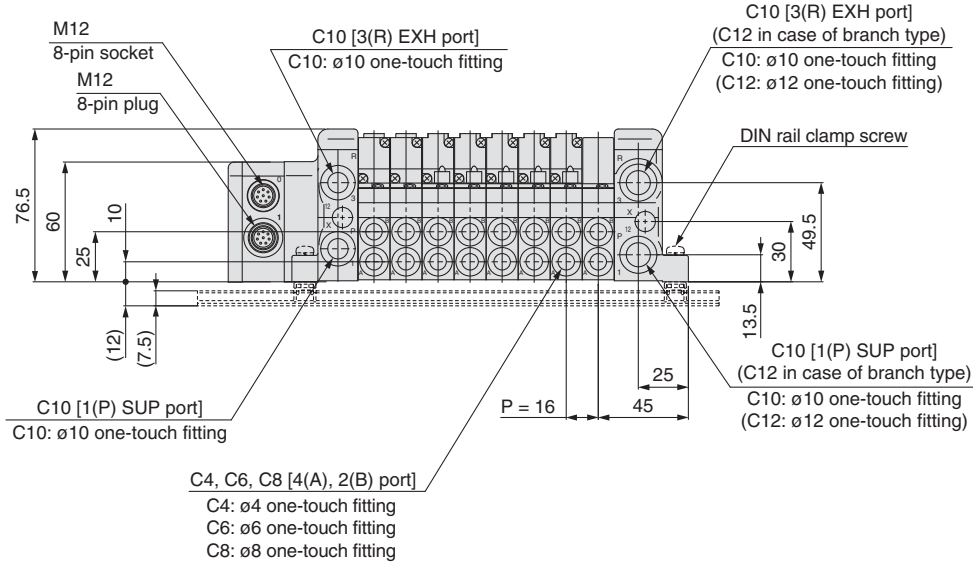

D side Stations 1 2 3 4 5 6 7 8 n U side

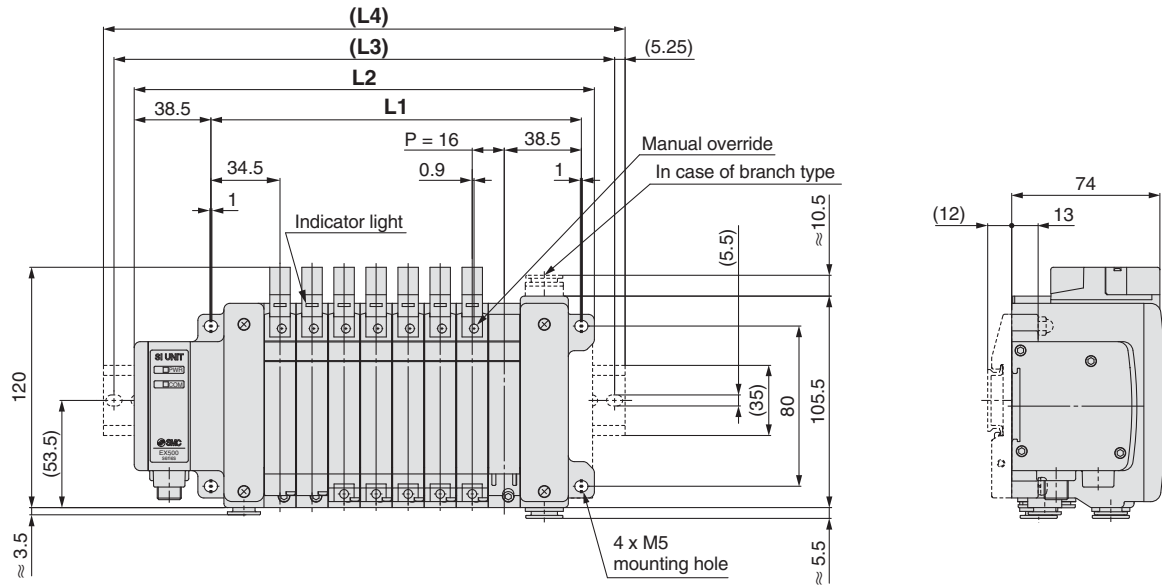

The dashed lines indicate DIN rail mounting [-D] (with DIN rail mounting bracket).

Formula:  $L1 = 16n + 57$ ,  $L2 = 16n + 102$  n: Stations (Maximum 16 stations)

L \ n	1	2	3	4	5	6	7	8	9	10	11	12	13	14	15	16
<b>L1</b>	73	89	105	121	137	153	169	185	201	217	233	249	265	281	297	313
<b>L2</b>	118	134	150	166	182	198	214	230	246	262	278	294	310	326	342	358
<b>L3</b>	162.5	150	175	187.5	212.5	225	237.5	250	275	287.5	300	325	337.5	350	362.5	387.5
<b>L4</b>	173	160.5	185.5	198	223	235.5	248	260.5	285.5	298	310.5	335.5	348	360.5	373	398

# Series VQC

## S Series VQC1000

kit (Serial transmission) For EX600 Integrated-type (I/O) serial transmission system **IP67 compliant**

### VV5QC11

#### S kit (Serial transmission kit: EX600)

Power supply with M12 connector

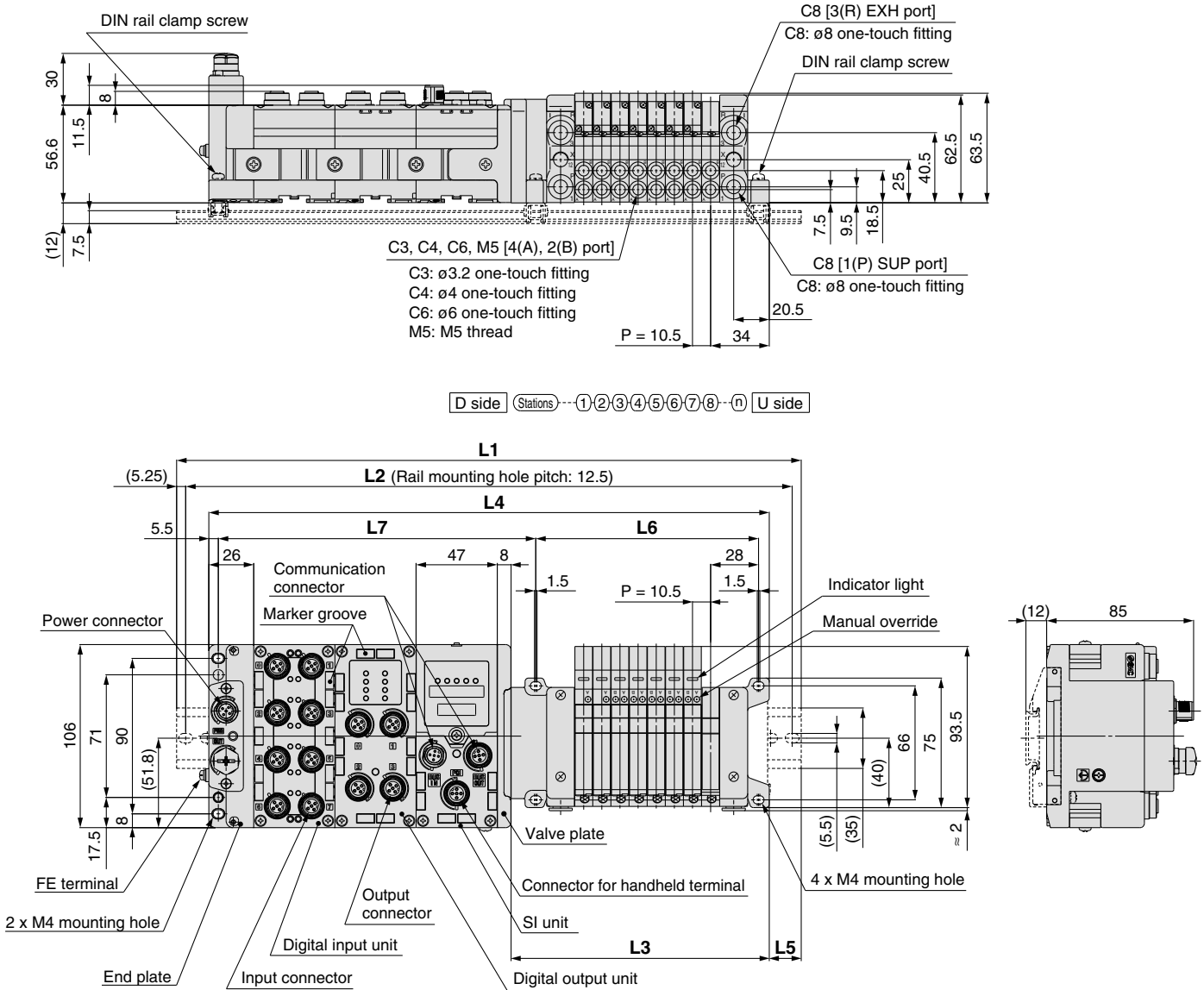

$L2 = L1 - 10.5$   
 $L3 = 10.5 \times n1 + 65.5$   
 $L4 = L3 + 81 + 47 \times n2$   
 $L5 = (L1 - L4) / 2$   
 $L6 = 10.5 \times n1 + 45$   
 $L7 = 47 \times n2 + 89.8$

#### L1: DIN Rail Full Length

I/O unit stations (n2) \ Valve stations (n1)	1	2	3	4	5	6	7	8	9	10	11	12	13	14	15	16	17	18	19	20	21	22	23	24
0	198	198	210.5	223	235.5	248	260.5	260.5	273	285.5	298	310.5	323	335.5	335.5	348	360.5	373	385.5	398	398	410.5	423	435.5
1	235.5	248	260.5	273	285.5	298	298	310.5	323	335.5	348	360.5	360.5	373	385.5	398	410.5	423	423	435.5	448	460.5	473	485.5
2	285.5	298	310.5	323	323	335.5	348	360.5	373	385.5	398	398	410.5	423	435.5	448	460.5	460.5	473	485.5	498	510.5	523	523
3	335.5	348	360.5	360.5	373	385.5	398	410.5	423	423	435.5	448	460.5	473	485.5	485.5	498	510.5	523	535.5	548	560.5	560.5	573
4	385.5	385.5	398	410.5	423	435.5	448	460.5	460.5	473	485.5	498	510.5	523	523	535.5	548	560.5	573	585.5	585.5	598	610.5	623
5	423	435.5	448	460.5	473	485.5	485.5	498	510.5	523	535.5	548	548	560.5	573	585.5	598	610.5	623	623	635.5	648	660.5	673
6	473	485.5	498	510.5	523	523	535.5	548	560.5	573	585.5	585.5	598	610.5	623	635.5	648	648	660.5	673	685.5	698	710.5	710.5
7	523	535.5	548	548	560.5	573	585.5	598	610.5	610.5	623	635.5	648	660.5	673	685.5	685.5	698	710.5	723	735.5	748	748	760.5
8	573	585.5	585.5	598	610.5	623	635.5	648	648	660.5	673	685.5	698	710.5	710.5	723	735.5	748	760.5	773	773	785.5	798	810.5
9	610.5	623	635.5	648	660.5	673	673	685.5	698	710.5	723	735.5	748	748	760.5	773	785.5	798	810.5	810.5	823	835.5	848	860.5

# S Series VQC1000

kit (Serial transmission) For EX600 Integrated-type (I/O) serial transmission system **IP67 compliant**

**VV5QC11**  
**S kit (Serial transmission kit: EX600)**  
 Power supply with 7/8 inch connector

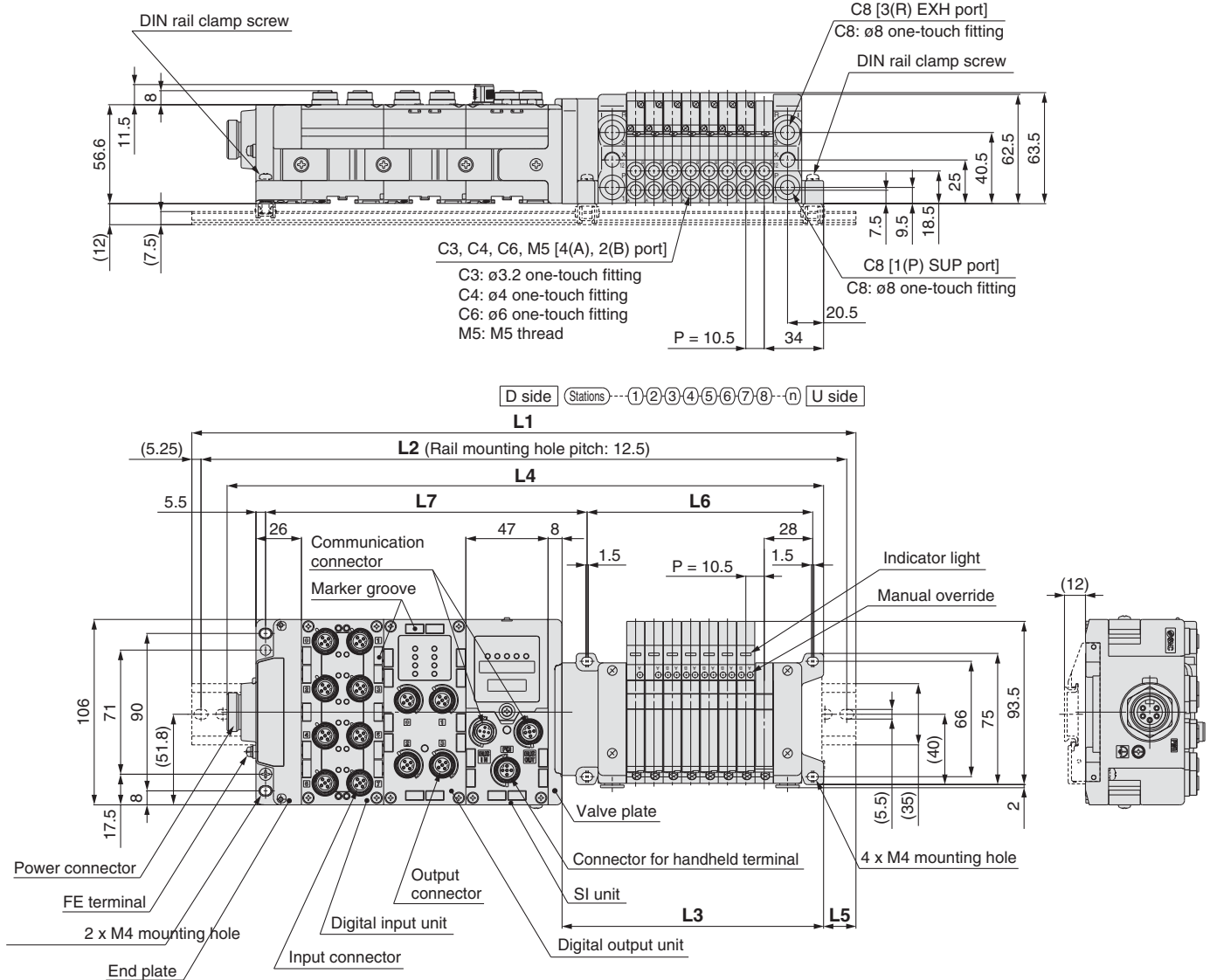

$L2 = L1 - 10.5$   
 $L3 = 10.5 \times n1 + 65.5$   
 $L4 = L3 + 97.5 + 47 \times n2$   
 $L5 = (L1 - L4) / 2$   
 $L6 = 10.5 \times n1 + 45$   
 $L7 = 47 \times n2 + 89.8$

**L1: DIN Rail Full Length**

I/O unit stations (n2)	Valve stations (n1)																							
	1	2	3	4	5	6	7	8	9	10	11	12	13	14	15	16	17	18	19	20	21	22	23	24
0	210.5	223	235.5	235.5	248	260.5	273	285.5	298	298	310.5	323	335.5	348	360.5	373	373	385.5	398	410.5	423	435.5	435.5	448
1	260.5	273	273	285.5	298	310.5	323	335.5	335.5	348	360.5	373	385.5	398	398	410.5	423	435.5	448	460.5	460.5	473	485.5	498
2	298	310.5	323	335.5	348	360.5	360.5	373	385.5	398	410.5	423	435.5	435.5	448	460.5	473	485.5	498	498	510.5	523	535.5	548
3	348	360.5	373	385.5	398	398	410.5	423	435.5	448	460.5	460.5	473	485.5	498	510.5	523	523	535.5	548	560.5	573	585.5	598
4	398	410.5	423	423	435.5	448	460.5	473	485.5	498	498	510.5	523	535.5	548	560.5	560.5	573	585.5	598	610.5	623	623	635.5
5	448	460.5	460.5	473	485.5	498	510.5	523	523	535.5	548	560.5	573	585.5	585.5	598	610.5	623	635.5	648	660.5	660.5	673	685.5
6	485.5	498	510.5	523	535.5	548	560.5	560.5	573	585.5	598	610.5	623	623	635.5	648	660.5	673	685.5	685.5	698	710.5	723	735.5
7	535.5	548	560.5	573	585.5	585.5	598	610.5	623	635.5	648	648	660.5	673	685.5	698	710.5	723	723	735.5	748	760.5	773	785.5
8	585.5	598	610.5	623	623	635.5	648	660.5	673	685.5	685.5	698	710.5	723	735.5	748	748	760.5	773	785.5	798	810.5	810.5	823
9	635.5	648	648	660.5	673	685.5	698	710.5	710.5	723	735.5	748	760.5	773	785.5	785.5	798	810.5	823	835.5	848	848	860.5	873

# Series VQC

## S Series VQC2000

kit (Serial transmission) For EX600 Integrated-type (I/O) serial transmission system **IP67 compliant**

### VV5QC21

### S kit (Serial transmission kit: EX600)

### Power supply with M12 connector

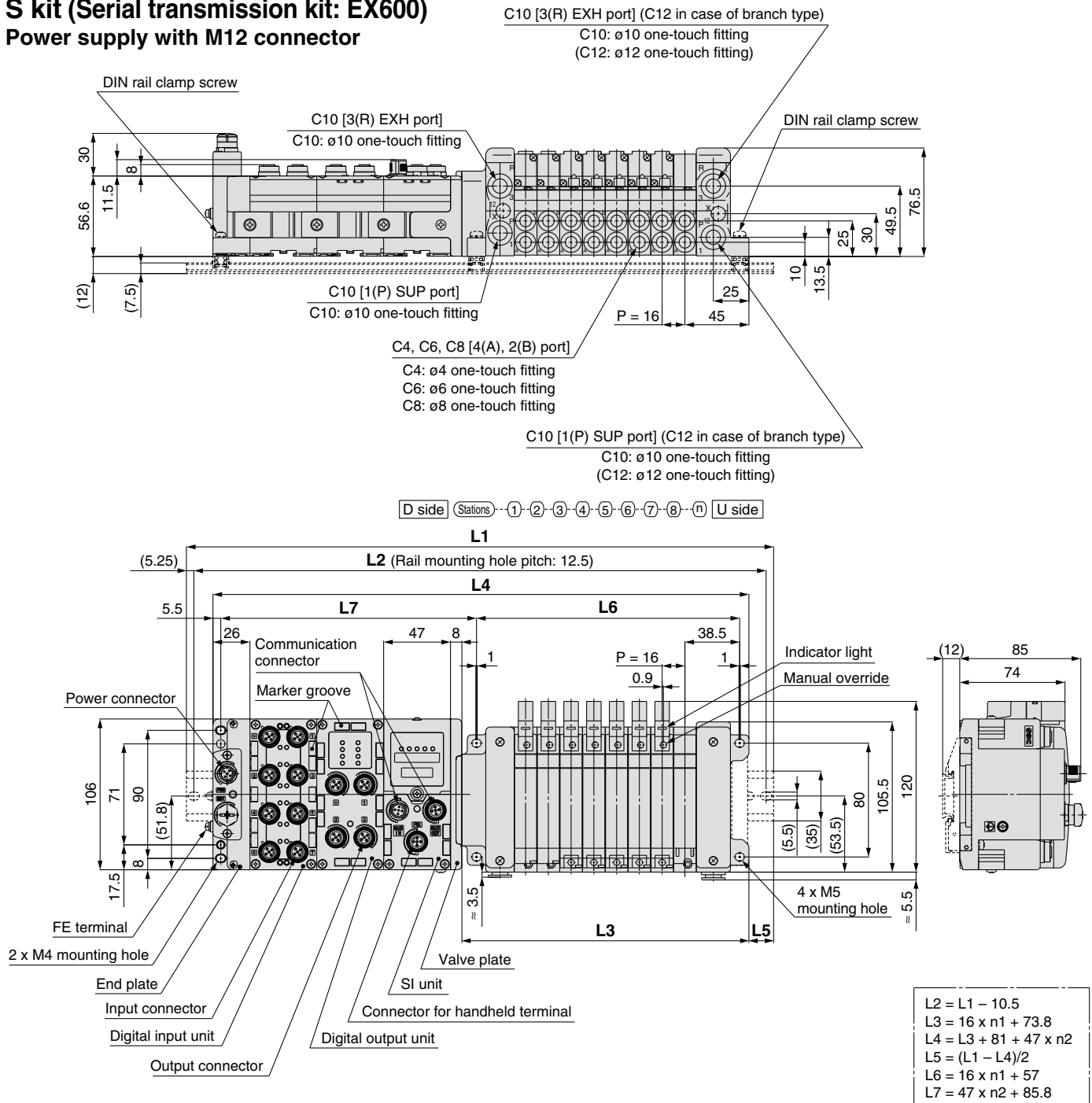

### L1: DIN Rail Full Length

I/O unit stations (n2) \ Valve stations (n1)	1	2	3	4	5	6	7	8	9	10	11	12	13	14	15	16	17	18	19	20	21	22	23	24
0	210.5	223	235.5	260.5	273	285.5	298	323	335.5	348	373	385.5	398	410.5	435.5	448	460.5	473	498	510.5	523	548	560.5	573
1	248	273	285.5	298	323	335.5	348	360.5	385.5	398	410.5	435.5	448	460.5	473	498	510.5	523	548	560.5	573	585.5	610.5	623
2	298	323	335.5	348	360.5	385.5	398	410.5	423	448	460.5	473	498	510.5	523	535.5	560.5	573	585.5	610.5	623	635.5	648	673
3	348	360.5	385.5	398	410.5	423	448	460.5	473	498	510.5	523	535.5	560.5	573	585.5	598	623	635.5	648	673	685.5	698	710.5
4	398	410.5	423	448	460.5	473	485.5	510.5	523	535.5	560.5	573	585.5	598	623	635.5	648	673	685.5	698	710.5	735.5	748	760.5
5	448	460.5	473	485.5	510.5	523	535.5	548	573	585.5	598	623	635.5	648	660.5	685.5	698	710.5	735.5	748	760.5	773	798	810.5
6	485.5	510.5	523	535.5	548	573	585.5	598	623	635.5	648	660.5	685.5	698	710.5	723	748	760.5	773	798	810.5	823	835.5	860.5
7	535.5	548	573	585.5	598	610.5	635.5	648	660.5	685.5	698	710.5	723	748	760.5	773	798	810.5	823	835.5	860.5	873	885.5	898
8	585.5	598	610.5	635.5	648	660.5	673	698	710.5	723	748	760.5	773	785.5	810.5	823	835.5	860.5	873	885.5	898	923	935.5	948
9	635.5	648	660.5	673	698	710.5	723	748	760.5	773	785.5	810.5	823	835.5	848	873	885.5	898	923	935.5	948	960.5	985.5	998.5



# S Series VQC2000

kit (Serial transmission) For EX600 Integrated-type (I/O) serial transmission system **IP67 compliant**

## VV5QC21 S kit (Serial transmission kit: EX600) Power supply with 7/8 inch connector

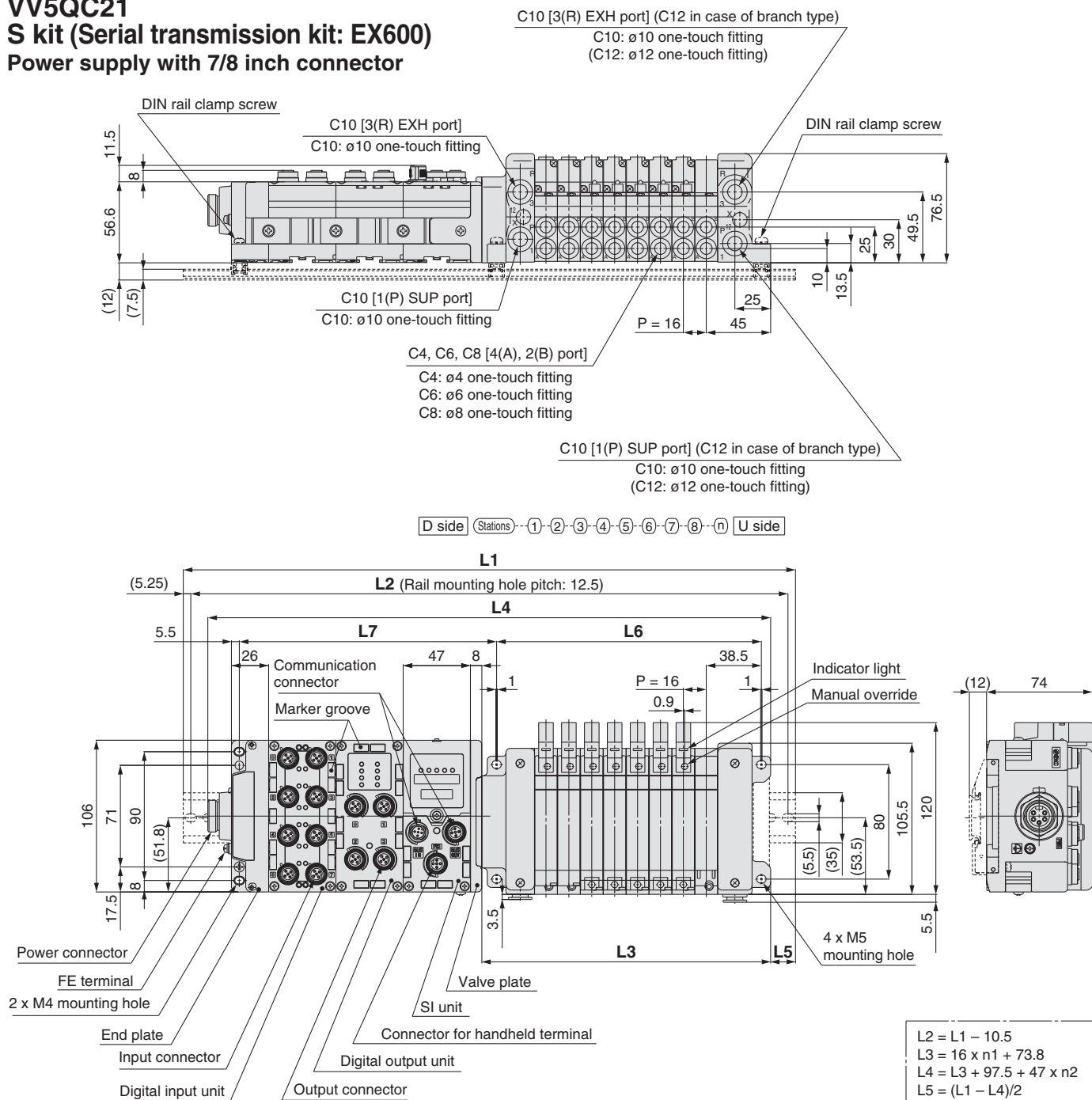

### L1: DIN Rail Full Length

I/O unit stations (n2) \ Valve stations (n1)	1	2	3	4	5	6	7	8	9	10	11	12	13	14	15	16	17	18	19	20	21	22	23	24	
0	223	235.5	260.5	273	285.5	298	323	335.5	348	373	385.5	398	410.5	435.5	448	460.5	485.5	498	510.5	523	548	560.5	573	585.5	585.5
1	273	285.5	298	323	335.5	348	360.5	385.5	398	410.5	435.5	448	460.5	473	498	510.5	523	548	560.5	573	585.5	610.5	623	635.5	635.5
2	323	335.5	348	360.5	385.5	398	410.5	435.5	448	460.5	473	498	510.5	523	535.5	560.5	573	585.5	610.5	623	635.5	648	673	685.5	685.5
3	360.5	385.5	398	410.5	423	448	460.5	473	498	510.5	523	535.5	560.5	573	585.5	610.5	623	635.5	648	673	685.5	698	710.5	735.5	735.5
4	410.5	423	448	460.5	473	485.5	510.5	523	535.5	560.5	573	585.5	598	623	635.5	648	673	685.5	698	710.5	735.5	748	760.5	785.5	785.5
5	460.5	473	485.5	510.5	523	535.5	560.5	573	585.5	598	623	635.5	648	660.5	685.5	698	710.5	735.5	748	760.5	773	798	810.5	823	823
6	510.5	523	535.5	548	573	585.5	598	623	635.5	648	660.5	685.5	698	710.5	735.5	748	760.5	773	798	810.5	823	835.5	860.5	873	873
7	548	573	585.5	598	610.5	635.5	648	660.5	685.5	698	710.5	723	748	760.5	773	798	810.5	823	835.5	860.5	873	885.5	910.5	923	923
8	598	610.5	635.5	648	660.5	685.5	698	710.5	723	748	760.5	773	785.5	810.5	823	835.5	860.5	873	885.5	898	923	935.5	948	973	973
9	648	660.5	673	698	710.5	723	748	760.5	773	785.5	810.5	823	835.5	860.5	873	885.5	898	923	935.5	948	960.5	985.5	985.5	—	—

# Series VQC

## S Series VQC1000/2000

kit (Serial transmission) For EX250 Integrated-type (I/O) serial transmission system **IP67 compliant**

### VV5QC11

### S kit (Serial transmission kit: EX250)

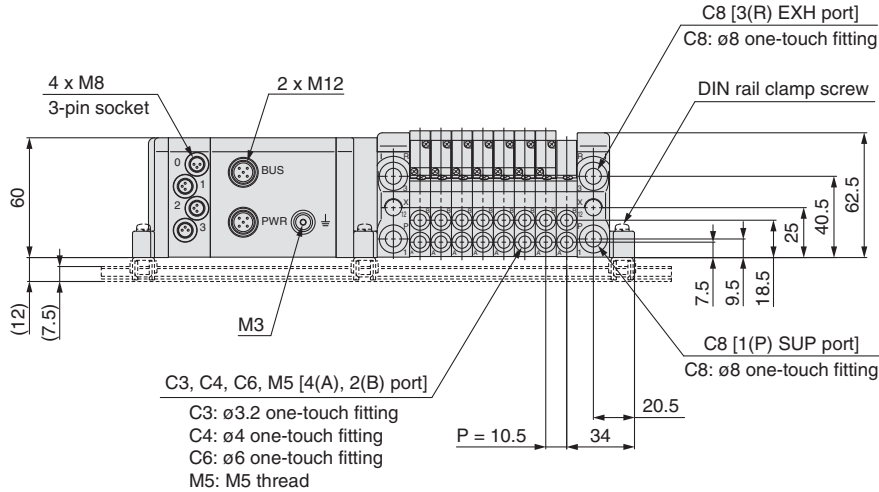

D side Stations 1 2 3 4 5 6 7 8 n U side

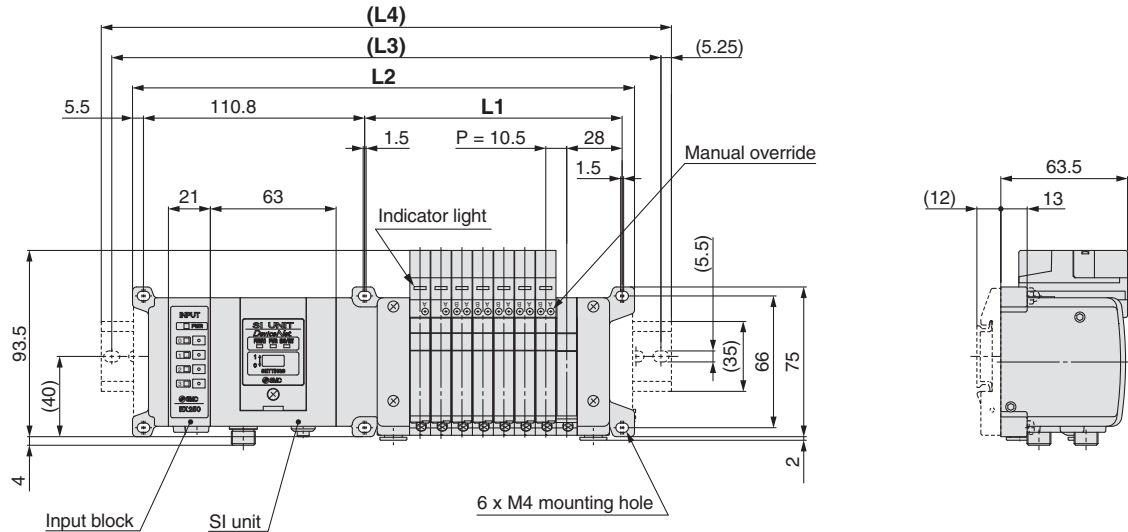

The dashed lines indicate DIN rail mounting [-D] (with DIN rail mounting bracket).

Formula:  $L1 = 10.5n + 45$ ,  $L2 = 10.5n + 167.5$  (For one input block. Add 21 mm for each additional input block.) n: Stations (Maximum 24 stations)

L \ n	1	2	3	4	5	6	7	8	9	10	11	12	13	14	15	16	17	18	19	20	21	22	23	24
L1	55.5	66	76.5	87	97.5	108	118.5	129	139.5	150	160.5	171	181.5	192	202.5	213	223.5	234	244.5	255	265.5	276	286.5	297
L2	178	188.5	199	209.5	220	230.5	241	251.5	262	272.5	283	293.5	304	314.5	325	335.5	346	356.5	367	377.5	388	398.5	409	419.5
L3	200	212.5	225	237.5	250	250	262.5	275	287.5	300	312.5	325	325	337.5	350	362.5	375	387.5	387.5	400	412.5	425	437.5	450
L4	210.5	223	235.5	248	260.5	260.5	273	285.5	298	310.2	323	335.5	335.5	348	360.5	373	385.5	398	398	410.5	423	435.5	448	460.5

# S Series VQC1000

IP40 compliant

Kit (Serial transmission) For EX260 Integrated-type (For Output) Serial Transmission System **IP67 compliant**

## VV5QC11 S kit (Serial transmission kit: EX260)

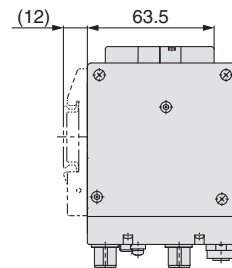
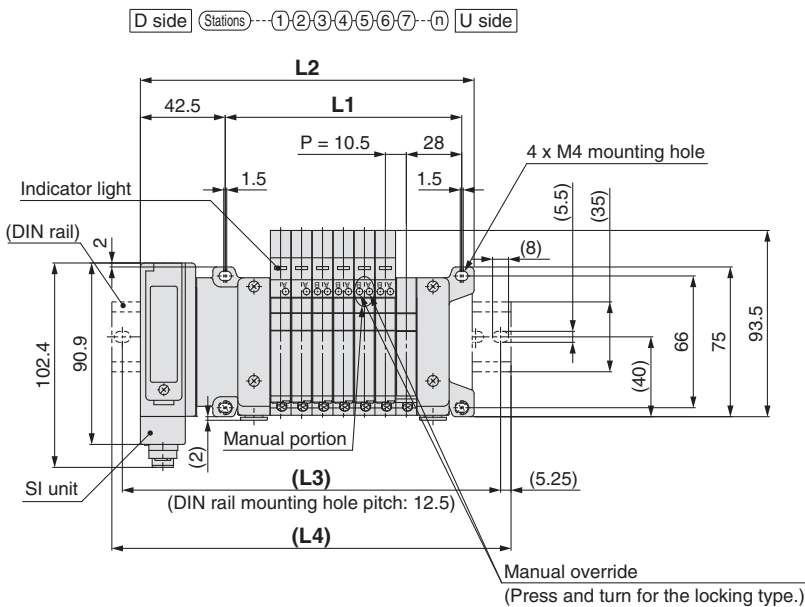
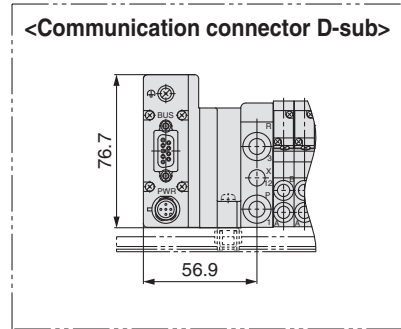
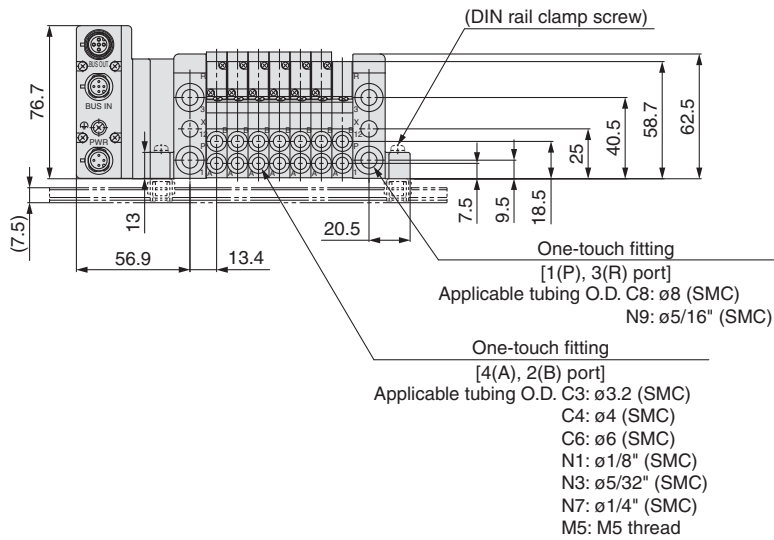

n: Stations (Maximum 24 stations)

L \ n	1	2	3	4	5	6	7	8	9	10	11	12	13	14	15	16	17	18	19	20	21	22	23	24
L1	55.5	66	76.5	87	97.5	108	118.5	129	139.5	150	160.5	171	181.5	192	202.5	213	223.5	234	244.5	255	265.5	276	286.5	297
L2	104.2	114.7	125.2	135.7	146.2	156.7	167.2	177.7	188.2	198.7	209.2	219.7	230.2	240.7	251.2	261.7	272.2	282.7	293.2	303.7	314.2	324.7	335.2	345.7
L3	125	137.5	150	162.5	175	187.5	197.5	200	212.5	225	237.5	250	250	262.5	275	287.5	300	312.5	325	325	337.5	350	362.5	375
L4	135.5	148	160.5	173	185.5	198	198	210.5	223	235.5	248	260.5	260.5	273	285.5	298	310.5	323	335.5	335.5	348	360.5	373	385.5

# Series VQC

## S Series VQC2000

IP40 compliant

Kit (Serial transmission) For EX260 Integrated-type (For Output) Serial Transmission System IP67 compliant

### VV5QC21

### S kit (Serial transmission kit: EX260)

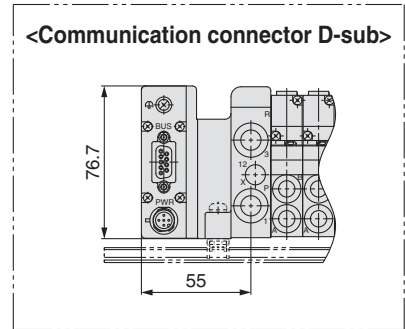
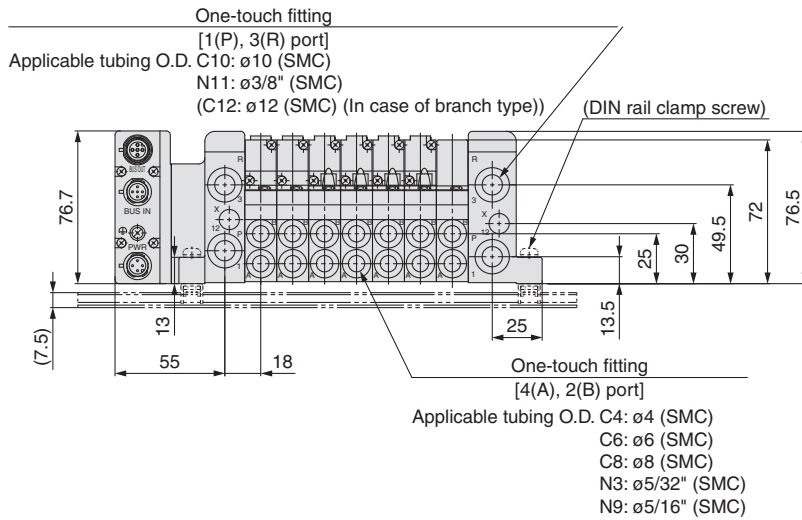

D side Stations ① ② ③ ④ ⑤ ⑥ ⑦ ... ① U side

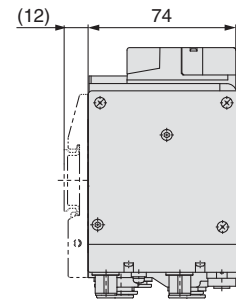
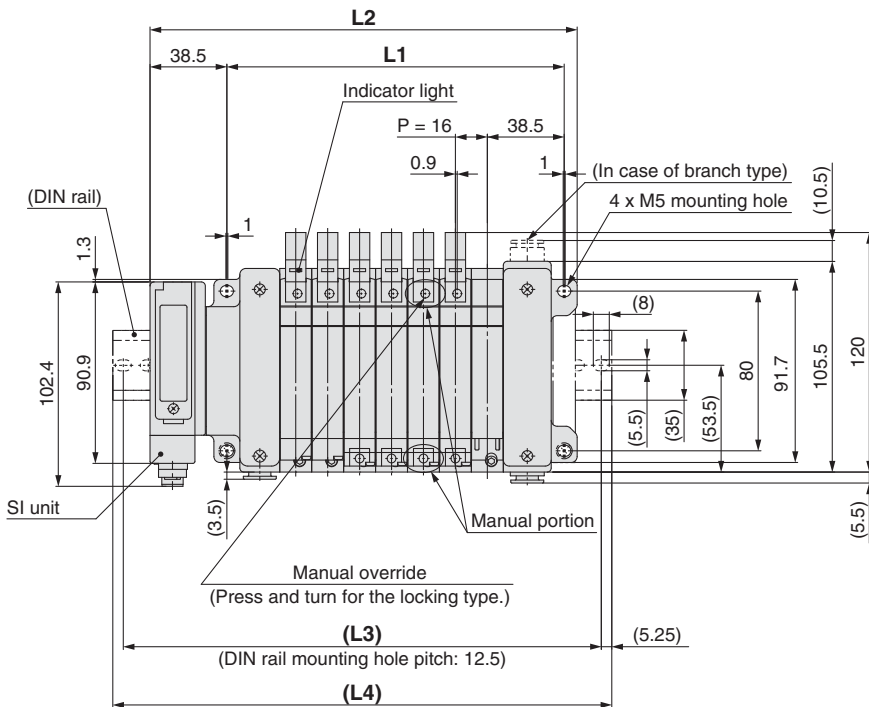

n: Stations (Maximum 24 stations)

L \ n	1	2	3	4	5	6	7	8	9	10	11	12	13	14	15	16	17	18	19	20	21	22	23	24
L1	73	89	105	121	137	153	169	185	201	217	233	249	265	281	297	313	329	345	361	377	393	409	425	441
L2	118	134	150	166	182	198	214	230	246	262	278	294	310	326	342	358	374	390	406	422	438	454	470	486
L3	137.5	162.5	175	187.5	212.5	225	237.5	250	275	287.5	300	325	337.5	350	362.5	387.5	400	412.5	437.5	450	462.5	475	500	512.5
L4	148	173	185.5	198	223	235.5	248	260.5	285.5	298	310.5	335.5	348	360.5	373	398	410.5	423	448	460.5	473	485.5	510.5	523

# S Series VQC1000/2000

kit (Serial transmission) For EX250 Integrated-type (I/O) serial transmission system **IP67 compliant**

## VV5QC21 S kit (Serial transmission kit: EX250)

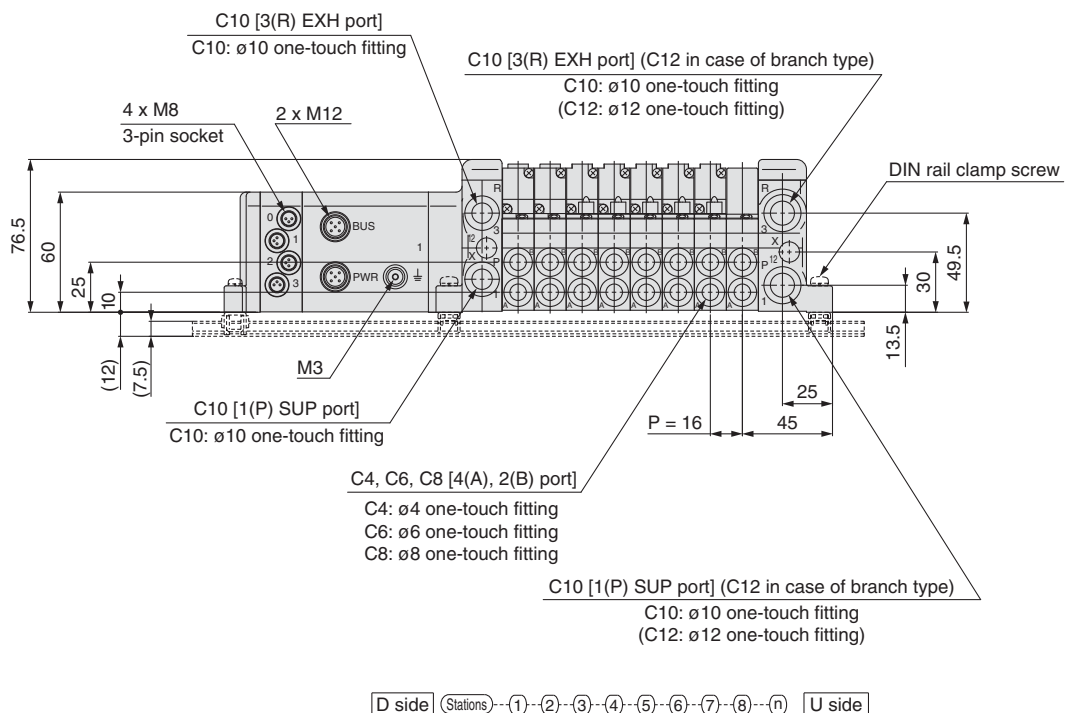

D side Stations 1 2 3 4 5 6 7 8 n U side

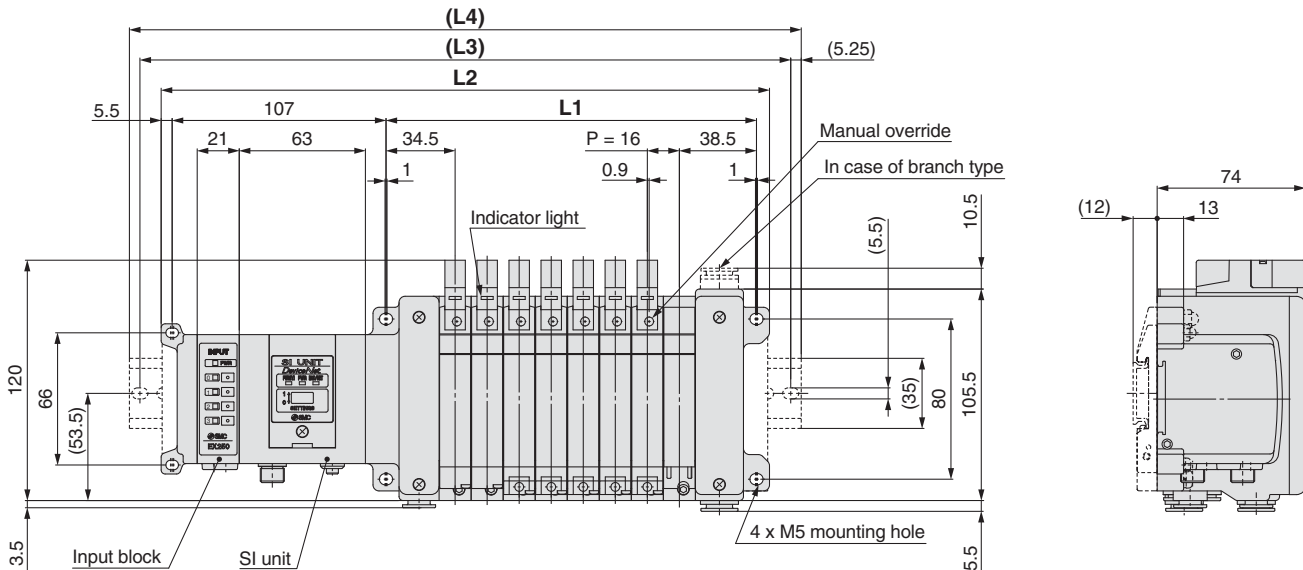

The dashed lines indicate DIN rail mounting [-D] (with DIN rail mounting bracket).

Formula:  $L1 = 16n + 57$ ,  $L2 = 16n + 176$  (For one input block. Add 21 mm for each additional input block.) n: Stations (Maximum 24 stations)

L \ n	1	2	3	4	5	6	7	8	9	10	11	12	13	14	15	16	17	18	19	20	21	22	23	24
<b>L1</b>	73	89	105	121	137	153	169	185	201	217	233	249	265	281	297	313	329	345	361	377	393	409	425	441
<b>L2</b>	192	208	224	240	256	272	288	304	320	336	352	368	384	400	416	432	448	464	480	496	512	528	544	560
<b>L3</b>	212.5	237.5	250	262.5	275	287.5	312.5	325	337.5	362.5	375	387.5	400	425	437.5	450	462.5	487.5	500	512.5	537.5	550	562.5	587.5
<b>L4</b>	223	248	260.5	273	285.5	298	323	335.5	348	373	385.5	398	410.5	435.5	448	460.5	473	498	510.5	523	548	560.5	573	598



# Series VQC

## S Series VQC1000/2000

Kit (Serial transmission) For EX126 Integrated-type (For Output) Serial Transmission System IP67 compliant

### VV5QC11 S kit (Serial transmission kit: EX126)

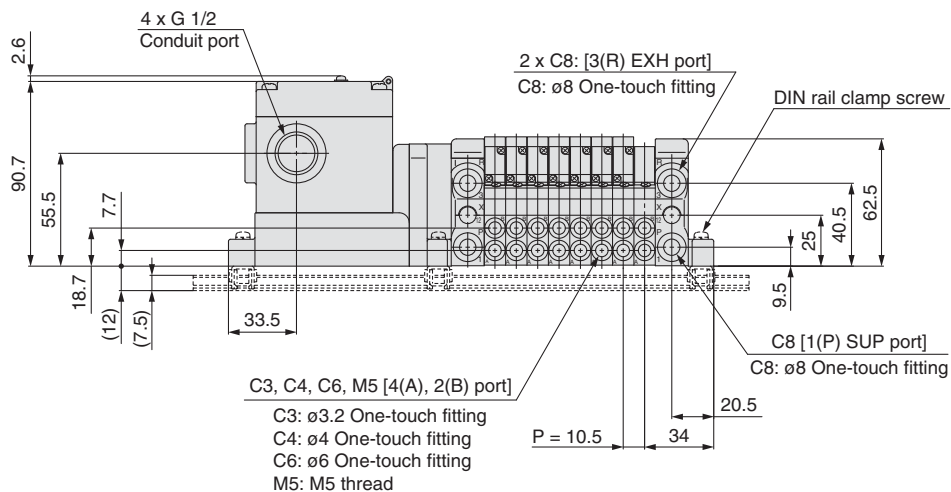

D side (Stations) 1-2-3-4-5-6-7-8-n U side

SI unit

Use a drip proof plug assembly (AXT100-B04A) on the unused conduit port (G1/2).

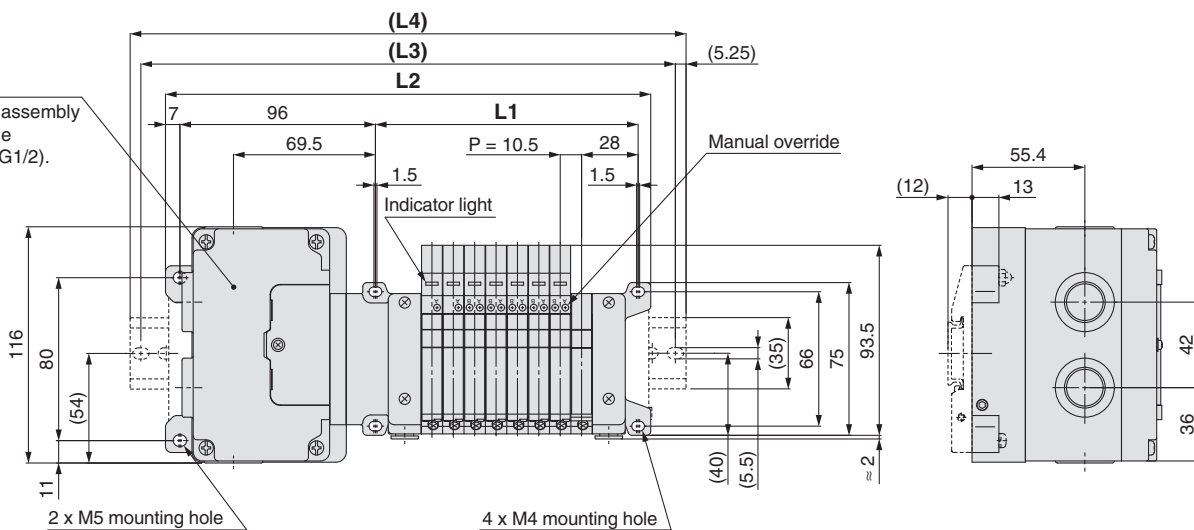

The dashed lines indicate DIN rail mounting [-D] (with DIN rail mounting bracket).

Formula:  $L1 = 10.5n + 45$ ,  $L2 = 10.5n + 154.5$  n: Stations (Maximum 16 stations)

L \ n	1	2	3	4	5	6	7	8	9	10	11	12	13	14	15	16
L1	55.5	66	76.5	87	97.5	108	118.5	129	139.5	150	160.5	171	181.5	192	202.5	213
L2	165	175.5	186	196.5	207	217.5	228	238.5	249	259.5	270	280.5	291	301.5	312	322.5
L3	187.5	200	212.5	225	237.5	237.5	250	262.5	275	287.5	300	300	312.5	325	337.5	350
L4	198	210.5	223	235.5	248	248	260.5	273	285.5	298	310.5	310.5	323	335.5	348	360.5

# S Series VQC1000/2000

Kit (Serial transmission) For EX126 Integrated-type (For Output) Serial Transmission System **IP67 compliant**

## VV5QC21 S kit (Serial transmission kit: EX126)

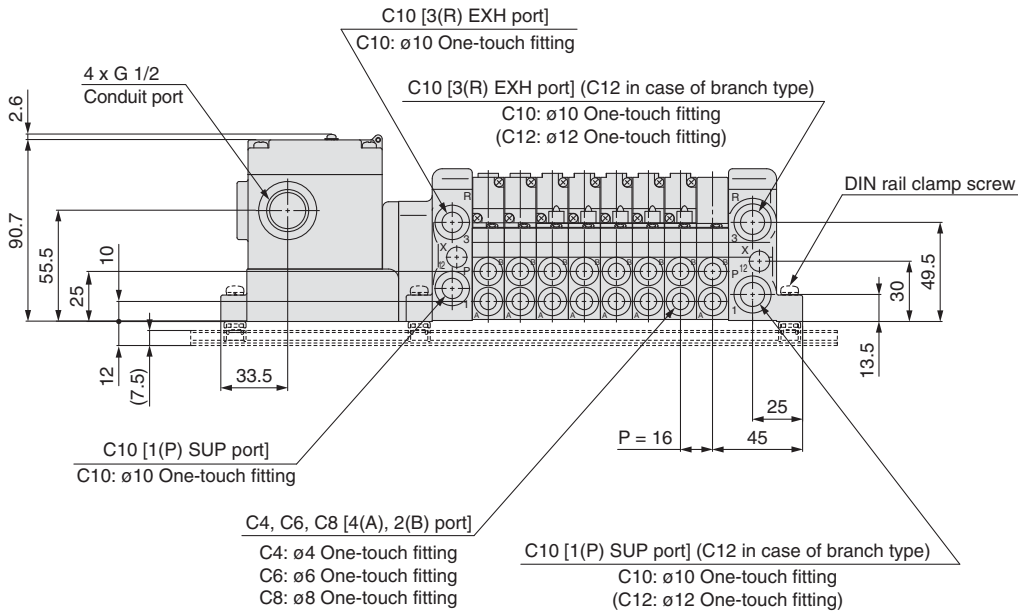

D side Stations 1 2 3 4 5 6 7 8 n U side

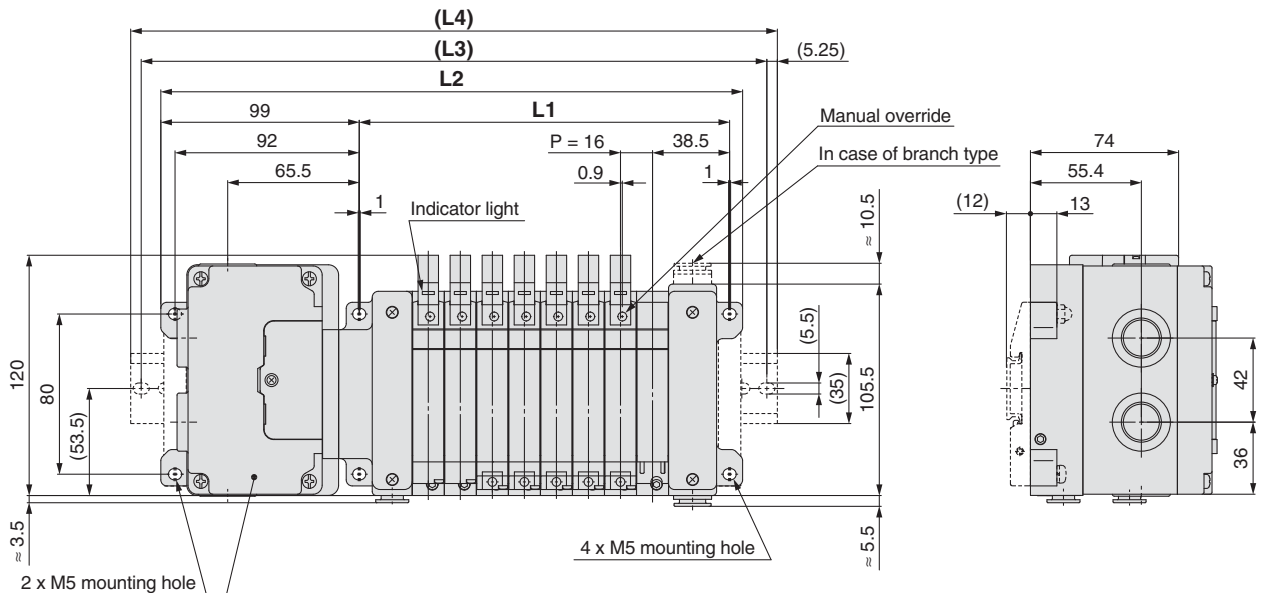

SI unit  
Use a drip proof plug assembly (AXT100-B04A) on the unused conduit port (G1/2).

The dashed lines indicate DIN rail mounting [-D] (with DIN rail mounting bracket).

Formula:  $L1 = 16n + 57$ ,  $L2 = 16n + 163$  n: Stations (Maximum 16 stations)

n	1	2	3	4	5	6	7	8	9	10	11	12	13	14	15	16
<b>L1</b>	73	89	105	121	137	153	169	185	201	217	233	249	265	281	297	313
<b>L2</b>	179	195	211	227	243	259	275	291	307	323	339	355	371	387	403	419
<b>L3</b>	200	225	237.5	250	262.5	287.5	300	312.5	337.5	371	362.5	375	400	412.5	425	450
<b>L4</b>	210.5	235.5	248	260.5	273	298	310.5	323	348	360.5	373	385.5	410.5	423	435.5	460.5

# Series VQC

## F Series VQC1000/2000 kit (D-sub connector) IP40 compliant

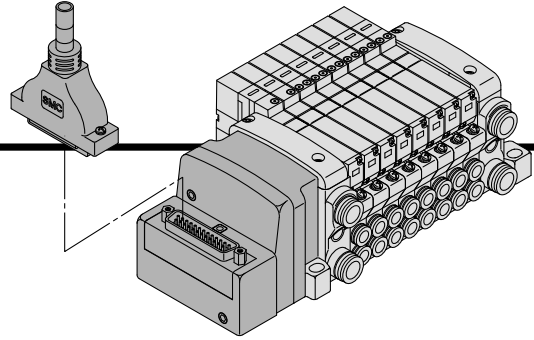

- Using our D-sub connector for electrical connections greatly reduces labour, while it also minimises wiring and saves space.
- We use a D-sub connector (25P) that conforms to MIL standards and is therefore widely compatible with many standard commercial models.
- Top or side entry for the connector can be changed freely, allowing for changes even after mounting, to meet any changing needs for space.

### Electrical Wiring Specifications

**D-sub connector**

As the standard electrical wiring specifications, double wiring (connected to SOL. A and SOL. B) is adopted for the internal wiring of each station for 12 stations or less, regardless of valve and option types. Mixed single and double wiring are available as an option. Refer to the below special wiring specifications (option).

**Lead wire colours for D-sub connector assembly (AXT100-DS25-015/030/050)**

Terminal no.	Polarity	Lead wire colour	Dot marking
Station 1 SOL.A	(-)	(+)	Black
Station 1 SOL.B	(-)	(+)	Yellow
Station 2 SOL.A	(-)	(+)	Brown
Station 2 SOL.B	(-)	(+)	Pink
Station 3 SOL.A	(-)	(+)	Red
Station 3 SOL.B	(-)	(+)	Blue
Station 4 SOL.A	(-)	(+)	Orange
Station 4 SOL.B	(-)	(+)	Purple
Station 5 SOL.A	(-)	(+)	Yellow
Station 5 SOL.B	(-)	(+)	Grey
Station 6 SOL.A	(-)	(+)	Pink
Station 6 SOL.B	(-)	(+)	Orange
Station 7 SOL.A	(-)	(+)	Blue
Station 7 SOL.B	(-)	(+)	Red
Station 8 SOL.A	(-)	(+)	Purple
Station 8 SOL.B	(-)	(+)	Brown
Station 9 SOL.A	(-)	(+)	Grey
Station 9 SOL.B	(-)	(+)	Pink
Station 10 SOL.A	(-)	(+)	White
Station 10 SOL.B	(-)	(+)	Grey
Station 11 SOL.A	(-)	(+)	White
Station 11 SOL.B	(-)	(+)	Black
Station 12 SOL.A	(-)	(+)	Yellow
Station 12 SOL.B	(-)	(+)	White
COM.	(+)	(-)	Orange

Note) When using the negative COM specification, use valves for negative COM.

### Special Wiring Specifications (Option)

(25P)

Mixed single and double wiring are available as an option. The maximum number of manifold stations is determined by the number of solenoids. Count one point for a single solenoid type and two points for a double solenoid type. The total number of solenoids (points) must not exceed 24.

### Cable Assembly

**AXT100-DS25-015/030/050**

(D-sub connector cable assembly can be ordered with manifolds.)  
Refer to "How to Order Manifold."

**Lead wire colours for D-sub connector cable assembly terminal numbers**

Terminal no.	Lead wire colour	Dot marking
1	Black	None
2	Brown	None
3	Red	None
4	Orange	None
5	Yellow	None
6	Pink	None
7	Blue	None
8	Purple	White
9	Grey	Black
10	White	Black
11	White	Red
12	Yellow	Red
13	Orange	Red
14	Yellow	Black
15	Pink	Black
16	Blue	White
17	Purple	None
18	Grey	None
19	Orange	Black
20	Red	White
21	Brown	White
22	Pink	Red
23	Grey	Red
24	Black	White
25	White	None

**D-sub connector cable assembly**

Cable length (L)	Assembly part no.	Note
1.5 m	AXT100-DS25-015	Cable 0.3 mm <sup>2</sup> x 25 cores
3 m	AXT100-DS25-030	
5 m	AXT100-DS25-050	

Note 1) When using a standard commercial connector, use a type 25P female connector conforming to MIL-C-24308.  
Note 2) Cannot be used for transfer wiring.  
Note 3) Lengths other than the above are also available. Please contact SMC for details.

**Electrical characteristics**

Item	Property
Conductor resistance Ω/km, 20°C	65 or less
Voltage limit V, 1 minute, AC	1000
Insulation resistance MΩ/km, 20°C	5 or more

Note) The minimum bending radius of the D-sub connector cable is 20 mm.

**Connector Manufacturers' Example**

- Fujitsu, Ltd.
- Japan Aviation Electronics Industry, Ltd.
- J.S.T. Mfg. Co., Ltd.
- Hirose Electric Co., Ltd.

# F Series VQC1000/2000 kit (D-sub connector) IP40 compliant

## VV5QC11

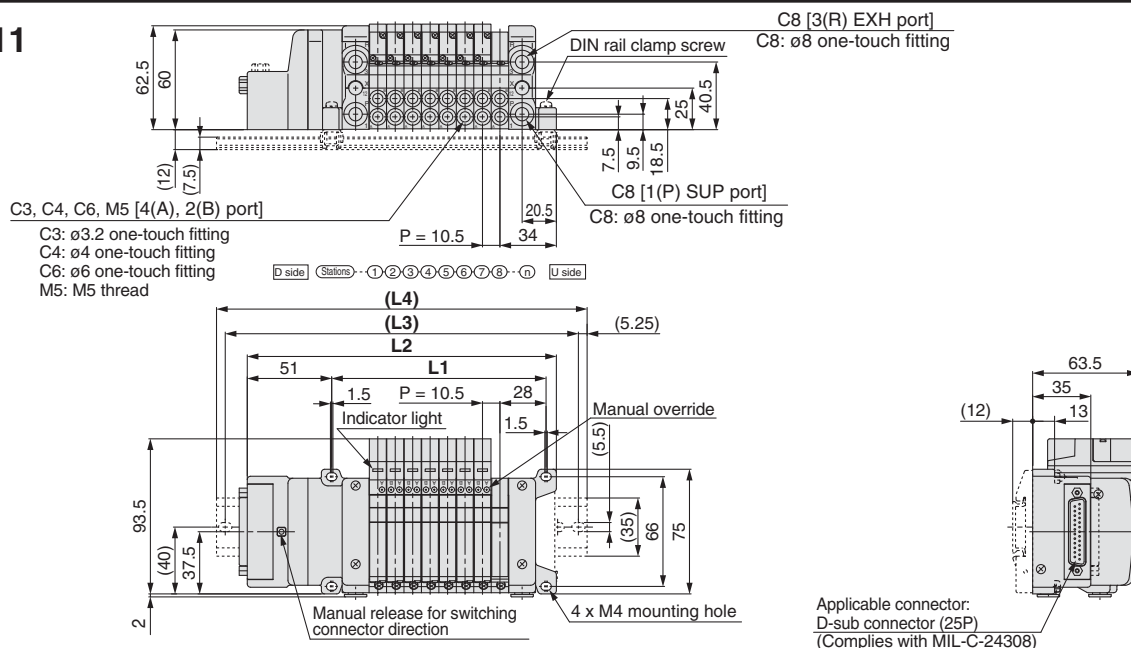

The dashed lines indicate the DIN rail mounting [-D] (with DIN rail mounting bracket).

Formula:  $L1 = 10.5n + 45$ ,  $L2 = 10.5n + 102$  n: Stations (Maximum 24 stations)

L \ n	1	2	3	4	5	6	7	8	9	10	11	12	13	14	15	16	17	18	19	20	21	22	23	24
L1	55.5	66	76.5	87	97.5	108	118.5	129	139.5	150	160.5	171	181.5	192	202.5	213	223.5	234	244.5	255	265.5	276	286.5	297
L2	112.5	123	133.5	144	154.5	165	175.5	186	196.5	207	217.5	228	238.5	249	259.5	270	280.5	291	301.5	312	322.5	333	343.5	354
L3	137.5	150	162.5	175	187.5	200	212.5	225	237.5	237.5	250	262.5	275	287.5	300	300	312.5	325	337.5	350	362.5	375	375	375
L4	148	160.5	173	185.5	185.5	198	210.5	223	235.5	248	248	260.5	273	285.5	298	310.5	310.5	323	335.5	348	360.5	373	385.5	385.5

## VV5QC21

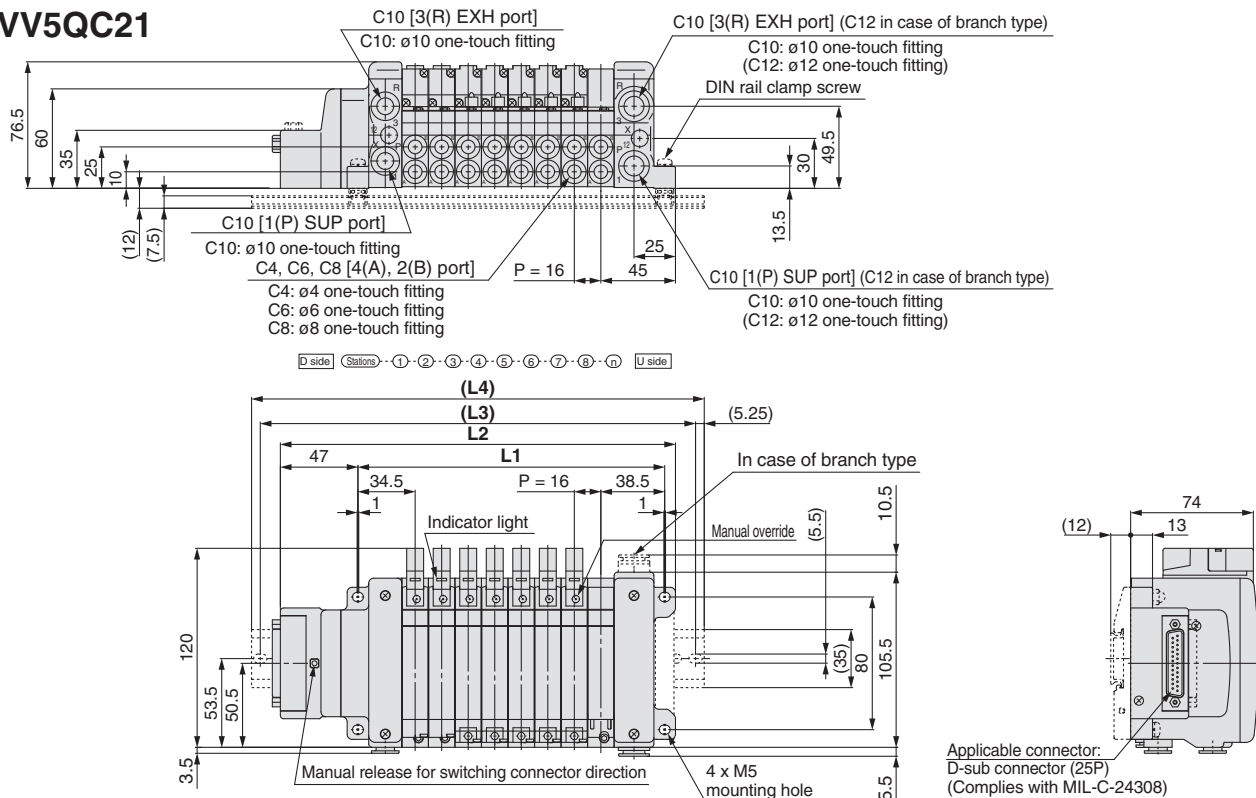

The dashed lines indicate the DIN rail mounting [-D] (with DIN rail mounting bracket).

Formula:  $L1 = 16n + 57$ ,  $L2 = 16n + 110.5$  n: Stations (Maximum 24 stations)

L \ n	1	2	3	4	5	6	7	8	9	10	11	12	13	14	15	16	17	18	19	20	21	22	23	24
L1	73	89	105	121	137	153	169	185	201	217	233	249	265	281	297	313	329	345	361	377	393	409	425	441
L2	126.5	142.5	158.5	174.5	190.5	206.5	222.5	238.5	254.5	270.5	286.5	302.5	318.5	334.5	350.5	366.5	382.5	398.5	414.5	430.5	446.5	462.5	478.5	494.5
L3	150	162.5	187.5	200	212.5	237.5	250	262.5	275	300	312.5	325	350	362.5	375	387.5	412.5	425	437.5	450	475	487.5	500	525
L4	160.5	173	198	210.5	223	248	260.5	273	285.5	310.5	323	335.5	360.5	373	385.5	398	423	435.5	448	460.5	485.5	498	510.5	535.5

# Series VQC

## P Series VQC1000/2000 kit (Flat ribbon cable) IP40 compliant

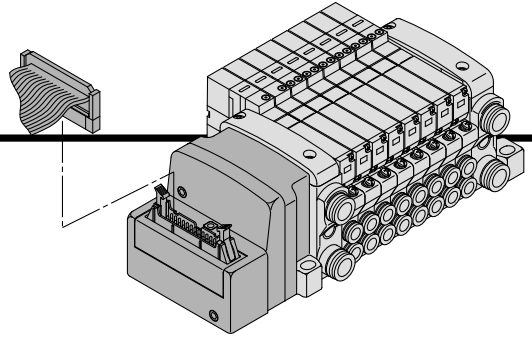

- Using our flat ribbon cable for electrical connections greatly reduces labour, while it also minimises wiring and saves space.
- We use flat ribbon cables whose connectors (26P and 20P) conform to MIL standards, and are therefore widely compatible with many standard commercial models.
- Top or side entry for the connector can be changed freely, allowing for changes even after mounting, to meet any changing needs for space.

### Electrical Wiring Specifications

**Flat ribbon cable connector**

Double wiring (connected to SOL. A and SOL. B) is adopted for the internal wiring of each station, regardless of valve and option types. Mixed single and double wiring are available as an option. Refer to the below special wiring specifications (option).

Connector terminal number

Triangle mark indicator position

<26P>				<20P>			
Station	Terminal no.	Polarity		Station	Terminal no.	Polarity	
Station 1	SOL.A	1	(-) (+)	Station 1	SOL.A	1	(-) (+)
	SOL.B	2	(+) (+)		SOL.B	2	(-) (+)
Station 2	SOL.A	3	(-) (+)	Station 2	SOL.A	3	(-) (+)
	SOL.B	4	(+) (+)		SOL.B	4	(-) (+)
Station 3	SOL.A	5	(-) (+)	Station 3	SOL.A	5	(-) (+)
	SOL.B	6	(+) (+)		SOL.B	6	(-) (+)
Station 4	SOL.A	7	(-) (+)	Station 4	SOL.A	7	(-) (+)
	SOL.B	8	(+) (+)		SOL.B	8	(-) (+)
Station 5	SOL.A	9	(-) (+)	Station 5	SOL.A	9	(-) (+)
	SOL.B	10	(+) (+)		SOL.B	10	(-) (+)
Station 6	SOL.A	11	(-) (+)	Station 6	SOL.A	11	(-) (+)
	SOL.B	12	(+) (+)		SOL.B	12	(-) (+)
Station 7	SOL.A	13	(-) (+)	Station 7	SOL.A	13	(-) (+)
	SOL.B	14	(+) (+)		SOL.B	14	(-) (+)
Station 8	SOL.A	15	(-) (+)	Station 8	SOL.A	15	(-) (+)
	SOL.B	16	(+) (+)		SOL.B	16	(-) (+)
Station 9	SOL.A	17	(-) (+)	Station 9	SOL.A	17	(-) (+)
	SOL.B	18	(+) (+)		SOL.B	18	(-) (+)
Station 10	SOL.A	19	(-) (+)	Station 10	COM.	19	(+) (-)
	SOL.B	20	(+) (+)		COM.	20	(+) (-)
Station 11	SOL.A	21	(-) (+)	Station 11			
	SOL.B	22	(+) (+)				
Station 12	SOL.A	23	(-) (+)	Station 12			
	SOL.B	24	(+) (+)				
	COM.	25	(+) (-)				
	COM.	26	(+) (-)				

Note) Positive COM spec. Negative COM spec.

Note) When using the negative COM specification, use valves for negative COM.

### Cable Assembly

**AXT100-FC<sup>20</sup><sub>26-3</sub>**

(Type 26P flat ribbon cable connector assembly can be ordered with manifolds. Refer to "How to Order Manifold.")

**Flat ribbon cable connector assembly**

Cable length (L)	Assembly part no.	
	26P	20P
1.5 m	AXT100-FC26-1	AXT100-FC20-1
3 m	AXT100-FC26-2	AXT100-FC20-2
5 m	AXT100-FC26-3	AXT100-FC20-3

Note 1) When using a standard commercial connector, use a type 26P connector conforming to MIL-C-83503 or a type 20P with strain relief.

Note 1) Cannot be used for transfer wiring.

Note 1) Lengths other than the above are also available. Please contact SMC for details.

**Connector Manufacturers' Example**

- Hirose Electric Co., Ltd.
- Sumitomo 3M Limited
- Fujitsu, Ltd.
- Japan Aviation Electronics Industry, Ltd.
- J.S.T. Mfg. Co., Ltd.
- Oki Electric Cable Co., Ltd.

### Special Wiring Specifications (Option)

Mixed single and double wiring are available as an option. The maximum number of manifold stations is determined by the number of solenoids. Count one point for a single solenoid type and two points for a double solenoid type. The total number of solenoids (points) must not exceed 24.

(26P) (20P)



# P Series VQC1000/2000 kit (Flat ribbon cable) IP40 compliant

## VV5QC11

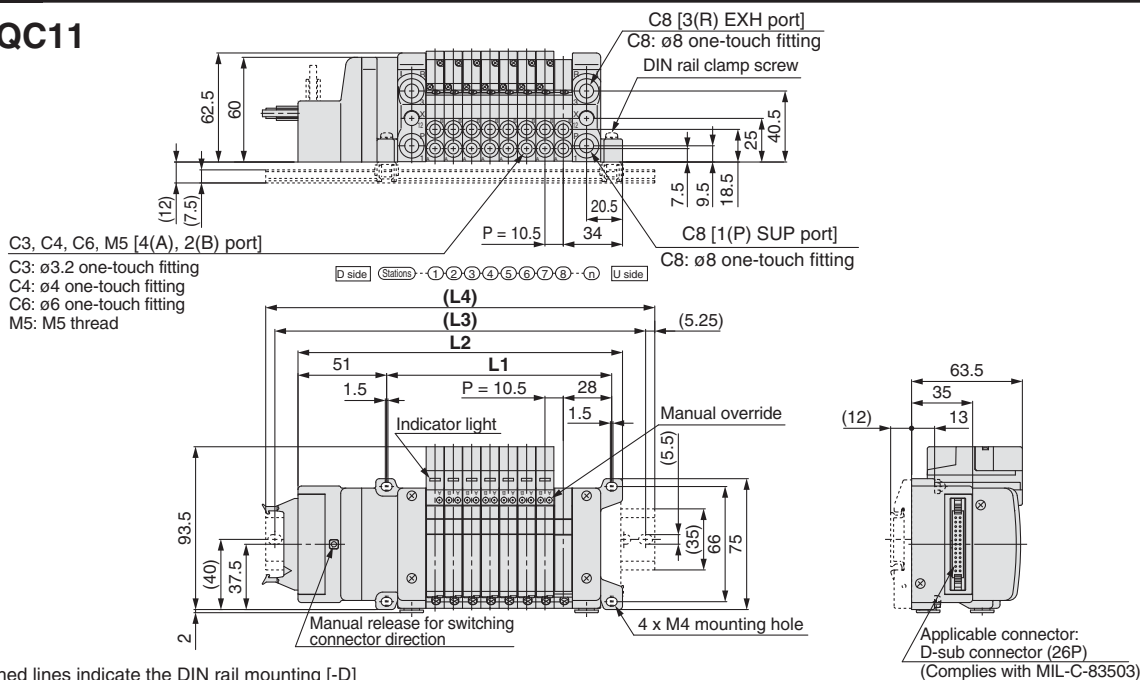

The dashed lines indicate the DIN rail mounting [-D] (with DIN rail mounting bracket).

Formula:  $L1 = 10.5n + 45$ ,  $L2 = 10.5n + 102$  n: Stations (Maximum 24 stations)

L \ n	1	2	3	4	5	6	7	8	9	10	11	12	13	14	15	16	17	18	19	20	21	22	23	24
L1	55.5	66	76.5	87	97.5	108	118.5	129	139.5	150	160.5	171	181.5	192	202.5	213	223.5	234	244.5	255	265.5	276	286.5	297
L2	112.5	123	133.5	144	154.5	165	175.5	186	196.5	207	217.5	228	238.5	249	259.5	270	280.5	291	301.5	312	322.5	333	343.5	354
L3	137.5	150	162.5	175	187.5	200	212.5	225	237.5	250	262.5	275	287.5	300	300	312.5	325	337.5	350	362.5	375	375	375	375
L4	148	160.5	173	185.5	198.5	211.5	224	236.5	249	261.5	274	286.5	298.5	310.5	310.5	323	335.5	348	360.5	373	385.5	385.5	385.5	385.5

## VV5QC21

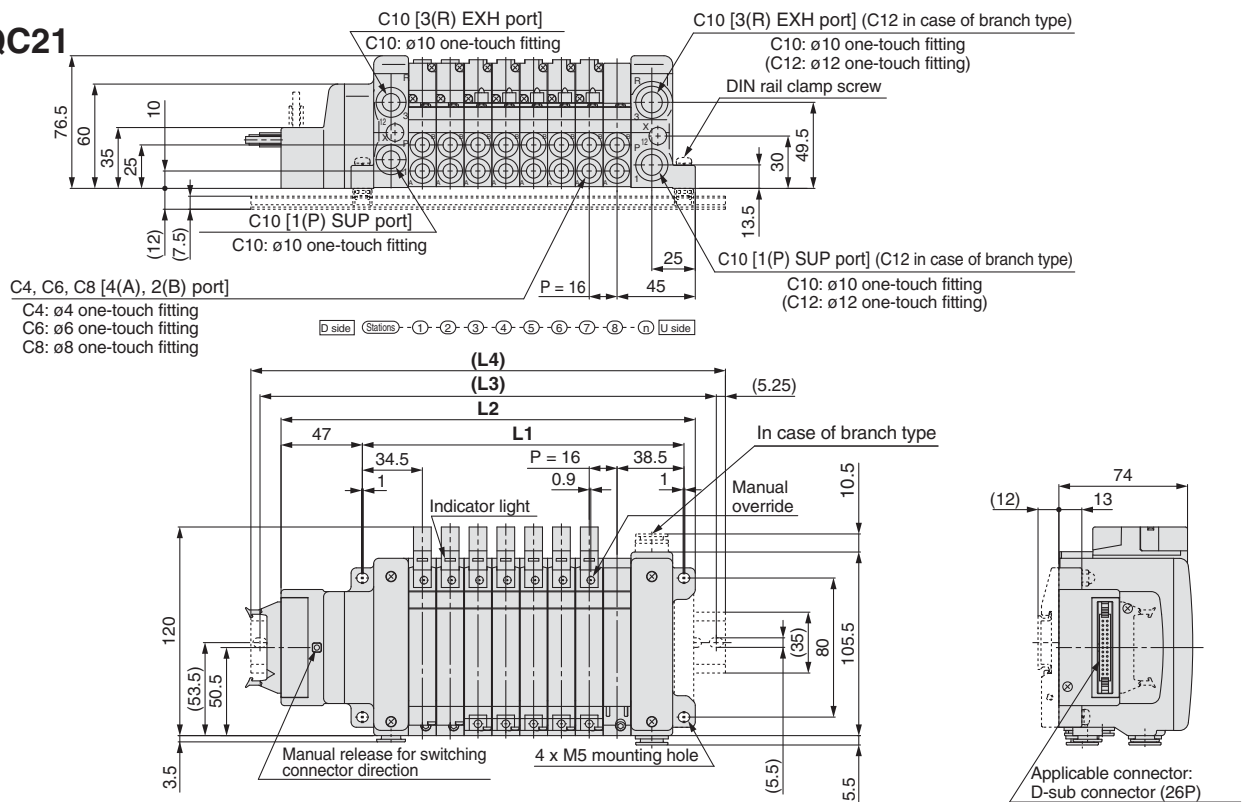

The dashed lines indicate the DIN rail mounting [-D] (with DIN rail mounting bracket).

Formula:  $L1 = 16n + 57$ ,  $L2 = 16n + 110.5$  n: Stations (Maximum 24 stations)

L \ n	1	2	3	4	5	6	7	8	9	10	11	12	13	14	15	16	17	18	19	20	21	22	23	24
L1	73	89	105	121	137	153	169	185	201	217	233	249	265	281	297	313	329	345	361	377	393	409	425	441
L2	126.5	142.5	158.5	174.5	190.5	206.5	222.5	238.5	254.5	270.5	286.5	302.5	318.5	334.5	350.5	366.5	382.5	398.5	414.5	430.5	446.5	462.5	478.5	494.5
L3	150	162.5	187.5	200	212.5	237.5	250	262.5	275	300	312.5	325	350	362.5	375	387.5	412.5	425	437.5	450	475	487.5	500	525
L4	160.5	173	198	210.5	223	248	260.5	273	285.5	310.5	323	335.5	360.5	373	385.5	398	423	435.5	448	460.5	485.5	498	510.5	535.5

# Series VQC

## T Series VQC1000/2000 kit (Terminal block box) IP67 compliant

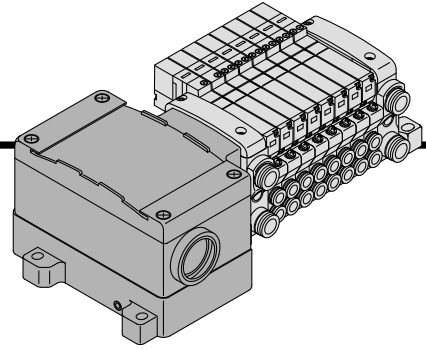

- This kit has a small terminal block inside a junction box. The electrical entry port of a G 3/4 permits connection of conduit fittings.

### Terminal Block Connection

#### Step 1. Removing the terminal block cover

Loosen the 4 mounting screws (M4) and remove the terminal block cover.

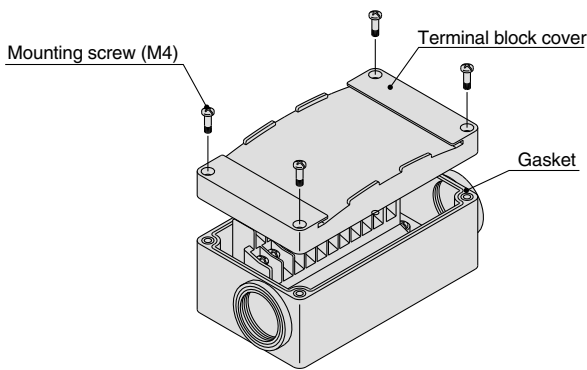

#### Step 3. Mounting the terminal block cover

Securely tighten the screws to the torque shown in the table below, after confirming that the gasket is installed correctly.

Proper tightening torque (N·m)
0.7 to 1.2

#### Step 2. The diagram below shows the terminal block wiring.

**All stations are provided with double wiring regardless of the valves which are mounted.**

Connect each wire to the power supply side, according to the markings provided inside the terminal block.

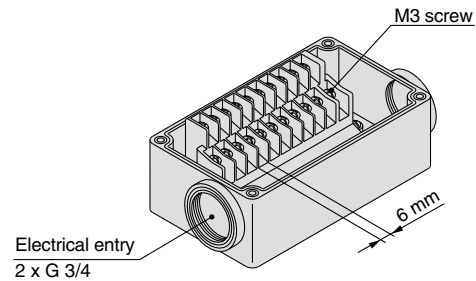

- Applicable crimped terminal: 1.25-3S, 1.25Y-3, 1.25Y-3N, 1.25Y-3.5
- Name plate: VVQ5000-N-T
- Drip-proof plug assembly (for G 3/4): AXT100-B06A

### Electrical Wiring Specifications (IP67 compatible)

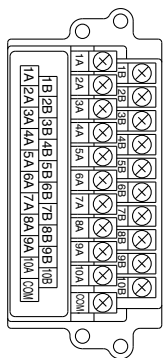

Double wiring (connected to SOL. A and SOL. B) is adopted for the internal wiring of each station, regardless of valve and option types. Mixed single and double wiring are available as an option.

Note) When using the negative COM specification, use valves for negative COM.

	Terminal no.	Polarity
Station 1	SOL.A 1A	(-) (+)
	SOL.B 1B	(-) (+)
Station 2	SOL.A 2A	(-) (+)
	SOL.B 2B	(-) (+)
Station 3	SOL.A 3A	(-) (+)
	SOL.B 3B	(-) (+)
Station 4	SOL.A 4A	(-) (+)
	SOL.B 4B	(-) (+)
Station 5	SOL.A 5A	(-) (+)
	SOL.B 5B	(-) (+)
Station 6	SOL.A 6A	(-) (+)
	SOL.B 6B	(-) (+)
Station 7	SOL.A 7A	(-) (+)
	SOL.B 7B	(-) (+)
Station 8	SOL.A 8A	(-) (+)
	SOL.B 8B	(-) (+)
Station 9	SOL.A 9A	(-) (+)
	SOL.B 9B	(-) (+)
Station 10	SOL.A 10A	(-) (+)
	SOL.B 10B	(-) (+)
	COM	(+) (-)

Positive COM spec.      Negative COM spec. <sup>Note)</sup>

### Special Wiring Specifications (Option)

Mixed single and double wiring are available as an option. The maximum number of manifold stations is determined by the number of solenoids. Count one point for a single solenoid type and two points for a double solenoid type. The total number of solenoids (points) must not exceed 20.

#### 1. How to Order

Indicate option symbol "K" in the manifold part number and be sure to specify station positions for single or double wiring on the manifold specification sheet.

#### 2. Wiring specifications

Connector terminal numbers are connected from solenoid station 1 on the A side in the order indicated by the arrows without skipping any terminal numbers.

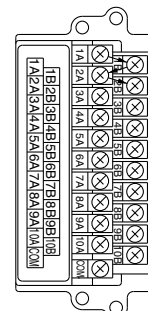

# T Series VQC1000/2000 kit (Terminal block box) IP67 compliant

## VV5QC11

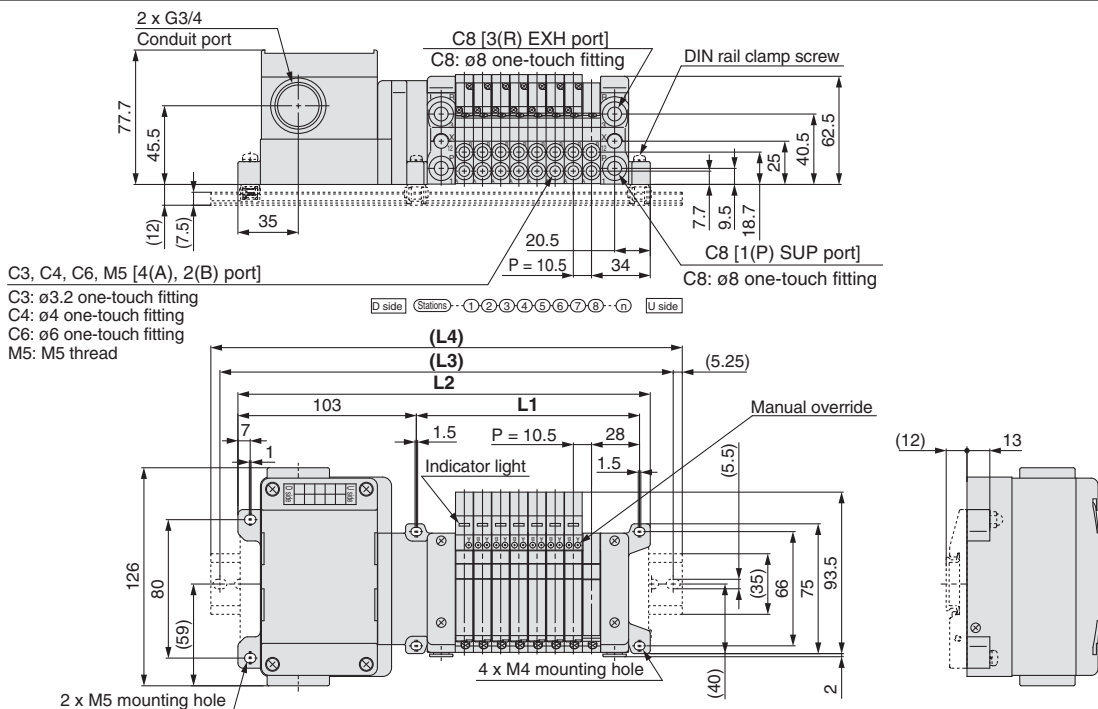

The dashed lines indicate DIN rail mounting [-D] (with DIN rail mounting bracket).

Formula:  $L1 = 10.5n + 45$ ,  $L2 = 10.5n + 154.5$  n: Stations (Maximum 20 stations)

L \ n	1	2	3	4	5	6	7	8	9	10	11	12	13	14	15	16	17	18	19	20
<b>L1</b>	55.5	66	76.5	87	97.5	108	118.5	129	139.5	150	160.5	171	181.5	192	202.5	213	223.5	234	244.5	255
<b>L2</b>	165	175.5	186	196.5	207	217.5	228	238.5	249	259.5	270	280.5	291	301.5	312	322.5	333	343.5	354	364.5
<b>L3</b>	187.5	200	212.5	225	237.5	237.5	250	262.5	275	287.5	300	300	312.5	325	337.5	350	362.5	375	375	387.5
<b>L4</b>	198	210.5	223	235.5	248	248	260.5	273	285.5	298	310.5	310.5	323	335.5	348	360.5	373	385.5	385.5	398

## VV5QC21

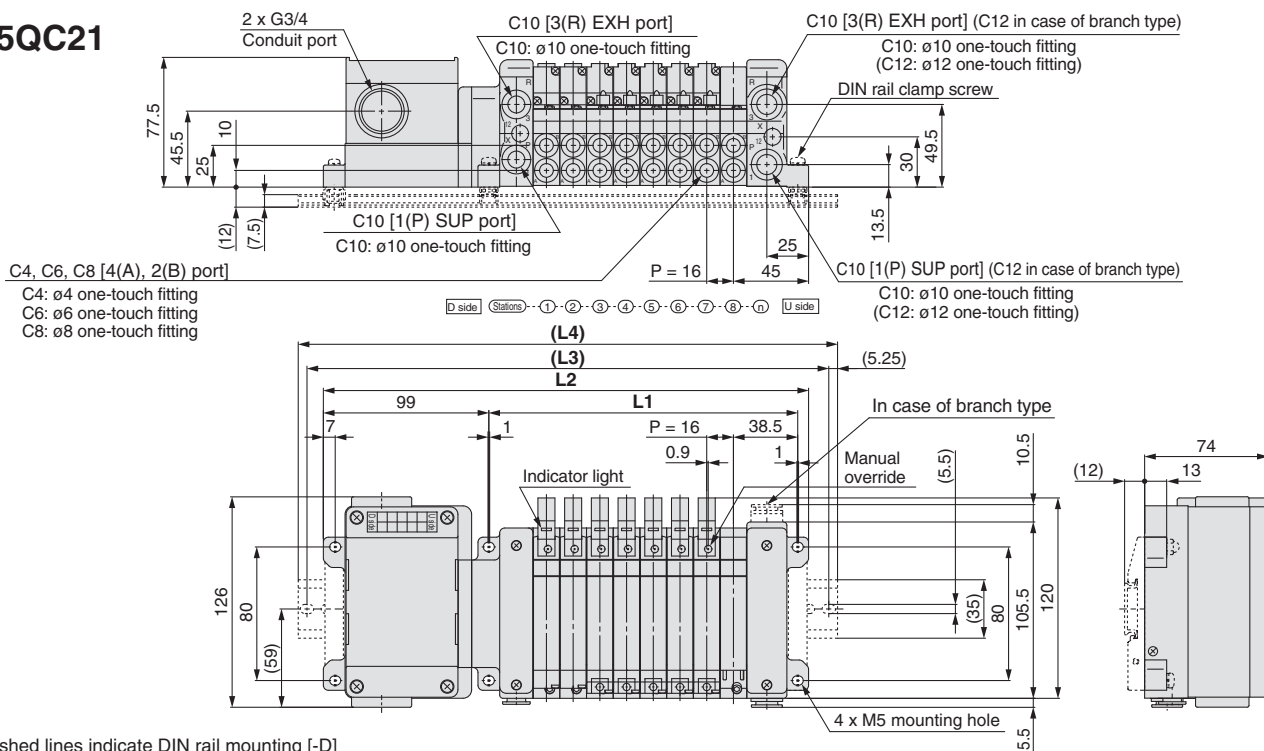

The dashed lines indicate DIN rail mounting [-D] (with DIN rail mounting bracket).

Formula:  $L1 = 16n + 57$ ,  $L2 = 16n + 163$  n: Stations (Maximum 20 stations)

L \ n	1	2	3	4	5	6	7	8	9	10	11	12	13	14	15	16	17	18	19	20
<b>L1</b>	73	89	105	121	137	153	169	185	201	217	233	249	265	281	297	313	329	345	361	377
<b>L2</b>	179	195	211	227	243	259	275	291	307	323	339	355	371	387	403	419	435	451	467	483
<b>L3</b>	200	225	237.5	250	262.5	287.5	300	312.5	337.5	350	362.5	375	400	412.5	425	450	462.5	475	487.5	512.5
<b>L4</b>	210.5	235.5	248	260.5	273	298	310.5	323	348	360.5	373	385.5	410.5	423	435.5	460.5	473	485.5	498	523

# Series VQC

## Series VQC1000/2000 kit (Lead wire) IP67 compliant

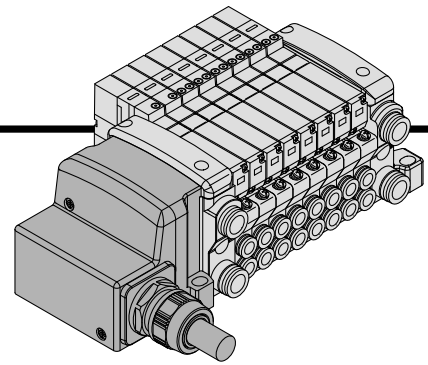

- Direct electrical entry type
- IP67 enclosure is available with use of cables with sheath and waterproof connectors.

### Electrical Wiring Specifications

#### Lead wire specifications

Lead wire  
0.3 mm<sup>2</sup> x 25 cores

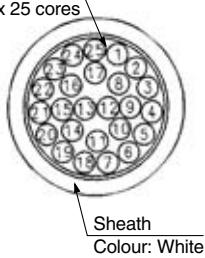

As the standard electrical wiring specifications, double wiring (connected to SOL. A and SOL. B) is adopted for the internal wiring of each station for 12 stations or less, regardless of valve and option types.

Mixed single and double wiring are available as an option. Refer to the below special wiring specifications (option).

#### Lead wire length

VV5QC11-08 C6 LD 0

#### Lead wire length

0	0.6 m
1	1.5 m
2	3.0 m

#### Electrical characteristics

Item	Property
Conductor resistance Ω/km, 20°C	65 or less
Voltage limit V, 1 minute, AC	1000
Insulation resistance MΩ/km, 20°C	5 or more

Note) Cannot be used for transfer wiring.  
The minimum bending radius of the cable is 20 mm.

	Terminal no.	Polarity	Lead wire colour	Dot marking
Station 1	SOL.A 1	(-) (+)	Black	None
	SOL.B 14	(-) (+)	Yellow	Black
Station 2	SOL.A 2	(-) (+)	Brown	None
	SOL.B 15	(-) (+)	Pink	Black
Station 3	SOL.A 3	(-) (+)	Red	None
	SOL.B 16	(-) (+)	Blue	White
Station 4	SOL.A 4	(-) (+)	Orange	None
	SOL.B 17	(-) (+)	Purple	None
Station 5	SOL.A 5	(-) (+)	Yellow	None
	SOL.B 18	(-) (+)	Grey	None
Station 6	SOL.A 6	(-) (+)	Pink	None
	SOL.B 19	(-) (+)	Orange	Black
Station 7	SOL.A 7	(-) (+)	Blue	None
	SOL.B 20	(-) (+)	Red	White
Station 8	SOL.A 8	(-) (+)	Purple	White
	SOL.B 21	(-) (+)	Brown	White
Station 9	SOL.A 9	(-) (+)	Grey	Black
	SOL.B 22	(-) (+)	Pink	Red
Station 10	SOL.A 10	(-) (+)	White	Black
	SOL.B 23	(-) (+)	Grey	Red
Station 11	SOL.A 11	(-) (+)	White	Red
	SOL.B 24	(-) (+)	Black	White
Station 12	SOL.A 12	(-) (+)	Yellow	Red
	SOL.B 25	(-) (+)	White	None
	COM. 13	(+) (-) Note)	Orange	Red

Positive COM spec.      Negative COM spec.

Note) When using the negative COM specification, use valves for negative COM.

### Special Wiring Specifications (Option)

Mixed single and double wiring are available as an option. The maximum number of manifold stations is determined by the number of solenoids. Count one point for a single solenoid type and two points for a double solenoid type. The total number of solenoids (points) must not exceed 24.

# Series VQC1000/2000

kit (Lead wire) IP67 compliant

## VV5QC11

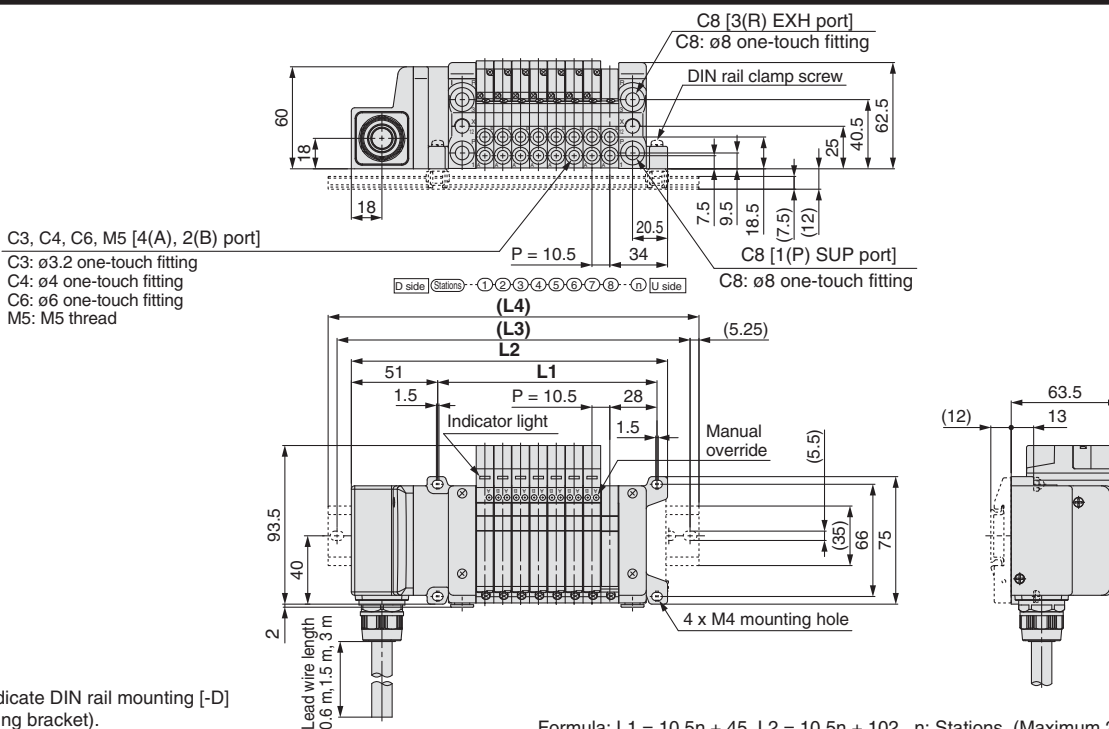

The dashed lines indicate DIN rail mounting [-D] (with DIN rail mounting bracket).

Formula:  $L1 = 10.5n + 45$ ,  $L2 = 10.5n + 102$  n: Stations (Maximum 24 stations)

L \ n	1	2	3	4	5	6	7	8	9	10	11	12	13	14	15	16	17	18	19	20	21	22	23	24
L1	55.5	66	76.5	87	97.5	108	118.5	129	139.5	150	160.5	171	181.5	192	202.5	213	223.5	234	244.5	255	265.5	276	286.5	297
L2	112.5	123	133.5	144	154.5	165	175.5	186	196.5	207	217.5	228	238.5	249	259.5	270	280.5	291	301.5	312	322.5	333	343.5	354
L3	137.5	150	162.5	175	187.5	200	212.5	225	237.5	250	262.5	275	287.5	300	300	312.5	325	337.5	350	362.5	375	375	375	375
L4	148	160.5	173	185.5	198	210.5	223	235.5	248	260.5	273	285.5	298	310.5	310.5	323	335.5	348	360.5	373	385.5	385.5	385.5	385.5

## VV5QC21

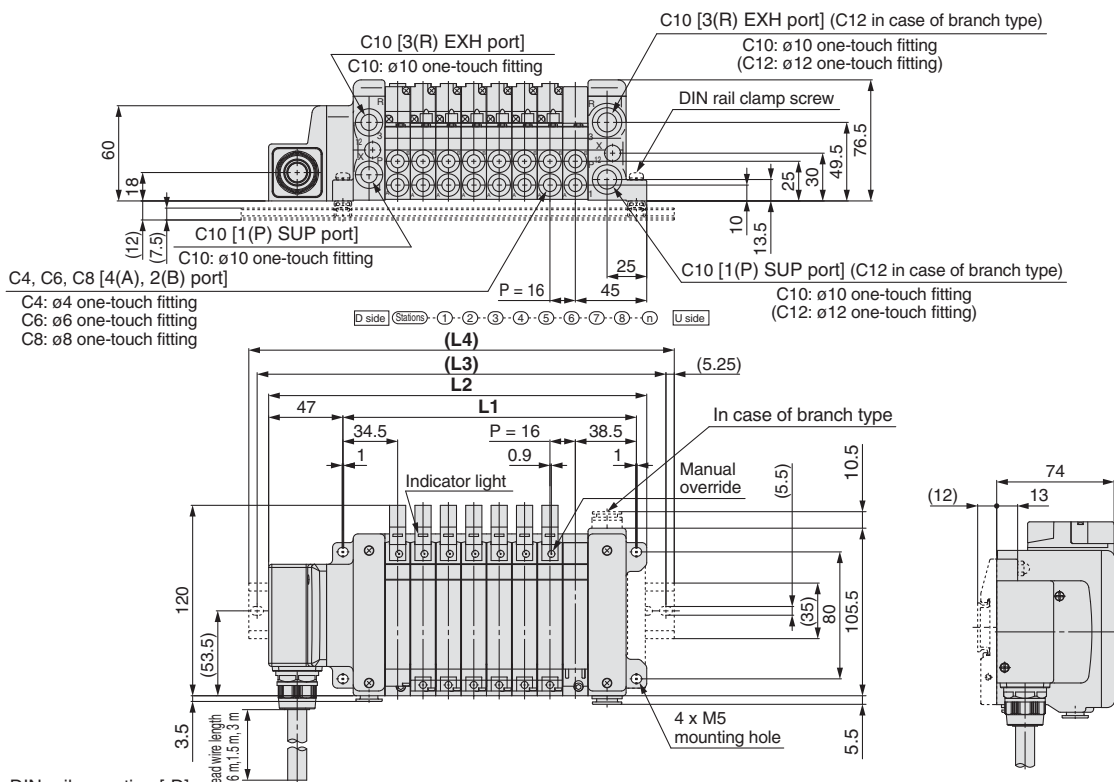

The dashed lines indicate DIN rail mounting [-D] (with DIN rail mounting bracket).

Formula:  $L1 = 16n + 57$ ,  $L2 = 16n + 110.5$  n: Stations (Maximum 24 stations)

L \ n	1	2	3	4	5	6	7	8	9	10	11	12	13	14	15	16	17	18	19	20	21	22	23	24
L1	73	89	105	121	137	153	169	185	201	217	233	249	265	281	297	313	329	345	361	377	393	409	425	441
L2	126.5	142.5	158.5	174.5	190.5	206.5	222.5	238.5	254.5	270.5	286.5	302.5	318.5	334.5	350.5	366.5	382.5	398.5	414.5	430.5	446.5	462.5	478.5	494.5
L3	150	162.5	187.5	200	212.5	237.5	250	262.5	275	300	312.5	325	350	362.5	375	387.5	412.5	425	437.5	450	475	487.5	500	525
L4	160.5	173	198	210.5	223	248	260.5	273	285.5	310.5	323	335.5	360.5	373	385.5	398	423	435.5	448	460.5	485.5	498	510.5	535.5



## M Series VQC1000/2000 kit (Circular connector) IP67 compliant

- Use of circular connectors helps streamline wiring procedure to save labour.
- IP67 enclosure is available with use of waterproof circular connectors.

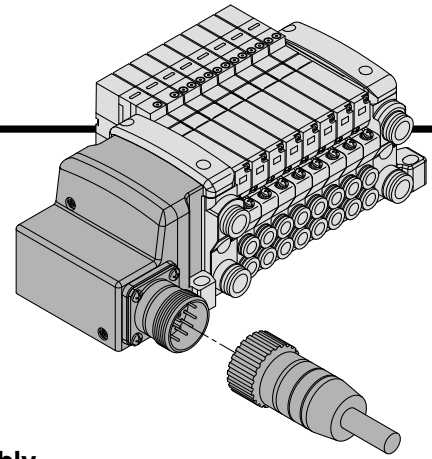

### Electrical Wiring Specifications

#### Circular connector

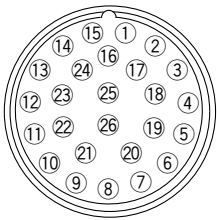

Double wiring (connected to SOL.A and SOL.B) is used for the internal wiring of each station, regardless of valve and option types. Mixed single and double wiring are available as an option. Refer to the below special wiring specifications (option).

	Terminal no.	Polarity	
Station 1	SOL.A 1	(-)	(+)
	SOL.B 2	(-)	(+)
Station 2	SOL.A 3	(-)	(+)
	SOL.B 4	(-)	(+)
Station 3	SOL.A 5	(-)	(+)
	SOL.B 6	(-)	(+)
Station 4	SOL.A 7	(-)	(+)
	SOL.B 8	(-)	(+)
Station 5	SOL.A 9	(-)	(+)
	SOL.B 10	(-)	(+)
Station 6	SOL.A 11	(-)	(+)
	SOL.B 12	(-)	(+)
Station 7	SOL.A 13	(-)	(+)
	SOL.B 14	(-)	(+)
Station 8	SOL.A 15	(-)	(+)
	SOL.B 16	(-)	(+)
Station 9	SOL.A 17	(-)	(+)
	SOL.B 18	(-)	(+)
Station 10	SOL.A 19	(-)	(+)
	SOL.B 20	(-)	(+)
Station 11	SOL.A 21	(-)	(+)
	SOL.B 22	(-)	(+)
Station 12	SOL.A 23	(-)	(+)
	SOL.B 24	(-)	(+)
	COM. 25	(+)	(-)
	COM. 26	(+)	(-)

Note)  
**Positive COM spec.**   **Negative COM spec.**

Note) When using the negative COM specification, use valves for negative COM.

### Special Wiring Specifications (Option)

Mixed single and double wiring are available as an option. The maximum number of manifold stations is determined by the number of solenoids. Count one point for a single solenoid type and two points for a double solenoid type. The total number of solenoids (points) must not exceed 24.

### Cable Assembly

**015**  
**AXT100-MC26-030**  
**050**

(Type 26P circular connector cable assembly can be ordered with manifolds. Refer to "How to Order Manifold.")

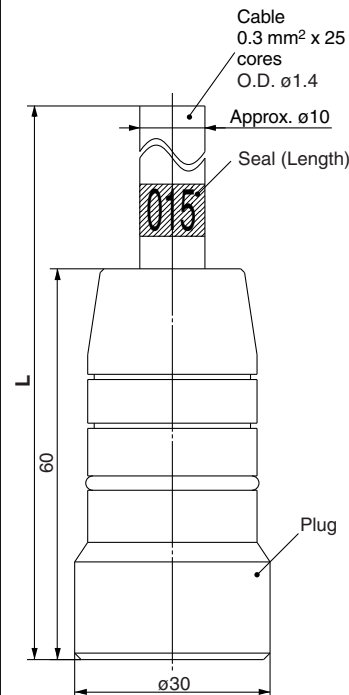
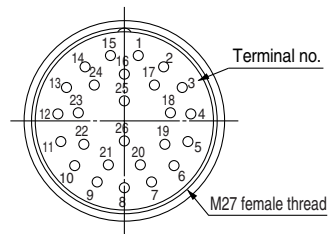

#### Lead wire colours for circular connector cable assembly terminal numbers

Terminal no.	Lead wire colour	Dot marking
1	Black	None
2	Brown	None
3	Red	None
4	Orange	None
5	Yellow	None
6	Pink	None
7	Blue	None
8	Purple	White
9	Grey	Black
10	White	Black
11	White	Red
12	Yellow	Red
13	Orange	Red
14	Yellow	Black
15	Pink	Black
16	Blue	White
17	Purple	None
18	Grey	None
19	Orange	Black
20	Red	White
21	Brown	White
22	Pink	Red
23	Grey	Red
24	Black	White
25	White	None
26	White	None

#### Electrical characteristics

Item	Property
Conductor resistance Ω/km, 20°C	65 or less
Voltage limit V, 1 minute, AC	1000
Insulation resistance MΩ/km, 20°C	5 or more

Note) The minimum bending radius of the circular connector cable is 20 mm.

#### Circular connector cable assembly

Cable length (L)	Assembly part no.
	26P
1.5 m	AXT100-MC26-015
3 m	AXT100-MC26-030
5 m	AXT100-MC26-050

Note 1) Cannot be used for transfer wiring.  
Note 2) Lengths other than the above are also available. Please contact SMC for details.

# M Series VQC1000/2000 kit (Circular connector) IP67 compliant

## VV5QC11

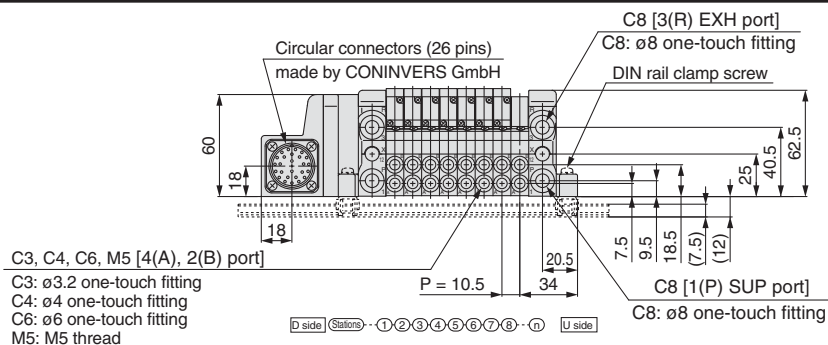

AXT100-MC26-050: 5 m  
Circular connector cable assembly  
AXT100-MC26-015: 1.5 m  
AXT100-MC26-030: 3 m

The dashed lines indicate  
DIN rail mounting [-D]  
(with DIN rail mounting bracket).

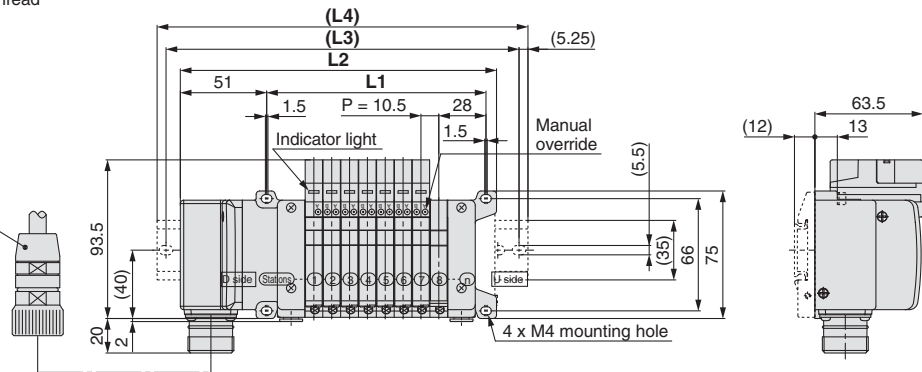

Formula:  $L1 = 10.5n + 45$ ,  $L2 = 10.5n + 102$  n: Stations (Maximum 24 stations)

L \ n	1	2	3	4	5	6	7	8	9	10	11	12	13	14	15	16	17	18	19	20	21	22	23	24
L1	55.5	66	76.5	87	97.5	108	118.5	129	139.5	150	160.5	171	181.5	192	202.5	213	223.5	234	244.5	255	265.5	276	286.5	297
L2	112.5	123	133.5	144	154.5	165	175.5	186	196.5	207	217.5	228	238.5	249	259.5	270	280.5	291	301.5	312	322.5	333	343.5	354
L3	137.5	150	162.5	175	187.5	200	212.5	225	237.5	250	262.5	275	287.5	300	300	312.5	325	337.5	350	362.5	375	375	375	375
L4	148	160.5	173	185.5	198	210.5	223	235.5	248	260.5	273	285.5	298	310.5	310.5	323	335.5	348	360.5	373	385.5	385.5	385.5	385.5

## VV5QC21

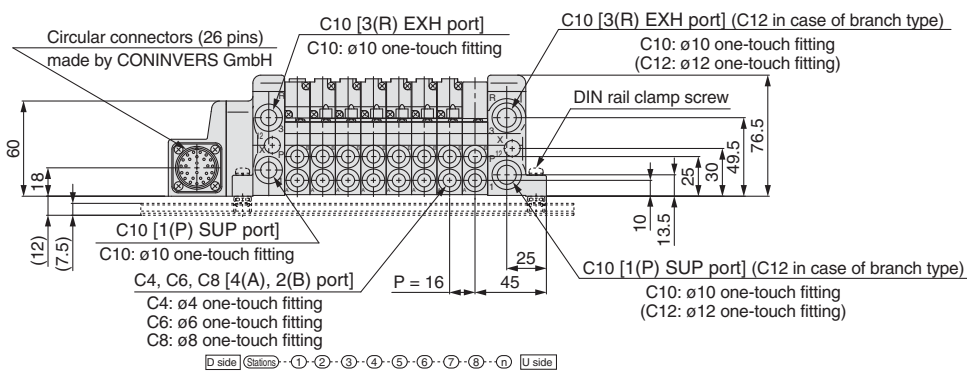

Circular connector cable assembly  
AXT100-MC26-015: 1.5 m  
AXT100-MC26-030: 3 m  
AXT100-MC26-050: 5 m

The dashed lines indicate  
DIN rail mounting [-D]  
(with DIN rail mounting bracket).

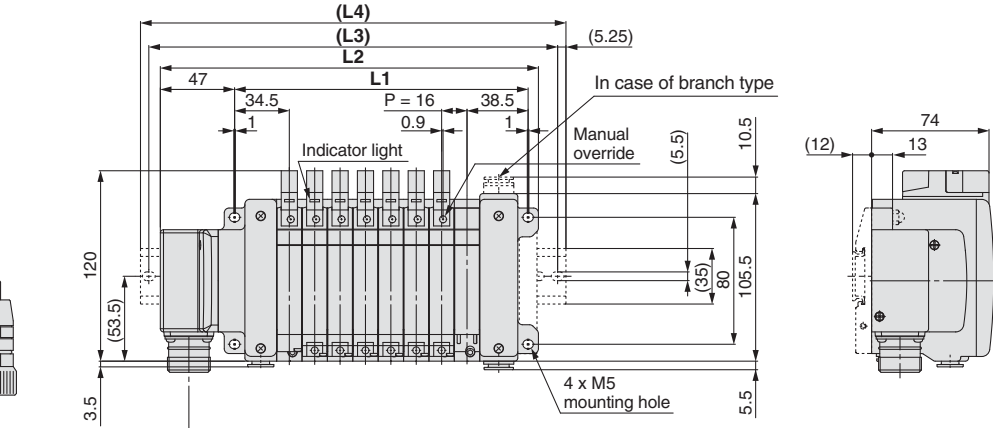

Formula:  $L1 = 16n + 57$ ,  $L2 = 16n + 110.5$  n: Stations (Maximum 24 stations)

L \ n	1	2	3	4	5	6	7	8	9	10	11	12	13	14	15	16	17	18	19	20	21	22	23	24
L1	73	89	105	121	137	153	169	185	201	217	233	249	265	281	297	313	329	345	361	377	393	409	425	441
L2	126.5	142.5	158.5	174.5	190.5	206.5	222.5	238.5	254.5	270.5	286.5	302.5	318.5	334.5	350.5	366.5	382.5	398.5	414.5	430.5	446.5	462.5	478.5	494.5
L3	150	162.5	187.5	200	212.5	237.5	250	262.5	275	300	312.5	325	350	362.5	375	387.5	412.5	425	437.5	450	475	487.5	500	525
L4	160.5	173	198	210.5	223	248	260.5	273	285.5	310.5	323	335.5	360.5	373	385.5	398	423	435.5	448	460.5	485.5	498	510.5	535.5

# Series VQC1000/2000

## Construction

### VQC1000 Plug-in Unit: Main Parts/Replacement Parts

#### Metal seal

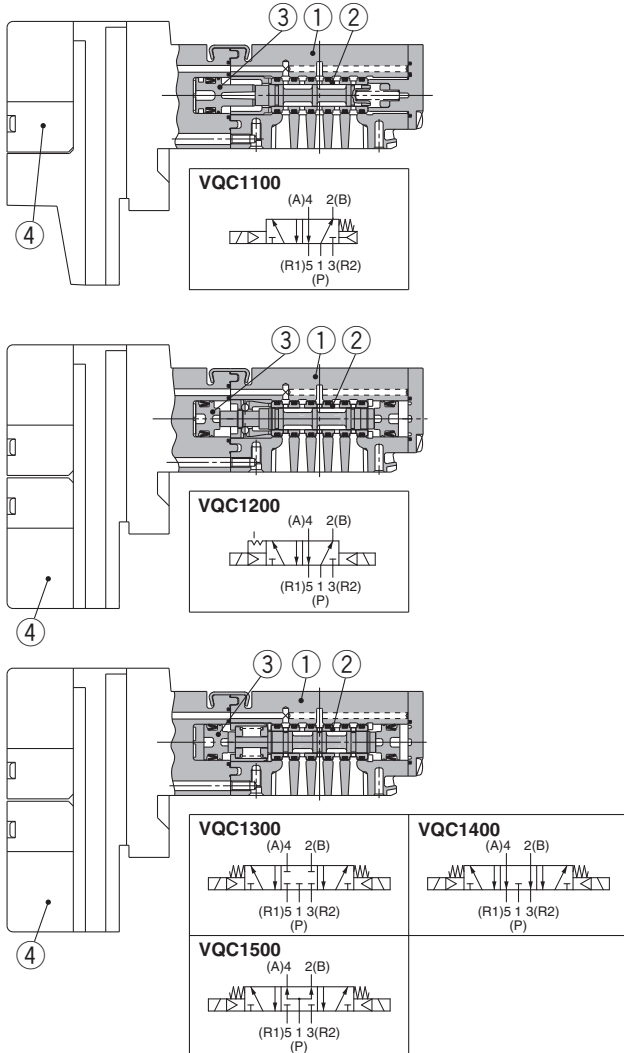

#### Rubber seal

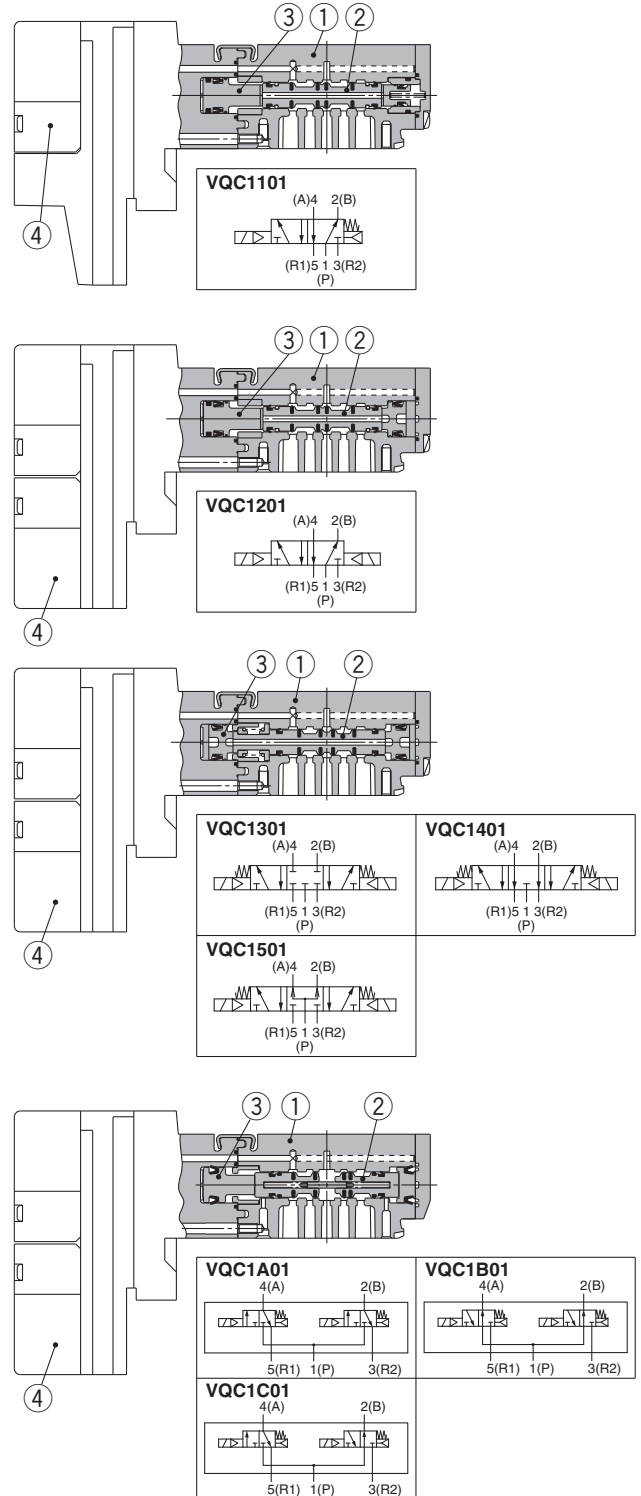

#### Component Parts

No.	Description	Material	Note
1	Body	Zinc die-casted	
2	Spool/Sleeve	Stainless steel	
3	Piston	Resin	
4	Pilot valve assembly	—	

Note) Refer to page 48 for "How to Order Pilot Valve Assembly."

#### Component Parts

No.	Description	Material	Note
1	Body	Zinc die-casted	
2	Spool valve	Aluminum, HNBR	
3	Piston	Resin	
4	Pilot valve assembly	—	

Note) Refer to page 48 for "How to Order Pilot Valve Assembly."

### VQC2000 Plug-in Unit: Main Parts/Replacement Parts

#### Metal seal

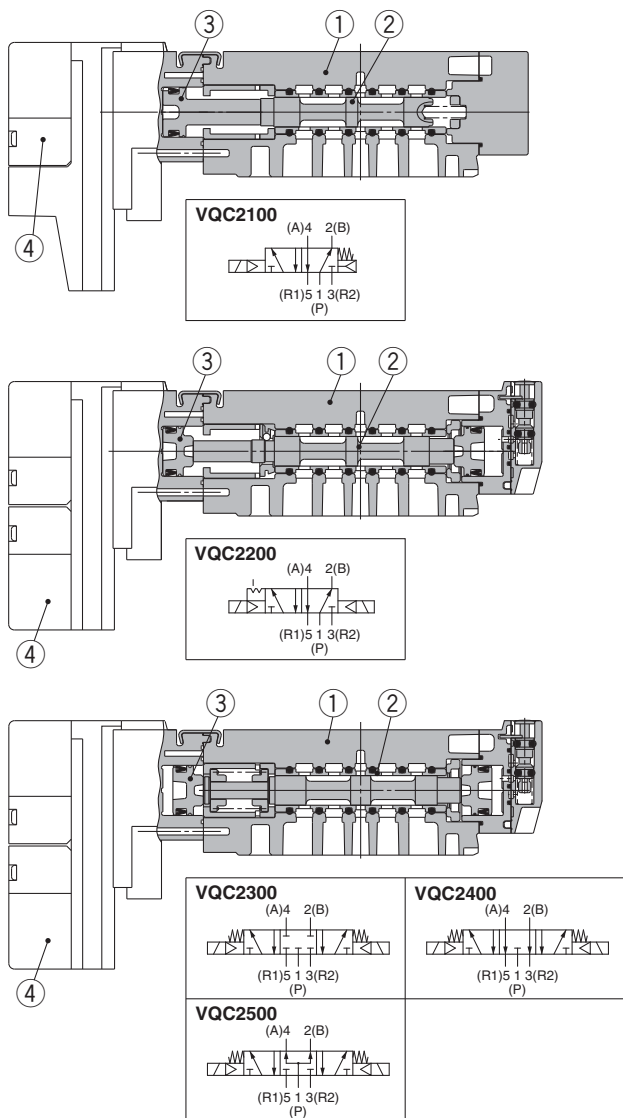

#### Component Parts

No.	Description	Material	Note
1	Body	Zinc die-casted	
2	Spool/Sleeve	Stainless steel	
3	Piston	Resin	
4	Pilot valve assembly	—	

Note) Refer to page 48 for "How to Order Pilot Valve Assembly."

#### Rubber seal

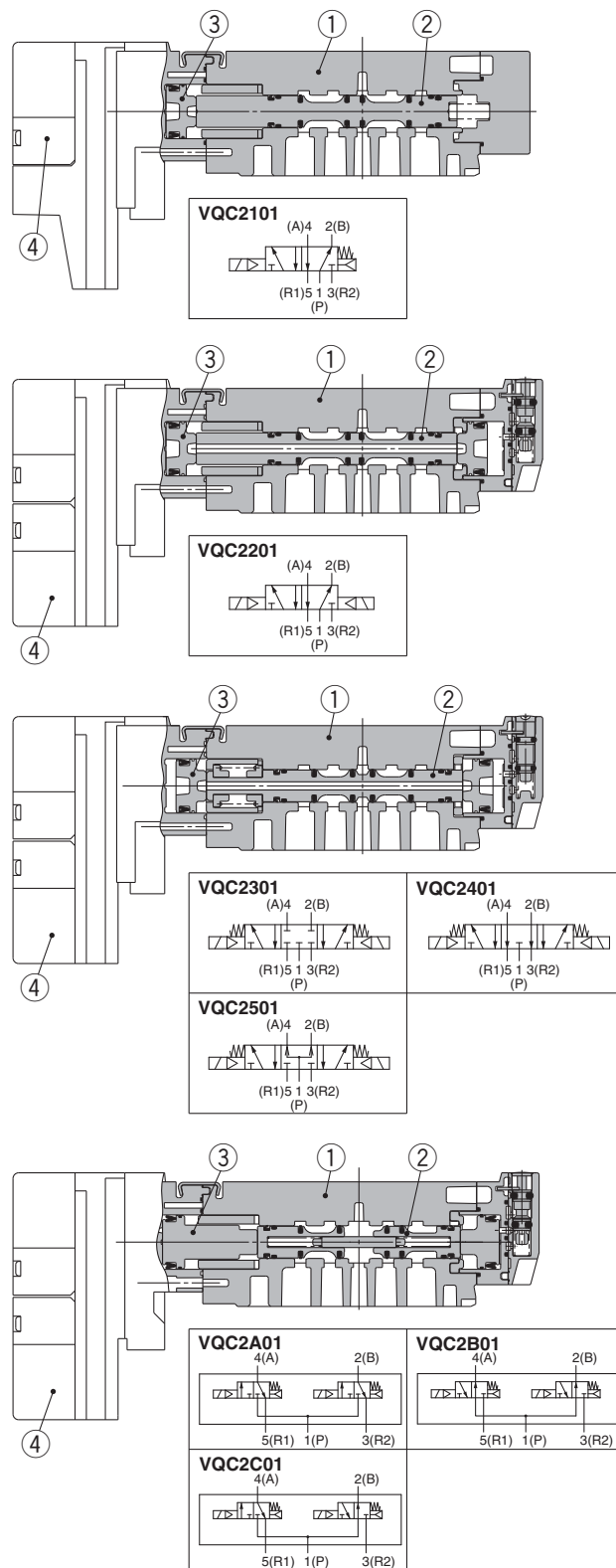

#### Component Parts

No.	Description	Material	Note
1	Body	Zinc die-casted	
2	Spool valve	Aluminum, HNBR	
3	Piston	Resin	
4	Pilot valve assembly	—	

Note) Refer to page 48 for "How to Order Pilot Valve Assembly."

# Series VQC1000/2000

## Exploded View of Manifold

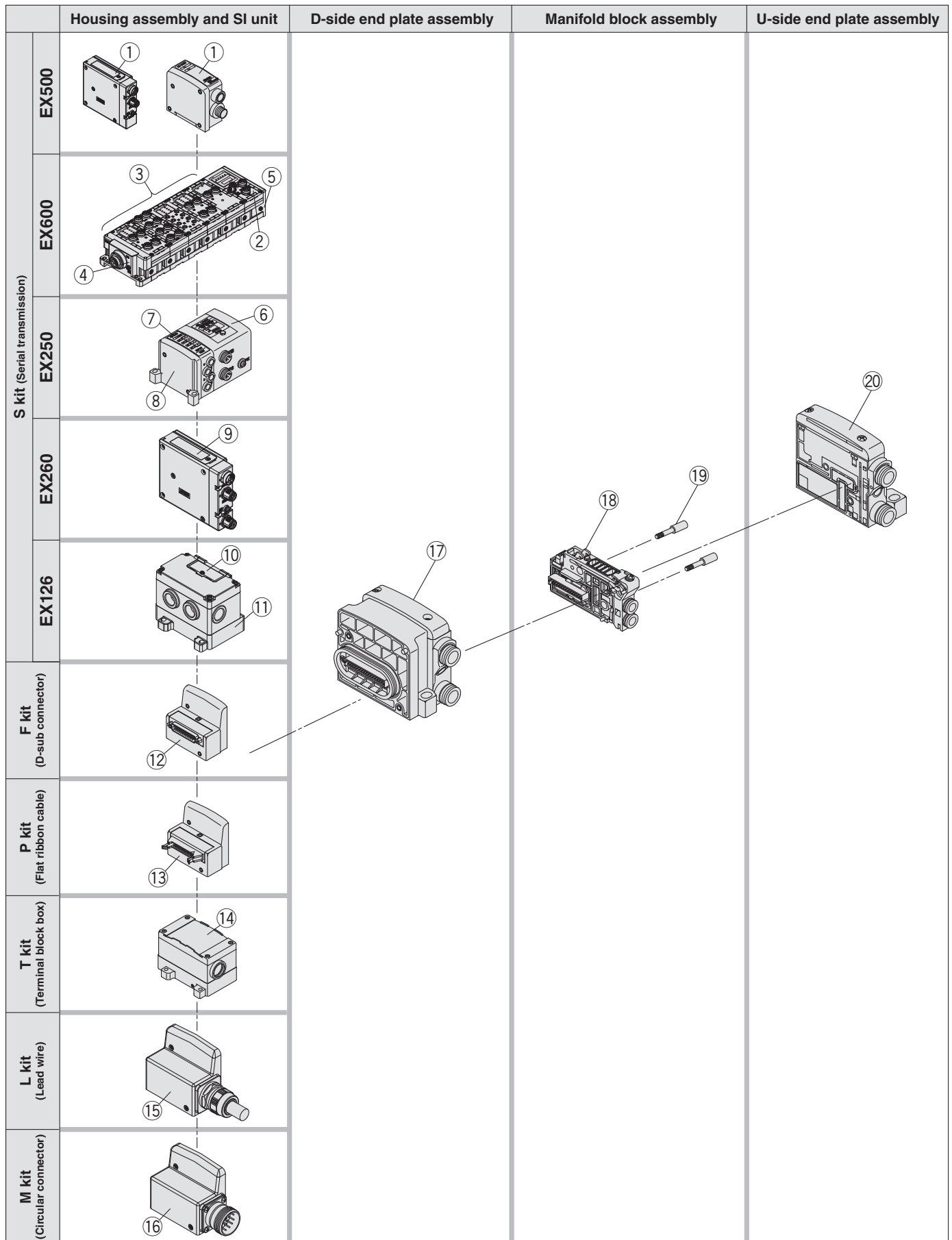



## Manifold Assembly Part No.

### Housing Assembly and SI Unit/Input Block

No.	Description	Part no.	Note	
①	SI unit	EX500-S103	EtherNet/IP™ PNP (Negative common)	
		EX500-Q001	DeviceNet™, PROFIBUS DP, EtherNet/IP™ NPN (Positive common)	
		EX500-Q101	DeviceNet™, PROFIBUS DP, EtherNet/IP™ PNP (Negative common)	
②	SI unit	EX600-SDN1A	DeviceNet™ PNP (Negative common)	
		EX600-SDN2A	DeviceNet™ NPN (Positive common)	
		EX600-SMJ1	CC-Link PNP (Negative common)	
		EX600-SMJ2	CC-Link NPN (Positive common)	
		EX600-SPR1A	PROFIBUS DP PNP (Negative common)	
		EX600-SPR2A	PROFIBUS DP NPN (Positive common)	
		EX600-SEN1	EtherNet/IP™ (1 port) PNP (Negative common)	
		EX600-SEN2	EtherNet/IP™ (1 port) NPN (Positive common)	
		EX600-SEN3	EtherNet/IP™ (2 port) PNP (Negative common)	
		EX600-SEN4	EtherNet/IP™ (2 port) NPN (Positive common)	
		EX600-SEC1	EtherCAT PNP (Negative common)	
		EX600-SEC2	EtherCAT NPN (Positive common)	
		EX600-SPN1	PROFINET PNP (Negative common)	
		EX600-SPN2	PROFINET NPN (Positive common)	
③	Digital input unit	EX600-DXNB	NPN input, M12 connector, 5 pins (4 pcs.), 8 inputs	
		EX600-DXPB	PNP input, M12 connector, 5 pins (4 pcs.), 8 inputs	
		EX600-DXNC	NPN input, M8 connector, 3 pins (8 pcs.), 8 inputs	
		EX600-DXNC1	NPN input, M8 connector, 3 pins (8 pcs.), 8 inputs, with open circuit detection	
		EX600-DXPC	PNP input, M8 connector, 3 pins (8 pcs.), 8 inputs	
		EX600-DXPC1	PNP input, M8 connector, 3 pins (8 pcs.), 8 inputs, with open circuit detection	
		EX600-DXND	NPN input, M12 connector, 5 pins (8 pcs.), 16 inputs	
		EX600-DXPD	PNP input, M12 connector, 5 pins (8 pcs.), 16 inputs	
		EX600-DXNE	NPN input, D-sub connector, 25 pins, 16 inputs	
		EX600-DXPE	PNP input, D-sub connector, 25 pins, 16 inputs	
		EX600-DXNF	NPN input, Spring type terminal box, 32 pins, 16 inputs	
		EX600-DXPF	PNP input, Spring type terminal box, 32 pins, 16 inputs	
	Digital output unit	EX600-DYNB	NPN output, M12 connector, 5 pins (4 pcs.), 8 outputs	
		EX600-DYPB	PNP output, M12 connector, 5 pins (4 pcs.), 8 outputs	
		EX600-DYNE	NPN output, D-sub connector, 25 pins, 16 outputs	
		EX600-DYPE	PNP output, D-sub connector, 25 pins, 16 outputs	
		EX600-DYNF	NPN output, Spring type terminal box, 32 pins, 16 outputs	
		EX600-DYPF	NPN output, Spring type terminal box, 32 pins, 16 outputs	
	Digital input/output unit	EX600-DMNE	NPN input/output, D-sub connector, 25 pins, 8 inputs/outputs	
		EX600-DMPE	PNP input/output, D-sub connector, 25 pins, 8 inputs/outputs	
		EX600-DMNF	NPN input/output, Spring type terminal box, 32 pins, 8 inputs/outputs	
		EX600-DMPF	PNP input/output, Spring type terminal box, 32 pins, 8 inputs/outputs	
	Analog input unit		EX600-AXA	M12 connector, 5 pins (2 pcs.), 2-channel input
	Analog output unit		EX600-AYA	M12 connector, 5 pins (2 pcs.), 2-channel output
	Analog input/output unit		EX600-AMB	M12 connector, 5 pins (4 pcs.), 2-channel inputs/outputs
	④	End plate	EX600-ED2	M12 connector, 5 pins, Max. supply current 2 A
			EX600-ED2-2	M12 connector, 5 pins, Max. supply current 2 A, with DIN rail mounting bracket
EX600-ED3			7/8 inch connector, 5 pins, Max. supply current 8 A	
EX600-ED3-2			7/8 inch connector, 5 pins, Max. supply current 8 A, with DIN rail mounting bracket	
⑤	Valve plate	EX600-ZMV1	Enclosed parts: round head screws (M4 x 6) 2 pcs., round head screws (M3 x 8) 4 pcs.	

# Series VQC1000/2000

## Manifold Assembly Part No.

### Housing Assembly and SI Unit/Input Block

No.	Description	Part no.	Note
⑥	SI unit	EX250-SPR1	PROFIBUS DP PNP (Negative common)
		EX250-SMJ2	CC-LinkNPN (Positive common)
		EX250-SAS3	AS-Interface, 8 in/8 out, 31 slave modes, 2 power supply systems PNP (Negative common)
		EX250-SAS5	AS-Interface, 4 in/4 out, 31 slave modes, 2 power supply systems PNP (Negative common)
		EX250-SAS7	AS-Interface, 8 in/8 out, 31 slave modes, 1 power supply system PNP (Negative common)
		EX250-SAS9	AS-Interface, 4 in/4 out, 31 slave modes, 1 power supply system PNP (Negative common)
		EX250-SCA1A	CANopen PNP (Negative common)
		EX250-SDN1	DeviceNet™ PNP (Negative common)
		EX250-SEN1	EtherNet/IP™ PNP (Negative common)
⑦	Input block	EX250-IE1	M12, 2 inputs
		EX250-IE2	M12, 4 inputs
		EX250-IE3	M8, 4 inputs
⑧	End plate assembly	EX250-EA1	Standard
		EX250-EA2	For DIN rail mounting
⑨	SI unit	EX260-SDN1	DeviceNet™, M12 connector, 32 pins PNP (Negative common)
		EX260-SDN2	DeviceNet™, M12 connector, 32 pins NPN (Positive common)
		EX260-SDN3	DeviceNet™, M12 connector, 16 pins PNP (Negative common)
		EX260-SDN4	DeviceNet™, M12 connector, 16 pins NPN (Positive common)
		EX260-SPR1	PROFIBUS DP, M12 connector, 32 pins PNP (Negative common)
		EX260-SPR2	PROFIBUS DP, M12 connector, 32 pins NPN (Positive common)
		EX260-SPR3	PROFIBUS DP, M12 connector, 16 pins PNP (Negative common)
		EX260-SPR4	PROFIBUS DP, M12 connector, 16 pins NPN (Positive common)
		EX260-SPR5	PROFIBUS DP, D-sub connector, 32 pins PNP (Negative common)
		EX260-SPR6	PROFIBUS DP, D-sub connector, 32 pins NPN (Positive common)
		EX260-SPR7	PROFIBUS DP, D-sub connector, 16 pins PNP (Negative common)
		EX260-SPR8	PROFIBUS DP, D-sub connector, 16 pins NPN (Positive common)
		EX260-SMJ1	CC-Link, M12 connector, 32 pins PNP (Negative common)
		EX260-SMJ2	CC-Link, M12 connector, 32 pins NPN (Positive common)
		EX260-SMJ3	CC-Link, M12 connector, 16 pins PNP (Negative common)
		EX260-SMJ4	CC-Link, M12 connector, 16 pins NPN (Positive common)
		EX260-SEC1	EtherCAT, M12 connector, 32 pins PNP (Negative common)
		EX260-SEC2	EtherCAT, M12 connector, 32 pins NPN (Positive common)
		EX260-SEC3	EtherCAT, M12 connector, 16 pins PNP (Negative common)
		EX260-SEC4	EtherCAT, M12 connector, 16 pins NPN (Positive common)
		EX260-SPN1	PROFINET, M12 connector, 32 pins PNP (Negative common)
		EX260-SPN2	PROFINET, M12 connector, 32 pins NPN (Positive common)
		EX260-SPN3	PROFINET, M12 connector, 16 pins PNP (Negative common)
		EX260-SPN4	PROFINET, M12 connector, 16 pins NPN (Positive common)
EX260-SEN1	EtherNet/IP™, M12 connector, 32 pins PNP (Negative common)		
EX260-SEN2	EtherNet/IP™, M12 connector, 32 pins NPN (Positive common)		
EX260-SEN3	EtherNet/IP™, M12 connector, 16 pins PNP (Negative common)		
EX260-SEN4	EtherNet/IP™, M12 connector, 16 pins NPN (Positive common)		
⑩	SI unit	EX126D-SMJ1	CC-Link NPN (Positive common)
⑪	Terminal block plate	VVQC1000-74A-2	For EX126 SI unit mounting
⑫	D-sub connector housing assembly	VVQC1000-F25-1	F kit, 25 pins
⑬	Flat ribbon cable housing assembly	VVQC1000-P26-1	P kit, 26 pins
		VVQC1000-P20-1	P kit, 20 pins
⑭	Terminal block box housing assembly	VVQC1000-T0-1	T kit
⑮	Lead wire housing assembly	VVQC1000-L25-0-1	L kit with 0.6 m lead wire
		VVQC1000-L25-1-1	L kit with 1.5 m lead wire
		VVQC1000-L25-2-1	L kit with 3.0 m lead wire
⑯	Circular connector housing assembly	VVQC1000-M26-1	M kit, 26 pins

**Manifold Assembly Part No.**

**<D-Side End Plate Assembly>**

⑰ D-side end plate assembly part no.

VVQC **1** 000-3A-1-□-□

Series

1	VQC1000
2	VQC2000

Port size

Symbol	VQC1000	VQC2000
C8	●	
C10		●
N9	●	
N11		●

Option

—	Common EXH
R	External pilot
S	Direct EXH outlet with built-in silencer

**<U-Side End Plate Assembly>**

⑳ U-side end plate assembly part no.

VVQC **1** 000-2A-**1**-C8-□

Series

1	VQC1000
2	VQC2000

Supply/Exhaust port entry direction

1	Cylinder port side
2 (Note)	Branch type

Note) VQC2000 only

Port size

Symbol	VQC1000	VQC2000
C8	●	
C10		●
C12		●
N9	●	
N11		●
N13		●

Option

—	Common EXH
R	External pilot
S	Direct EXH outlet with built-in silencer

**<Manifold Block Assembly>**

⑱ Manifold block assembly part no.

VVQC **1** 000-1A-D-C6-□

Series

1	VQC1000
2	VQC2000

Note) Tie-rods (2 pcs.) for additional stations included.

Wiring specifications

D	Double wiring
S	Single wiring

Port size

Symbol	Port size	VQC1000	VQC2000
C3	For ø3.2 One-touch fitting	●	
C4	For ø4 One-touch fitting	●	●
C6	For ø6	●	●
C8	For ø8		●
N1	For ø1/8"	●	
N3	For ø5/32"	●	●
N7	For ø1/4"	●	●
N9	For ø5/16"		●
M5	For M5 thread	●	

Option

—	None
B	With back pressure check valve

**<Replacement Parts>**

Pilot valve assembly

V112 □ - **5** A

Coil voltage

5	24 VDC
6	12 VDC

Function

—	Standard (0.4 W)
B	High-speed response type (0.95 W)
K	High-pressure type (1.0 MPa, 0.95 W)

Note 1) Common to single solenoid and double solenoid  
 Note 2) The voltage (including light/surge voltage suppressor), positive common and negative common cannot be changed by changing the pilot valve assembly.

⑲ Tie-rod assembly part no. (2 pcs.)

VQC1000	VVQC1000-TR-□
VQC2000	VVQC2000-TR-□

Note 1) Please order when reducing the number of manifold stations. When increasing the number of stations, additional orders are not required since they are included in the manifold block assembly.  
 Note 2) □: Stations 02 to 24

# Series VQC1000

## VQC1000: Manifold Optional Parts

### Blanking plate assembly VVQ1000-10A-1



It is used by attaching on the manifold block for being prepared for removing a valve for maintenance reasons or planning to mount a spare valve, etc.

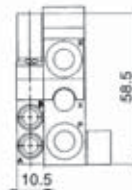
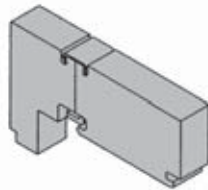

### Individual SUP spacer VVQ1000-P-1-C<sub>6</sub>-N<sub>7</sub>

When the same manifold is to be used for different pressures, individual SUP spacers are used as SUP ports for different pressures. (One station space is occupied.)

Block both sides of the station, for which the supply pressure from the individual SUP spacer is used, with SUP block plates. (Refer to the application example.)

\* Specify the spacer mounting position and SUP block plate position by means of the manifold specification sheet.

The block plate is used in one or two places for one set. (Two SUP block plates for blocking SUP passage are attached to the individual SUP spacer.)

\* As a standard, electric wiring is connected to the position of the manifold station where the individual SUP spacer is mounted.

\* If wiring is not required for stations equipped with spacers, enter "X" in the special wiring specifications column in the manifold specification sheet.

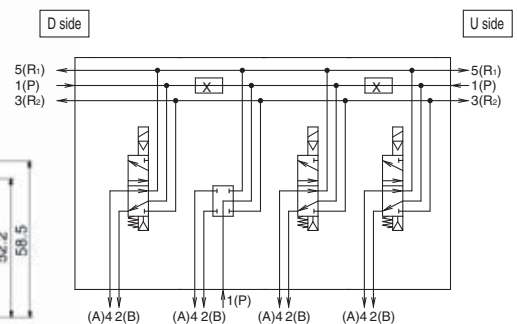
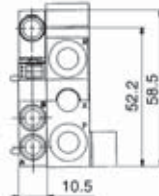
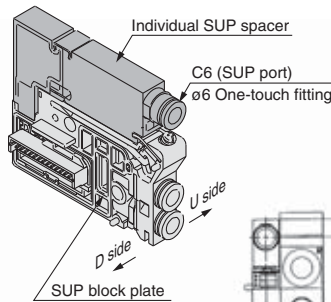

### Individual EXH spacer VVQ1000-R-1-C<sub>6</sub>-N<sub>7</sub>

When valve exhaust affects other stations due to the circuit configuration, this spacer is used for individual valve exhaust. (One station space is occupied.)

Block both sides of the individual valve EXH station. (Refer to the application example.)

\* Specify the spacer mounting position, as well as the EXH passage blocking position by means of the manifold specification sheet. The block plate is used in one or two places for one set.

\* An EXH block base assembly is used in the blocking position when ordering an EXH spacer incorporated with a manifold. However, do not order an EXH block base assembly because it is attached to the spacer.

When separately ordering an individual EXH spacer, separately order an EXH block base assembly because it is not attached to the spacer.

\* As a standard, electric wiring is connected to the position of the manifold station where the individual EXH spacer is mounted.

\* If wiring is not required for stations equipped with spacers, enter "X" in the special wiring specifications column in the manifold specification sheet.

\* Do not install any back pressure check valve on the manifold station, on which the spacer is to be mounted. When installing the back pressure check valve on other manifold station, be sure to specify the manifold station position on the manifold specification sheet instead of ordering by specifying the manifold option symbol "B".

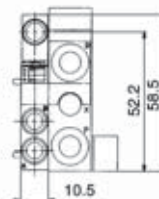
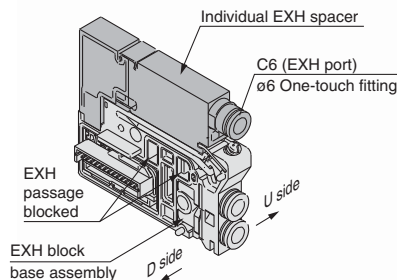

Description/Model	Stations						
	1	2	3	4	5	6	7
Valve	Single	●	●	●			
Option	Individual EXH spacer VVQ1000-R-1-C6		●				
	EXH blocking position: Specify 2 places.	●		●			

Individual EXH spacer + EXH block base assembly      Valve + EXH block base assembly

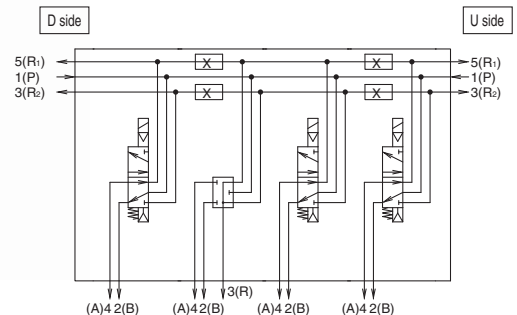

### SUP block plate VVQ1000-16A

When different pressures are supplied to a manifold, a SUP block plate is used to block the stations under different pressures.

\* Specify the mounting position by means of the manifold specification sheet.

#### <Block indication label>

Indication labels to confirm the blocking position are attached (Each for SUP passage and SUP/EXH passage blocking positions).

\* When ordering a block plate incorporated with a manifold, a block indication label is attached to the manifold.

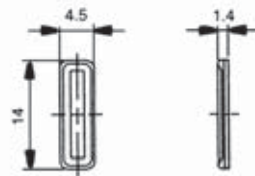
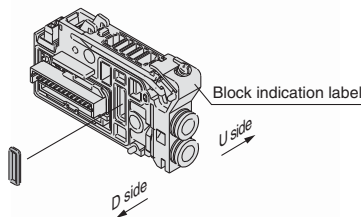

SUP passage blocked

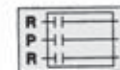

SUP/EXH passage blocked

**Blanking plate with connector**

VVQ1000-1C-□

Connector

—	Without connector
1	With connector/2-wire
2	With connector/4-wire

Connector lead wire length (mm)

—	300	20	2000
6	600	25	2500
10	1000	30	3000
15	1500		



Connector on the power supply side is not attached.

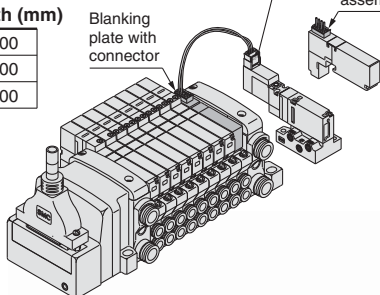

**Connector assembly part no.**

AXT661-43 A-6

43	4-wire
44	2-wire

Lead wire length (mm)

—	300
6	600
10	1000
20	2000
30	3000

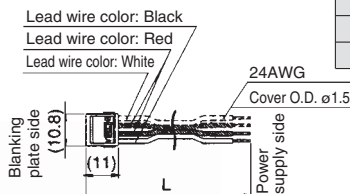

Blanking plate with a connector for individually outputting electricity to drive a single valve or equipment that are not on the manifold base.  
 \* When "N" is suffixed to the end of the name plate, the plate will be different from a standard shape.  
 Note) Electric current should be 1A or less (including the mounted valves).

**EXH block base assembly**

VVQC1000-19A-□-(C3/C4/C6/M5/N1/N3/N7)

Wiring specifications

S	Single wiring
D	Double wiring

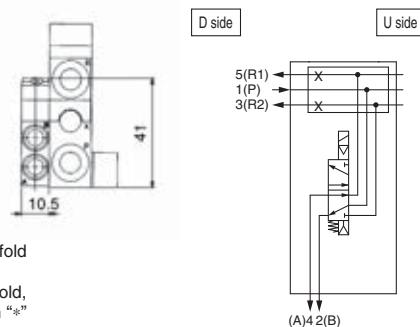
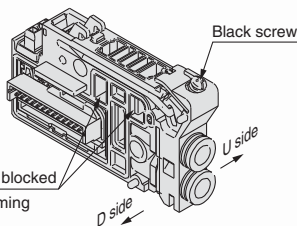

The manifold block assembly is used between stations for which exhaust is desired to be divided when valve exhaust affects other stations due to the circuit configuration. The EXH passage on the D-side is blocked in the EXH block base assembly. It is also used in combination with an individual EXH spacer for individual exhaust.

**<Block indication label>**

Indication labels to confirm the blocking position are attached (Each for EXH passage and SUP/EXH passage blocking positions).  
 \* When ordering this option incorporated with a manifold, a block indication label is attached to the manifold.

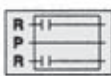

EXH passage blocked



SUP/EXH passage blocked

\*Specify the mounting position by means of the manifold specification sheet.  
 \*When ordering this option incorporated with a manifold, specify the EXH block base assembly part number with "\*" in front of it beneath the manifold part number.

**Back pressure check valve assembly [-B]**

VVQ1000-18A

It prevents cylinder from malfunctioning by other valve's exhaust entry. Insert it into R (EXH) port on the manifold side of a valve which is affected. It is effective when a single-acting cylinder is used or an exhaust center type solenoid valve is used.  
 \* When ordering it being mounted on all manifold stations, suffix "-B" to the end of the manifold part number.  
 Note) When a back pressure check valve is desired, and is to be installed only in certain manifold stations, clearly indicate the part number and specify the mounting station by means of the manifold specification sheet.

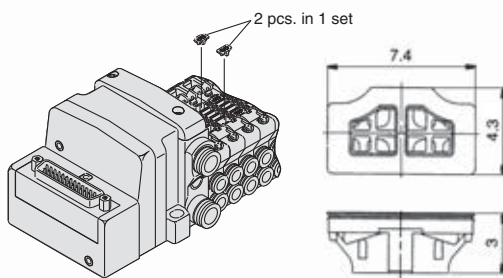

**(Precautions)**

- The manifold installed type back pressure check valve assembly is assembly parts with a check valve structure. However, since slight air leakage against the back pressure is allowed due to its structure, adverse effects of the back pressure due to increase in exhaust resistance cannot be prevented if the manifold exhaust port and other exhaust ports are put together for piping or if the piping diameter is narrowed. As a result, this may cause the actuator and air operated equipment to malfunction. So, be careful not to restrict the exhaust air.
- When a back pressure check valve is mounted, the effective area of the valve will decrease by about 20%.

**Name plate [-N]**

VVQ1000-<sup>N</sup>NC-Station (1 to Max. stations) (-X4)

N: Standard  
 NC: For mounting blanking plate with connector

-X4: For mounting slide locking type manual valve

It is a transparent resin plate for placing a label that indicates solenoid valve function, etc. Insert it into the groove on the side of the end plate and bend it as shown in the figure.  
 \* When the blanking plate with connector is mounted, it automatically will be "VVQ1000-NC-n"  
 \* When the slide locking type manual valve is mounted, it automatically will be "VVQ1000-N-n-X4"  
 \* When ordering this option incorporated with a manifold, suffix "-N" to the end of the manifold part number.

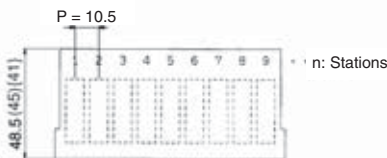
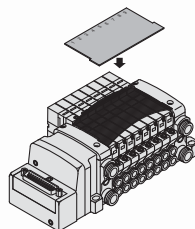

Note) ( ) : VVQ1000-NC-n  
 Note) { } : VVQ1000-N-n-X4

**Blanking plug (For One-touch fittings)**

KQ2P-□

It is inserted into an unused cylinder port and SUP/EXH ports. Purchasing order is available in units of 10 pieces.

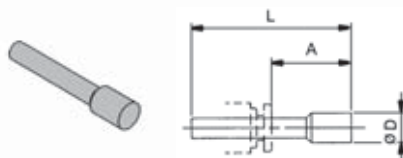

**Dimensions**

Applicable fitting size ød	Model	A	L	D	Applicable fitting size ød	Model	A	L	D
3.2	KQ2P-23	16	31.5	5	1/8"	KQ2P-01	16	31.5	5
4	KQ2P-04	16	32	6	5/32"	KQ2P-03	16	32	6
6	KQ2P-06	18	35	8	1/4"	KQ2P-07	18	35	8.5
8	KQ2P-08	20.5	39	10	5/16"	KQ2P-09	20.5	39	10



# Series VQC1000

## VQC1000: Manifold Optional Parts

### Port plug VVQ0000-58A

The plug is used to block the cylinder port.

\* When ordering this option incorporated with a manifold, indicate "CM" for the port size of the manifold part number, as well as, the mounting position and number of stations and cylinder port mounting positions, 4(A) and 2(B) by means of the manifold specification sheet.

\* Gently screw an M3 screw in the port plug hole and pull it for removal.

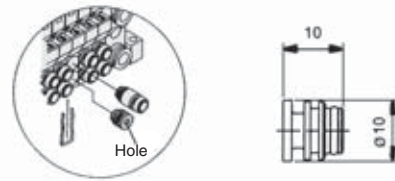

### Elbow fitting assembly

#### VVQ1000-F-L(C3/C4/C6/M5/N1/N3/N7)

It is used for piping that extends upward or downward from the manifold.

\* When ordering this option incorporated with a manifold, indicate "L□" or "B□" for the manifold port size (when installed in all stations.)

When installing it in part of the manifold stations, specify the elbow fitting assembly part number and the mounting position and number of stations by means of the manifold specification sheet.

\* When mounting elbow fitting assembly on the edge of manifold station and a silencer on EXH port, select a silencer, AN15-C08.

A silencer (AN200-KM8) is interfered with fittings.

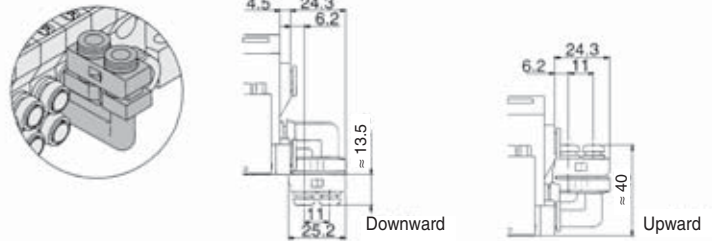

### DIN rail mounting bracket [-D]

#### VVQ1000-57A

{For F/L/M/P/S (EX500) kit}

#### VVQ1000-57A-S

{For S (EX250) kit}

#### VVQ1000-57A-T (For T kit)

It is used for mounting a manifold on a DIN rail.

\* When ordering this option incorporated with a manifold, suffix "-D" to the end of the manifold part number.

1 set of DIN rail mounting bracket is used for 1 manifold (2 DIN rail mounting brackets).

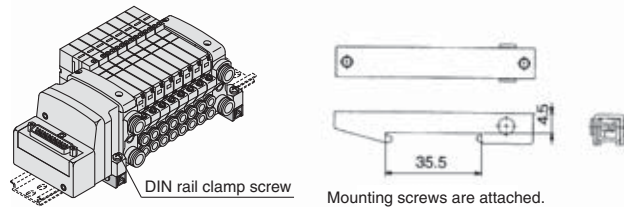

### Direct EXH outlet with built-in silencer [-S]

This is a type with an exhaust outlet atop the manifold end plate. The built-in silencer exhibits an excellent noise suppression effect. (Noise reduction: 30 dB)

\* When ordering this option incorporated with a manifold, suffix "-S" to the end of the manifold part number.

Note) A large quantity of drainage generated in the air source results in exhaust of air together with drainage.

● Refer to page 58 for maintenance.

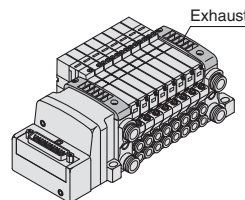

### Dual flow fitting assembly

#### VVQ1000-52A-C8 N9

This is a fitting to multiply the flow rate by combining the outputs of 2-valve stations. It is used for driving a large bore cylinder. This is a One-touch fitting for a port size of ø8 or ø5/16".

\* The port size of the manifold part number is "MM".

Clearly indicate the dual flow fitting assembly part number and specify the mounting positions by means of the manifold specification sheet.

\* In dual flow fitting assembly, a special clip which is combined in one-piece of 2 stations is attached as a holding clip.

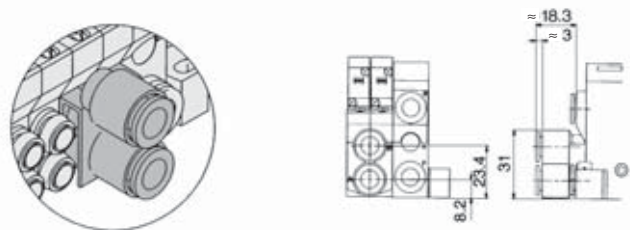

### Silencer (For EXH port)

This silencer is to be inserted into the EXH port (One-touch fittings) of the common exhaust type.

\* When mounting elbow fitting assembly (VVQ1000-F-L□) on the edge of manifold station, select a silencer, AN15-C08. A silencer (AN200-KM8) is interfered with fittings.

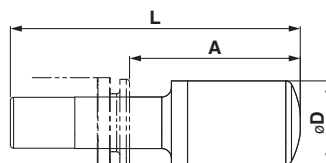

#### Dimensions

Series	Applicable fitting size ød	Model	A	L	D	Effective area (mm <sup>2</sup> )	Noise reduction (dB)
VQC1000	8	AN15-C08	26.5	45	13	20	30

### Double check block (Separated) for VQC1000 VQ1000-FPG-□□-□

It is used on the outlet side piping to keep the cylinder in the intermediate position for long periods of time. Combining the double check block with a built-in pilot type double check valve and a 3-position exhaust center solenoid valve will enable the cylinder to stop in the middle or maintain its position for a long time. The combination with a 2-position single/double solenoid valve will permit this block to be used for preventing the dropping at the cylinder stroke end when the SUP residual pressure is released.

#### Specifications

Max. operating pressure	0.8 MPa
Min. operating pressure	0.15 MPa
Ambient and fluid temp.	-5 to 50°C
Flow characteristics: C	0.60 dm <sup>3</sup> /(s·bar)
Max. operating frequency	180 c.p.m

Note) Based on JIS B 8375-1981  
(Supply pressure: 0.5 MPa)

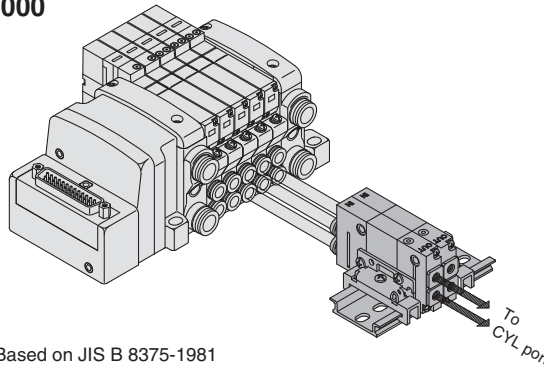

#### <Circuit diagram>

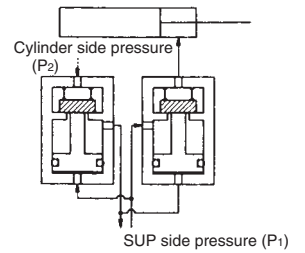

VVQ1000-FPG-02 1 set  
\* VQ1000-FPG-C6M5-D 2 pcs.

## Dimensions

### Single unit

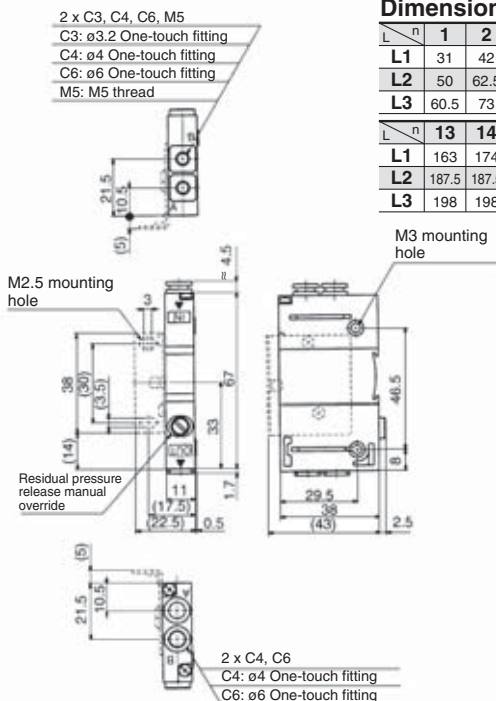

### Dimensions

Formula L1 = 11n + 20 n: Station (Maximum 24)

n	1	2	3	4	5	6	7	8	9	10	11	12
L1	31	42	53	64	75	86	97	108	119	130	141	152
L2	50	62.5	75	87.5	100	112.5	125	137.5	150	162.5	175	187.5
L3	60.5	73	85.5	98	110.5	123	135.5	148	160.5	173	185.5	198

n	13	14	15	16	17	18	19	20	21	22	23	24
L1	163	174	185	196	207	218	229	240	251	262	273	284
L2	187.5	187.5	200	212.5	225	237.5	250	262.5	275	287.5	300	310.5
L3	198	198	210.5	223	235.5	248	260.5	273	285.5	298	310.5	310.5

### Manifold

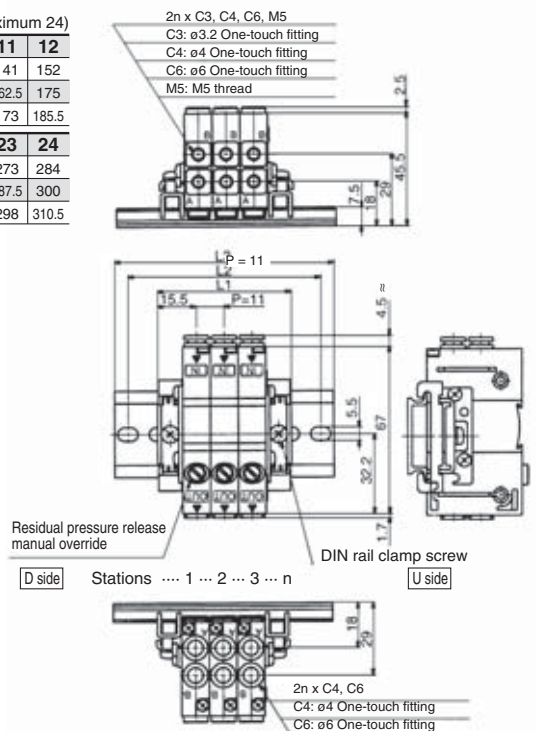

## How to Order

### Double check block

VQ1000-FPG-**C4** **M5** - **F**

#### IN side port size

<b>M5</b>	M5 thread
<b>C3</b>	ø3.2 One-touch fitting
<b>C4</b>	ø4 One-touch fitting
<b>C6</b>	ø6 One-touch fitting
<b>N3</b>	ø5/32" One-touch fitting
<b>N7</b>	ø1/4" One-touch fitting

#### OUT side port size

<b>M5</b>	M5 thread
<b>C3</b>	ø3.2 One-touch fitting
<b>C4</b>	ø4 One-touch fitting
<b>C6</b>	ø6 One-touch fitting
<b>N3</b>	ø5/32" One-touch fitting
<b>N7</b>	ø1/4" One-touch fitting

#### Option

-	None
<b>F</b>	With bracket
<b>D</b>	DIN rail mounting (For manifold)
<b>N</b>	Name plate

Note) When two or more symbols are specified, indicate them alphabetically. Example) -DN

### Manifold (DIN rail mounting)

VVQ1000-FPG-**06**

#### Stations

<b>01</b>	1 station
⋮	⋮
<b>16</b>	16 stations

When ordering a double check block, order the DIN rail mounting [-D].

#### <Ordering example>

VVQ1000-FPG-06-6-station manifold

\*VQ1000-FPG-C4M5-D, 3 sets } Double check block  
\*VQ1000-FPG-C6M5-D, 3 sets }

#### Bracket Assembly

Part no.	Tightening torque
VQ1000-FPG-FB	0.22 to 0.25 N·m

#### <Example>

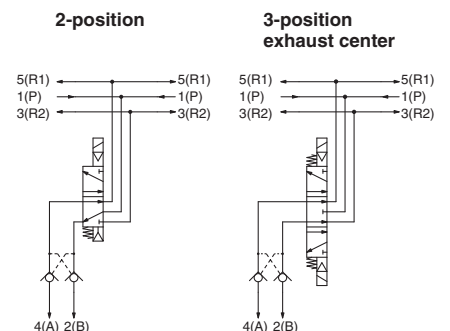

## Caution

- Air leakage from the pipe between the valve and cylinder or from the fittings will prevent the cylinder from stopping for long periods of time. Check the leakage using neutral household detergent, such as dish washing soap. Also, check the cylinder's tube gasket, piston packing and rod packing for air leakage.
- Since One-touch fittings allow slight air leakage, screw piping (with M5 thread) is recommended when stopping the cylinder in the middle for long periods of time.
- Combining double check block with 3-position closed center or pressure center solenoid valve will not work.
- M5 fitting assembly is attached, not incorporated into the double check block. After screwing in the M5 fittings, mount the assembly on the double check block. (Tightening torque: 0.8 to 1.2 N·m)
- If the exhaust of the double check block is restricted too much, the cylinder may not operate properly and may not stop intermediately.
- Set the cylinder load so that the cylinder pressure will be within two times that of the supply pressure.

# Series VQC2000

## VQC2000: Manifold Optional Parts

### Blanking plate assembly VVQ2000-10A-1

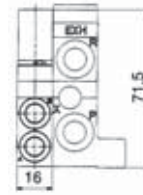
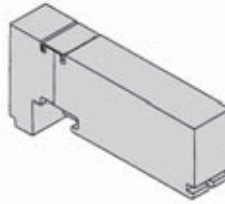

It is used by attaching on the manifold block for being prepared for removing a valve for maintenance reasons or planning to mount a spare valve, etc.

### Individual SUP spacer VVQ2000-P-1-C<sub>8</sub> N<sub>9</sub>

When the same manifold is to be used for different pressures, individual SUP spacers are used as SUP ports for different pressures. (One station space is occupied.) Block both sides of the station, for which the supply pressure from the individual SUP spacer is used, with SUP block plates. (Refer to the application example.)

\* Specify the spacer mounting position and SUP passage blocking position by means of the manifold specification sheet. The block plate is used in one or two places for one set. (Two SUP block plates for blocking SUP passage are attached to the individual SUP spacer.)

\* As a standard, electric wiring is connected to the position of the manifold station where the individual SUP spacer is mounted.  
\* If wiring is not required for stations equipped with spacers, enter "X" in the special wiring specifications column in the manifold specification sheet.

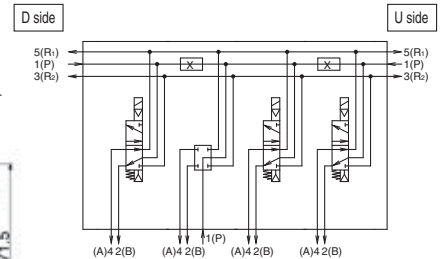
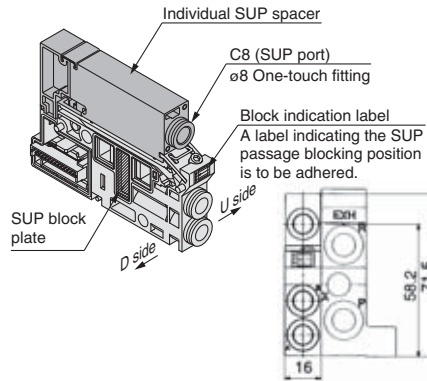

### Individual EXH spacer VVQ2000-R-1-C<sub>8</sub> N<sub>9</sub>

When valve exhaust affects other stations due to the circuit configuration, this spacer is used for individual valve exhaust. (One station space is occupied.) Block both sides of the individual valve EXH station. (Refer to the application example.)

\* Specify the spacer mounting position, as well as the EXH passage blocking position by means of the manifold specification sheet. The block plate is used in one or two places for one set. (Four EXH block plates (2 sets) for blocking EXH passage are attached to the individual EXH spacer.)

\* As a standard, electric wiring is connected to the position of the manifold station where the individual EXH spacer is mounted.

\* If wiring is not required for stations equipped with spacers, enter "X" in the special wiring specifications column in the manifold specification sheet.

\* Do not install any back pressure check valve on the manifold station, on which the spacer is to be mounted. When installing the back pressure check valve on other manifold station, be sure to specify the manifold station position on the manifold specification sheet instead of ordering by specifying the manifold option symbol "B".

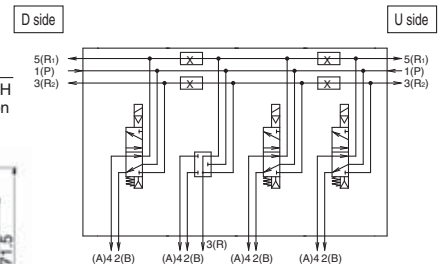
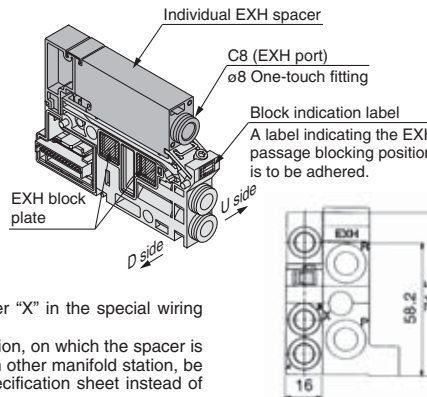

### SUP block plate VVQ2000-16A

When different pressures are supplied to a manifold, a SUP block plate is used to block the stations under different pressures.

\* Specify the mounting position by means of the manifold specification sheet.

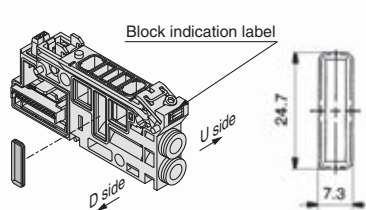

#### <Block indication label>

Indication labels to confirm the blocking position are attached. (Each for SUP passage and SUP/EXH passage blocking positions)



SUP passage blocked SUP/EXH passage blocked

\* When ordering a block plate incorporated with a manifold, a block indication label is attached to the manifold.

### EXH block plate VVQ2000-19A

The EXH block plate is used between stations for which exhaust is desired to be divided when valve exhaust affects other stations configuration. It is also used in combination with an individual EXH spacer for individual exhaust.

\* Specify the mounting position by means of the manifold specification sheet.

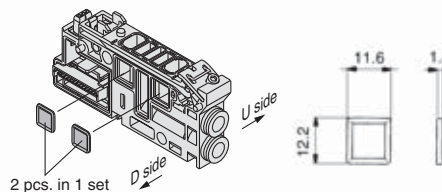

#### <Block indication label>

Indication labels to confirm the blocking position are attached. (Each for EXH passage and SUP/EXH passage blocking positions)

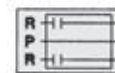

EXH passage blocked SUP/EXH passage blocked

\* When ordering a block plate incorporated with a manifold, a block indication label is attached to the manifold.

### Back pressure check valve assembly [-B] VVQ2000-18A

It prevents cylinder malfunction caused by other valve exhaust entry. Insert it into R (EXH) port on the manifold side of a valve which is affected. It is effective when a single-acting cylinder is used or an exhaust center type solenoid valve is used.

\* When ordering this option incorporated with a manifold, suffix "-B" to the end of the manifold part number.

Note) When a back pressure check valve is desired, and is to be installed only in certain manifold stations, clearly indicate the part number and specify the mounting position by means of the manifold specification sheet.

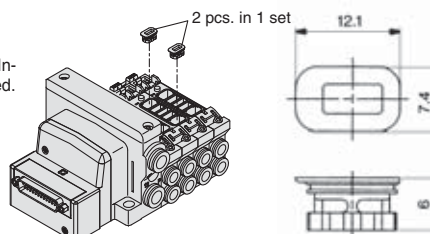

#### <Precautions>

1. The manifold installed type back pressure check valve assembly is assembly parts with a check valve structure. However, since slight air leakage against the back pressure is allowed due to its structure, adverse effects of the back pressure due to increase in exhaust resistance cannot be prevented if the manifold exhaust port and other exhaust ports are put together for piping or if the piping diameter is narrowed. As a result, this may cause the actuator and air operated equipment to malfunction. So, be careful not to restrict the exhaust air.
2. When a back pressure check valve is mounted, the effective area of the valve will decrease by about 20%.



**Name plate [-N]**

**VVQ2000-N-Station (1 to Max. stations) (-X4)**

-X4: For mounting slide locking type manual valve

It is a transparent resin plate for placing a label that indicates solenoid valve function, etc. Insert it into the groove on the side of the end plate and bend it as shown in the figure.  
 \* When the slide locking type manual valve is mounted, it automatically will be "VVQ2000-N-n-X4"  
 \* When ordering this option incorporated with a manifold, suffix "-N" to the end of the manifold part number.

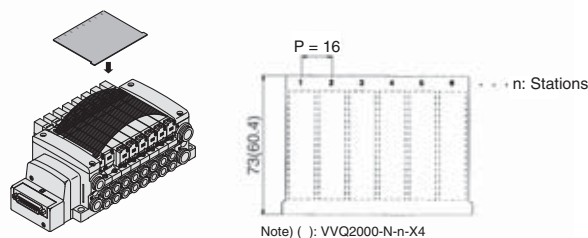

Note ( ) : VVQ2000-N-n-X4

**Blanking plug (For One-touch fittings)**

**KQ2P-□**

It is inserted into an unused cylinder port and SUP/EXH ports. Purchasing order is available in units of 10 pieces.

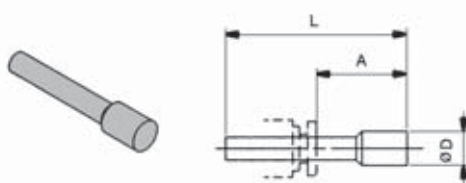

**Dimensions**

Applicable fitting size $\phi d$	Model	A	L	D
4	KQ2P-04	16	32	6
6	KQ2P-06	18	35	8
8	KQ2P-08	20.5	39	10
10	KQ2P-10	22	43	12
5/32"	KQ2P-03	16	32	6
1/4"	KQ2P-07	18	35	8.5
5/16"	KQ2P-09	20.5	39	10
3/8"	KQ2P-11	22	43	11.5

**Port plug**

**VVQ1000-58A**

The plug is used to block the cylinder port.  
 \* When ordering this option incorporated with a manifold, indicate "CM" for the port size of the manifold part number, as well as, the mounting station and cylinder port mounting positions, A and B, by means of the manifold specification sheet.

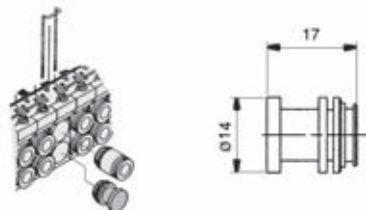

**DIN rail mounting bracket [-D]**

**VVQC2000-57A**

{For F/L/M/P/S (EX500) kit}

**VVQC2000-57A-S**

{For S (EX250) kit}

**VVQC2000-57A-T (For T kit)**

It is used for mounting a manifold on a DIN rail.  
 \* When ordering this option incorporated with a manifold, suffix "-D" to the end of the manifold part number.  
 1 set of DIN rail mounting bracket is used for 1 manifold (2 DIN rail mounting brackets).

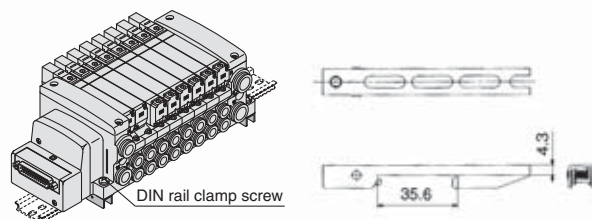

**Direct EXH outlet with built-in silencer [-S]**

This is a type with an exhaust outlet atop the manifold end plate. The built-in silencer exhibits an excellent noise suppression effect. (Noise reduction: 30 dB)  
 \* When ordering this option incorporated with a manifold, suffix "-S" to the end of the manifold part number.

Note) A large quantity of drainage generated in the air source results in exhaust of air together with drainage.

● Refer to page 58 for maintenance.

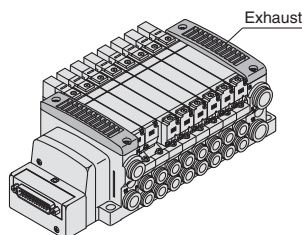

**Silencer (For EXH port)**

This silencer is to be inserted into the EXH port (One-touch fittings).

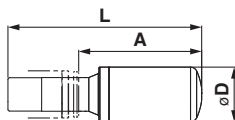

**Dimensions**

Series	Applicable fitting size $\phi d$	Model	A	L	D	Effective area (mm <sup>2</sup> ) (Cv factor)	Noise reduction (dB)
VQC2000	10	AN20-C10	36.5	57.5	16.5	30	30

**Elbow fitting assembly**

**VVQ2000-F-L(C4/C6/C8/N3/N7/N9)**

It is used for piping that extends upward or downward from the manifold.  
 When installing it only in some manifold stations, specify the elbow fitting assembly part number and the mounting position by means of the manifold specification sheet.

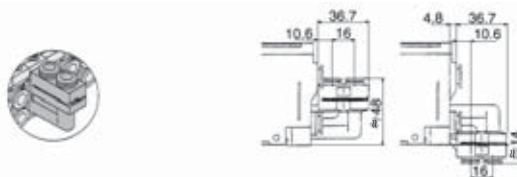

**Dual flow fitting assembly**

**VVQ2000-52A-C10**

N11

This is a fitting to multiply the flow rate by combining the outputs of 2-valve stations. It is used for driving a large bore cylinder. This is a One-touch fitting for a port size of  $\phi 10$  or  $\phi 3/8$ ".

\* The port size of the manifold part number is "MM".  
 Clearly indicate the dual flow fitting assembly part number and specify the mounting position by means of the manifold specifications.

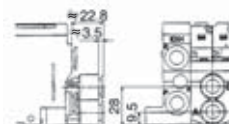

# Series VQC2000

## Double check block (Separated) for VQC2000

VQ2000-FPG-□□-□

It is mounted on the outlet side piping to keep the cylinder in the intermediate position for long periods of time. Combining with a 3-position exhaust centre solenoid valve will enable the cylinder to stop in the middle or maintain its position for a long time. Combining with a 2-position single/double solenoid valve will prevent a cylinder from dropping at the stroke end when the residual pressure of SUP is released.

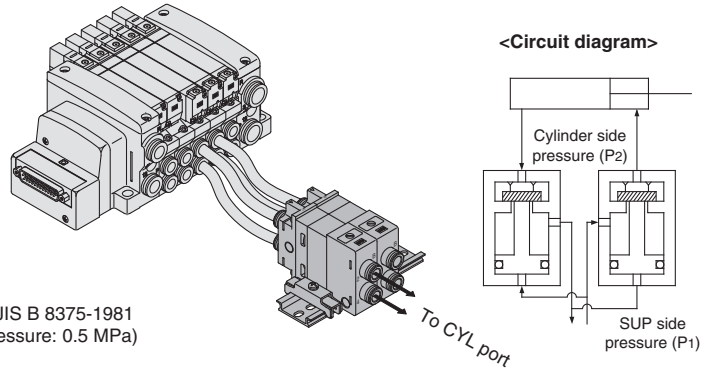

## Specifications

Max. operating pressure	0.8 MPa
Min. operating pressure	0.15 MPa
Ambient and fluid temp.	-5 to 50°C
Flow characteristics: C	3.0 dm <sup>3</sup> /(s·bar)
Max. operating frequency	180 c.p.m

Note) Based on JIS B 8375-1981 (Supply pressure: 0.5 MPa)

## Dimensions

### Single unit

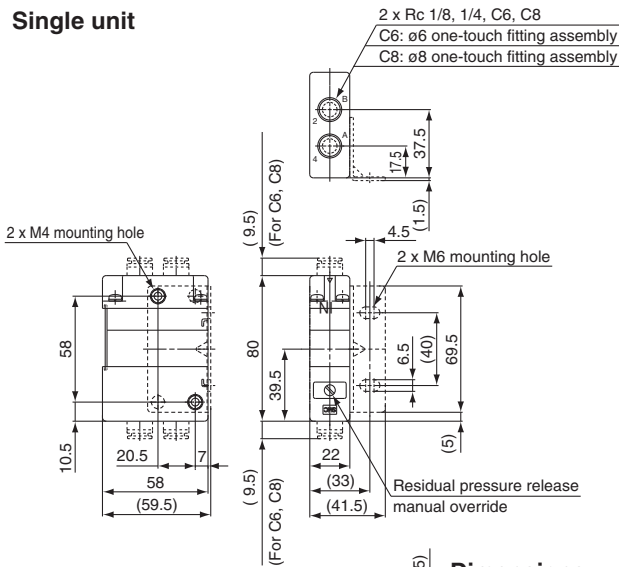

### Manifold

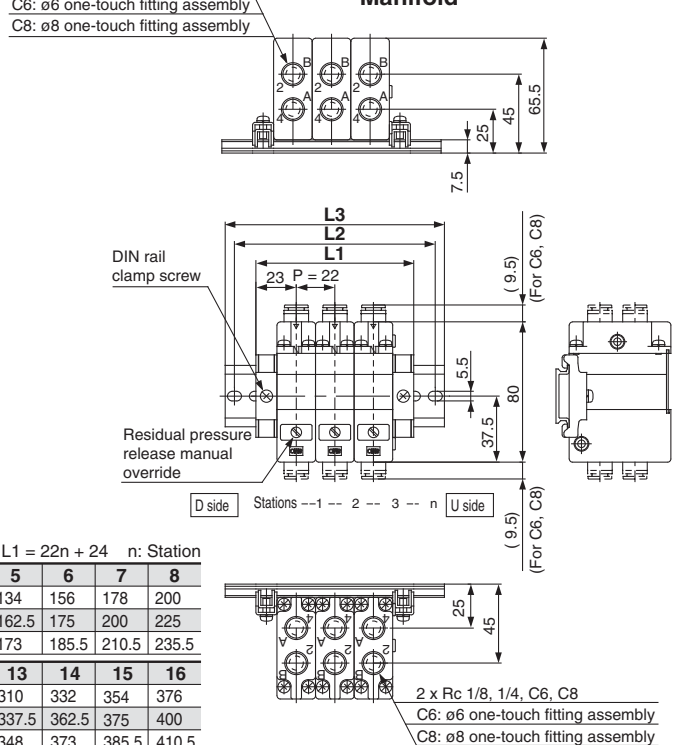

### Dimensions

Formula L1 = 22n + 24 n: Station

n	1	2	3	4	5	6	7	8
L1	46	68	90	112	134	156	178	200
L2	75	87.5	112.5	137.5	162.5	175	200	225
L3	85.5	98	123	148	173	185.5	210.5	235.5

n	9	10	11	12	13	14	15	16
L1	222	244	266	288	310	332	354	376
L2	250	262.5	287.5	312.5	337.5	362.5	375	400
L3	260.5	273	298	323	348	373	385.5	410.5

## How to Order

### Double check block

VQ2000-FPG-01 01 - F

### IN side port size

01	Rc 1/8
02	Rc 1/4
C6	ø6 one-touch fitting
C8	ø8 one-touch fitting
N7	ø1/4" one-touch fitting
N9	ø5/16" one-touch fitting

### OUT side port size

01	Rc 1/8
02	Rc 1/4
C6	ø6 one-touch fitting
C8	ø8 one-touch fitting
N7	ø1/4" one-touch fitting
N9	ø5/16" one-touch fitting

### Option

-	None
D	DIN rail mounting (For manifold)
F	With bracket
N	Name plate

Note) When two or more symbols are specified, indicate them alphabetically. Example) -DN

### Manifold (DIN rail mounting)

VVQ2000-FPG-06

### Stations

01	1 station
⋮	⋮
16	16 stations

When ordering a double check block, order the DIN rail mounting [-D].

### <Ordering example>

VVQ2000-FPG-06-6-station manifold

\*VQ2000-FPG-C6C6-D, 3set } Double check block  
\*VQ2000-FPG-C8C8-D, 3set }

### Bracket Assembly

Part no.	Tightening torque
VQ2000-FPG-FB	0.8 to 1.0 N·m

### <Example>

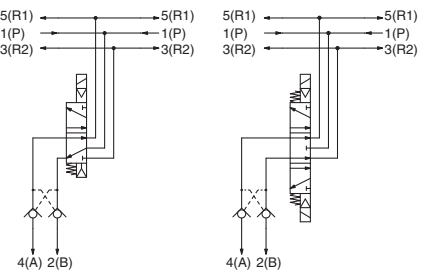

## Caution

- Air leakage from the pipe between the valve and cylinder or from the fittings will prevent the cylinder from stopping for long periods of time. Check the leakage using neutral household detergent, such as dish washing soap. Also, check the cylinder's tube gasket, piston packing and rod packing for air leakage.
- Since one-touch fittings allow slight air leakage, screw piping is recommended when stopping the cylinder in the middle for long periods of time.
- Combining double check block with 3-position closed centre or pressure centre solenoid valve will not work.
- When fittings, etc. are being screwed to the double check block, tighten them with the torque below.

Connection thread	Proper tightening torque (N·m)
Rc 1/8	7 to 9
Rc 1/4	12 to 14

- If the exhaust of the double check block is restricted too much, the cylinder may not operate properly and may not stop intermediately.
- Set the cylinder load so that the cylinder pressure will be within two times that of the supply pressure.





# Series VQC1000/2000

## Specific Product Precautions 1

Be sure to read before handling.

Refer to back cover for Safety Instructions and Handling Precautions for SMC Products (M-E03-3) for 3/4/5 Port Solenoid Valves Precautions.

### Manual Override

#### Warning

Connected actuator is started by manual operation. Use the manual override after confirming that there is no danger. Push type is standard. (Tool required) Locking type is semi-standard. (Tool required)

##### Non-locking push type (Tool required)

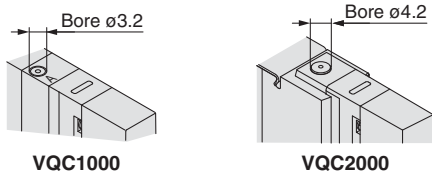

Push down on the manual override with a small screwdriver until it stops. Release the screwdriver and the manual override will return.

##### Locking type (Tool required) <Semi-standard>

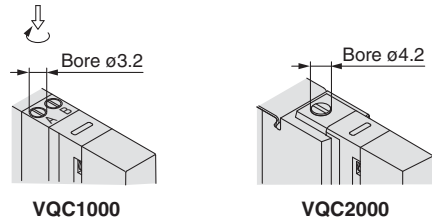

Push down on the manual override with a small flat head screwdriver until it stops. Turn it clockwise by 90 to lock it. Turn it counterclockwise to release it.

##### Locking type (Manual) <Semi-standard>

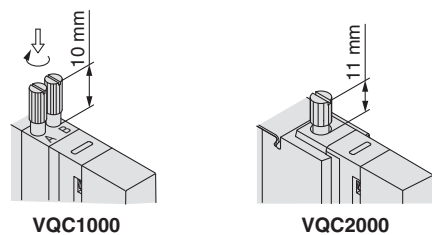

Push down on the manual override with a small screwdriver or with your fingers until it stops. Turn it clockwise by 90 to lock it. Turn it counterclockwise to release it.

#### Caution

Do not apply excessive torque when turning the locking type manual override. (0.1 N·m or less)

#### Warning

##### Slide locking type (Manual) <Semi-standard>

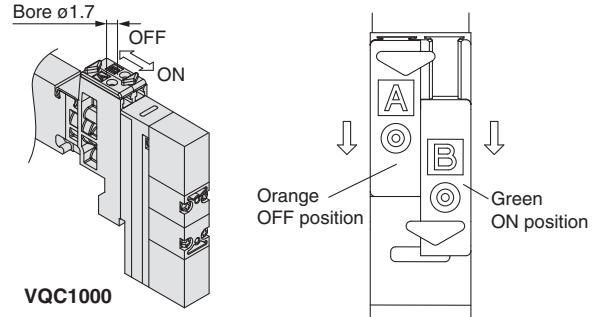

VQC1000

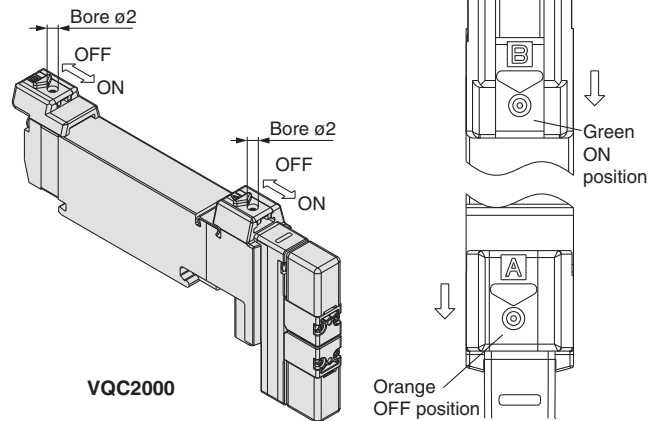

VQC2000

The manual override is locked by sliding it all the way to the pilot valve side (ON side) with a small flat head screwdriver or with your fingers. Slide it to the fitting side (OFF side) to release it. In addition, it can also be used as a push type by using a screwdriver, etc., of ø1.7 or less. (ø2 or less for VQC2000)

### How to Mount/Remove Solenoid Valves

#### Caution

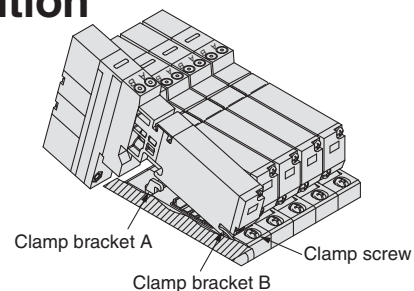

##### Removing

1. Loosen the clamp screw until it turns freely. (The screw is captive.)
2. Lift the coil side of the valve body while pressing down slightly on the screw head and remove it from the clamp bracket B. When the screw head cannot be pressed easily, gently press the area near the manual override of the valve.

##### Mounting

1. Press down on the clamp screw. Clamp bracket A opens. Diagonally insert the hook on the valve end plate side into clamp B.
2. Press the valve body downward. (When the screw is released, it will be locked by clamp bracket A.)
3. Tighten the clamp screw. (Proper tightening torque: VQC1000, 0.25 to 0.35 N·m; VQC2000, 0.5 to 0.7 N·m)

#### Caution

Dust on the sealing surface of the gasket or solenoid valve can cause air leakage.



# Series VQC1000/2000 Specific Product Precautions 2

Be sure to read before handling.

Refer to back cover for Safety Instructions and Handling Precautions for SMC Products (M-E03-3) for 3/4/5 Port Solenoid Valves Precautions.

## Cylinder Port Fittings Replacement

### ⚠ Caution

One-touch fittings on the cylinder port are a cassette for easy replacement. The fittings are blocked by a clip. After removing the corresponding valve and take out the clip with a flat head screwdriver, etc., then replace the fittings.

For mounting, insert the fitting until it strikes against the inside wall and then insert the clip to the specified position.

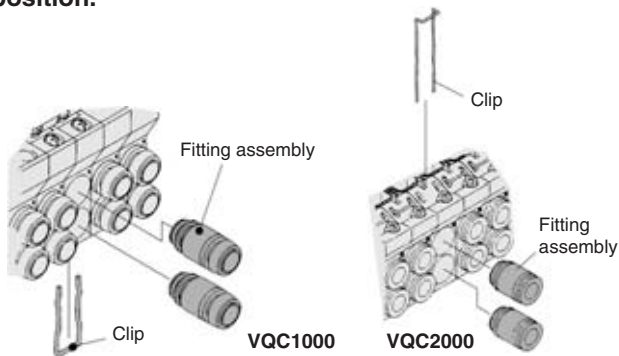

Applicable tubing O.D.	Fitting assembly part no.	
	VQC1000	VQC2000
Applicable tubing ø3.2	VVQ1000-50A-C3	—
Applicable tubing ø4	VVQ1000-50A-C4	VVQ1000-51A-C4
Applicable tubing ø6	VVQ1000-50A-C6	VVQ1000-51A-C6
Applicable tubing ø8	—	VVQ1000-51A-C8
M5	VVQ1000-50A-M5	—
Applicable tubing ø1/8"	VVQ1000-50A-N1	—
Applicable tubing ø5/32"	VVQ1000-50A-N3	VVQ1000-51A-N3
Applicable tubing ø1/4"	VVQ1000-50A-N7	VVQ1000-51A-N7
Applicable tubing ø5/16"	—	VVQ1000-51A-N9

Note) Refer to "Manifold Optional Parts" on pages 51 and 54 for other types of fittings.

### ⚠ Caution

- 1) Use caution that O-rings must be free from scratches and dust. Otherwise, air leakage may result.
- 2) After screwing in the fittings, mount the M5 fitting assembly on the manifold base. (Tightening torque: 0.8 to 1.2 N·m)
- 3) Purchasing order is available in units of 10 pieces.

## Light/Surge Voltage Suppressor

### ⚠ Caution

The lighting positions are concentrated on one side for both single solenoid type and double solenoid type. In the double solenoid type, A side and B side energization are indicated by two colours which match the colours of the manual overrides.

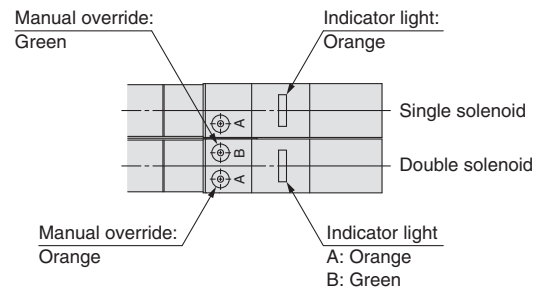

(Drawing shows a VQC1000 case.)

### DC circuit diagram

#### Single solenoid

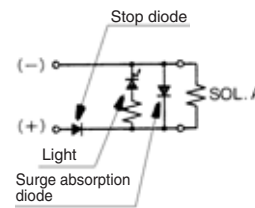

#### Double solenoid

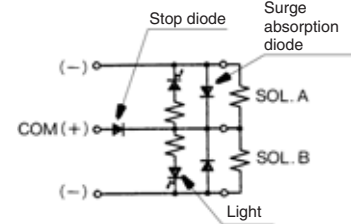

Note) A-side energization:

A light (Orange) illuminates.

B-side energization:

B light (Green) illuminates.

With wrong wiring prevention (stop diode) mechanism

With a surge absorption (surge absorption diode) mechanism



# Series VQC1000/2000

## Specific Product Precautions 3

Be sure to read before handling.

Refer to back cover for Safety Instructions and Handling Precautions for SMC Products (M-E03-3) for 3/4/5 Port Solenoid Valves Precautions.

### How to Mount/Remove DIN Rail

#### Caution

##### Removing

1. Loosen the clamp screw on side (a) of the end plate on both sides.
2. Lift side (a) of the manifold base and slide the end plate in the direction of (2) shown in the figure to remove.

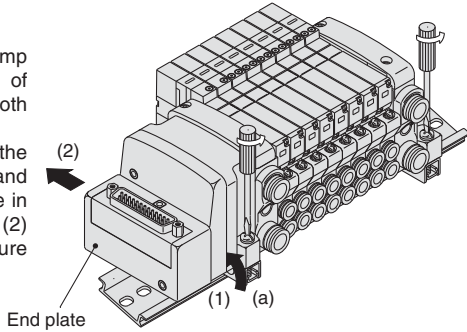

##### Mounting

1. Hook side (b) of the manifold base on the DIN rail.
2. Press down side (a) and mount the end plate on the DIN rail. Tighten the clamp screw on side (a) of the end plate. The proper tightening torque for screws is 0.4 to 0.6 N·m.

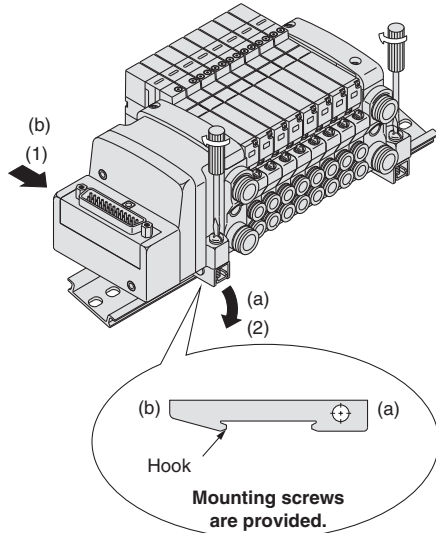

### IP67 Enclosure

#### Caution

Wiring connection for models conforming to IP67 should also have enclosures equivalent to or of stricter than IP67.

### Built-in Silencer Element

#### Caution

A filter element is incorporated in the end plate on both sides of the manifold base. A dirty and choked element may reduce cylinder speed or cause malfunction. Clean or replace the dirty element.

##### Element Part No.

Type	Element part no.	
	VQC1000	VQC2000
Direct EXH outlet with built-in silencer	VVQ1000-82A-1	VVQ2000-82A-1

The minimum order quantity is 10 pcs.

Remove the cover from the top of the end plate and remove the old element with a flat head screwdriver, etc.

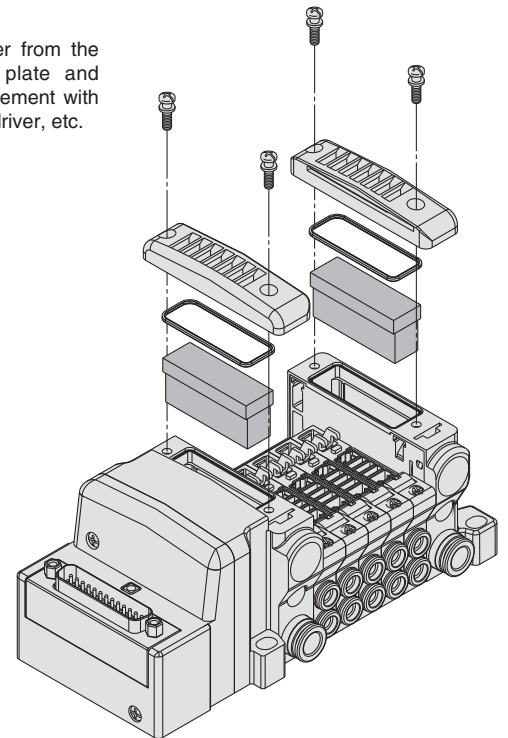

### How to Calculate Flow Rate

Refer to Best Pneumatics No. ① for obtaining the flow rate.



## Series VQC1000/2000

# Specific Product Precautions 4

Be sure to read before handling.

Refer to back cover for Safety Instructions and Handling Precautions for SMC Products (M-E03-3) for 3/4/5 Port Solenoid Valves Precautions.

### EX500/EX260/EX250/EX126 Precautions

#### Warning

1. **These products are intended for use in general factory automation equipment.**  
Avoid using these products in machinery/equipment which affects human safety, and in cases where malfunction or failure can result in extensive damage.
2. **Do not use in explosive environments, in the presence of inflammable gases, or in corrosive environments. This can cause injury or fire.**
3. **Work such as transporting, installing, piping, wiring, operation, control and maintenance should be performed by knowledgeable and qualified personnel only. As handling involves the risk of a danger of electrocution, injury or fire.**
4. **Install an external emergency stop circuit that can promptly stop operation and shut off the power supply.**
5. **Do not modify these products. Modifications done to**

#### Caution

1. **Read the instruction manual carefully, strictly observe the precautions and operate within the range of the specifications.**
2. **Do not drop these products or submit them to strong impacts. This can cause damage, failure or malfunction.**
3. **In locations with poor electrical conditions, take steps to ensure a steady flow of the rated power supply. Use of a voltage outside of the specifications can cause malfunction, damage to the unit, electrocution or fire.**
4. **Do not touch connector terminals or internal circuit elements when current is being supplied. There is a danger of malfunction, damage to the unit or electrocution if connector terminals or internal circuit elements are touched when current is being supplied.**  
Be sure that the power supply is OFF when adding or removing manifold valves or input blocks or when connecting or disconnecting connectors.
5. **Operate at an ambient temperature that is within the specifications. Even when the ambient temperature range is within the specifications, do not use in locations where there are rapid temperature changes.**
6. **Keep wire scraps and other extraneous materials from getting inside these products. This can cause fire, failure or malfunction.**
7. **Give consideration to the operating environment depending on the type of enclosure being used.**  
To achieve IP65 and IP67 protection class, provide appropriate wiring between all units using electrical wiring cables, communication connectors and cables with M12 connectors. Also, provide waterproof caps when there are unused ports, and perform proper mounting of input units, input blocks, SI units and manifold valves. Provide a cover or other protection for applications in which there is constant exposure to water.
8. **Use the proper tightening torques.**  
There is a possibility of damaging threads if tightening exceeds the tightening torque range.
9. **Provide adequate protection when operating in locations such as follows:**
  - Where noise is generated by static electricity
  - Where there is a strong electric field
  - Where there is a danger of exposure to radiation
  - When in close proximity to power supply lines

#### Caution

10. **When these products are installed in equipment, provide adequate protection against noise by using noise filters.**
11. **Since these products are components whose end usage is obtained after installation in other equipment, the customer should confirm conformity to EMC directives for the finished product.**
12. **Do not remove the name plate.**
13. **Perform periodic inspections and confirm normal operation, otherwise it may be impossible to guarantee safety due to unexpected malfunction or erroneous operation.**

#### Safety Instructions on Power Supply

#### Caution

1. **Operation is possible with a single power supply or a separate power supply. However, be sure to provide two wiring systems (one for solenoid valves, and one for input and control units).**
2. **When it is UL compliant, use a class 2 power supply unit in accordance with UL1310 for a combined direct current power supply.**

#### Safety Instructions on Cable

#### Caution

1. **Avoid miswiring, as this can cause malfunction, damage and fire in the unit.**
2. **To prevent noise and surge in signal lines, keep all wiring separate from power lines and high-voltage lines. Otherwise, this can cause malfunction.**
3. **Check wiring insulation, as defective insulation can cause damage to the unit when excessive voltage or current is applied.**
4. **Do not bend or pull cables repeatedly, and do not place heavy objects on them or allow them to be pinched. This can cause broken lines.**



# Series VQC1000/2000

## Specific Product Precautions 5

Be sure to read before handling.

Refer to back cover for Safety Instructions and Handling Precautions for SMC Products (M-E03-3) for 3/4/5 Port Solenoid Valves Precautions.

### EX600 Precautions

#### Design/Selection

##### Warning

- 1. Use this product within the specification range.**  
Using beyond the specified specifications range can cause fire, malfunction, or damage to the system. Confirm the specifications when operating.
- 2. When using for an interlock circuit:**
  - Provide a multiple interlock system which is operated by another system (such as mechanical protection function).
  - Perform an inspection to check that it is working properly.

This may cause possible injury due to malfunction.

##### Caution

- 1. When it is UL compliant, use a class 2 power supply unit in accordance with UL1310 for a combined direct current power supply.**
- 2. Use this product within the specified voltage range.**  
Using beyond the specified voltage range is likely to cause the units and connecting devices to be damaged or to malfunction.
- 3. The power supply for the unit should be 0 V as the standard for both power supply for output as well as power supply for control/input.**

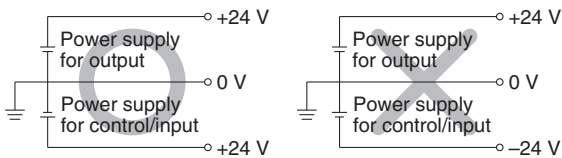

- 4. Do not install a unit in a place where it can be used as a foothold.**  
Applying any excessive load such as stepping on the unit by mistake or placing a foot on it, will cause it to break.
- 5. Keep the surrounding space free for maintenance.**  
When designing a system, take into consideration the amount of free space needed for performing maintenance.
- 6. Do not remove the name plate.**  
Improper maintenance or incorrect use of instruction manual can cause failure and malfunction. Also, there is a risk of losing conformity with safety standards.
- 7. Beware of inrush current when the power supply is turned on.**  
Some connected loads can apply an initial charge current which will trigger the over current protection function, causing the unit to malfunction.

#### Mounting

##### Caution

- 1. When handling and assembling units:**
  - Do not touch the sharp metal parts of the connector or plug.
  - Do not apply excessive force to the unit.  
The connecting portions of the unit are firmly joined with seals.
  - When joining units, take care not to get fingers caught between units.  
Injury can result.
- 2. Do not drop, bump, or apply excessive impact.**  
Otherwise, the unit can become damaged, malfunction, or fail to function.
- 3. Observe the tightening torque range.**  
Tightening outside of the allowable torque range will likely damage the product.  
IP67 protection class cannot be guaranteed if the screws are not tightened to the specified torque.
- 4. When lifting a large size manifold solenoid valve unit, take care to avoid causing stress to the valve connection joint.**  
The connection parts of the unit may be damaged.  
Because the unit may be heavy, carrying and installation should be performed by more than one operator to avoid strain or injury.
- 5. When placing a manifold, mount it on a flat surface.**  
Torsion in the whole manifold can lead to trouble such as air leakage or defective insulation.

#### Wiring

##### Caution

- 1. Confirm grounding to maintain the safety of the reduced wiring system and for anti-noise performance.**  
Provide a specific grounding as close to the unit as possible to minimise the distance to grounding.
- 2. Avoid repeatedly bending or stretching the cable and applying a heavy object or force to it.**  
Wiring applying repeated bending and tensile stress to the cable can break the circuit.
- 3. Avoid miswiring.**  
If miswired, there is a danger of malfunction or damage to the reduced wiring system.
- 4. Do not wire while energizing the product.**  
There is a danger of malfunction or damage to the reduced wiring system or input/output equipment.





## Series VQC1000/2000

# Specific Product Precautions 6

Be sure to read before handling.

Refer to back cover for Safety Instructions and Handling Precautions for SMC Products (M-E03-3) for 3/4/5 Port Solenoid Valves Precautions.

### EX600 Precautions

#### Wiring

#### Caution

- 5. Avoid wiring the power line and high-pressure line in parallel.**  
Noise or surge produced by signal line resulting from the power line or high pressure line could cause malfunction. Wiring of the reduced wiring system or input/output device and the power line or high-pressure line should be separated from each other.
- 6. Confirm the wiring insulation.**  
Defective insulation (contact with other circuits, improper insulation between terminals, etc.) may cause damage to the reduced wiring system or input/output device due to excessive voltage or current.
- 7. When a reduced wiring system is installed in machinery/equipment, provide adequate protection against noise by using noise filters, etc.**  
Noise in signal lines may cause malfunction.
- 8. When connecting wires of input/output device or handheld terminal, prevent water, solvent or oil from entering inside from the connector section.**  
This can cause damage, equipment failure, or malfunction.
- 9. Avoid wiring patterns in which excessive stress is applied to the connector.**  
This may cause malfunction or damage to the unit due to contact failure.

#### Operating Environment

#### Warning

- 1. Do not use in an atmosphere containing an inflammable gas or explosive gas.**  
Use in such an atmosphere is likely to cause a fire or explosion. This system is not explosion-proof.

#### Caution

- 1. Select the proper type of enclosure according to the environment of operation.**  
IP65/67 protection class is achieved when the following conditions are met.
  - 1) The units are connected properly with wiring cable for power supply, communication connector, and cable with M12 connector.
  - 2) Suitable mounting of each unit and manifold valve.
  - 3) Be sure to mount a seal cap on any unused connectors.For IP40 protection class, do not use in atmospheres with corrosive gas, chemicals, sea water, water, steam, or where there is direct contact with any of these. When EX600-D□□E or EX600-D□□F are connected, the enclosure of the manifold should be IP40. Also, the Handheld Terminal conforms to IP20, so prevent foreign matter from entering inside, and water, solvent or oil from coming in direct contact with it.

#### Operating Environment

#### Caution

- 2. Provide adequate protection when operating in locations such as the following.**  
Failure to do so may cause damage or malfunction. The effect of countermeasures should be checked in individual equipment and machine.
  - 1) Where noise is generated by static electricity, etc.
  - 2) Where there is a strong electric field
  - 3) Where there is a danger of exposure to radiation
  - 4) When in close proximity to power supply lines
- 3. Do not use in an environment where oil and chemicals are used.**  
Operating in environments with coolants, cleaning solvents, various oils or chemicals may cause adverse effects (damage, malfunction) to the unit even in a short period of time.
- 4. Do not use in an environment where the product could be exposed to corrosive gas or liquid.**  
This may damage the unit and cause it to malfunction.
- 5. Do not use in locations with sources of surge generation.**  
Installation of the unit in an area around the equipment (electromagnetic lifters, high frequency induction furnaces, welding machine, motors etc.), which generates the large surge voltage could cause to deteriorate an internal circuitry element of the unit or result in damage. Implement countermeasures against the surge from the generating source, and avoid touching the lines with each other.
- 6. Use the product type that has an integrated surge absorption element when directly driving a load which generates surge voltage by relay, solenoid valves or lamp.**  
When a surge generating load is directly driven, the unit may be damaged.
- 7. The product is CE marked, but not immune to lightning strikes. Take measures against lightning strikes in your system.**
- 8. Keep dust, wire scraps and other extraneous material from getting inside the product.**  
This may cause malfunction or damage.
- 9. Mount the unit in such locations, where no vibration or shock is affected.**  
This may cause malfunction or damage.
- 10. Do not use in places where there are cyclic temperature changes.**  
In case that the cyclic temperature is beyond normal temperature changes, the internal unit is likely to be adversely effected.
- 11. Do not use in direct sunlight.**  
Do not use in direct sunlight. It may cause malfunction or damage.
- 12. Use this product within the specified ambient temperature range.**  
This may cause malfunction.
- 13. Do not use in places where there is radiated heat around it.**  
Such a place is likely to cause malfunction.



# Series VQC1000/2000

## Specific Product Precautions 7

Be sure to read before handling.

Refer to back cover for Safety Instructions and Handling Precautions for SMC Products (M-E03-3) for 3/4/5 Port Solenoid Valves Precautions.

### EX600 Precautions

#### Adjustment/Operation

#### ⚠ Warning

1. **Do not perform operation or setting with wet hands.**  
There is a risk of electrical shock.

#### <Ex600 Handheld Terminal>

2. **Do not apply pressure to the LCD display.**  
There is a possibility of the crack of LCD display and injuring.
3. **The forced input/output function is used to change the signal status forcibly. When operating this function, be sure to check the safety of the surroundings and installation.**  
Otherwise, injury or equipment damage could result.
4. **Incorrect setting of parameters can cause malfunction. Be sure to check the settings before use.**  
This may cause injury or equipment damage.

#### ⚠ Caution

1. **Use a watchmaker's screwdriver with thin blade for the setting of each switch of the SI unit.**  
**When setting the switch, do not touch other unrelated parts.**  
This may cause parts damage or malfunction due to a short circuit.
  2. **Provide adequate setting for the operating conditions.**  
Failure to do so could result in malfunction.  
Refer to the instruction manual for setting of the switches.
  3. **For the details of programming and address setting, refer to the manual from the PLC manufacturer.**  
The content of programming related to protocol is designed by the manufacturer of the PLC used.
- <Ex600 Handheld Terminal>
4. **Do not press the setting buttons with a sharp pointed object.**  
This may cause damage or malfunction.
  5. **Do not apply excessive load and impact to the setting buttons.**  
This may cause damage, equipment failure or malfunction.

When the order does not include the SI unit, the valve plate to connect the manifold and SI unit is not mounted. Use attached valve fixing screws and mount the valve plate.  
(Tightening torque: 0.6 to 0.7 N·m)

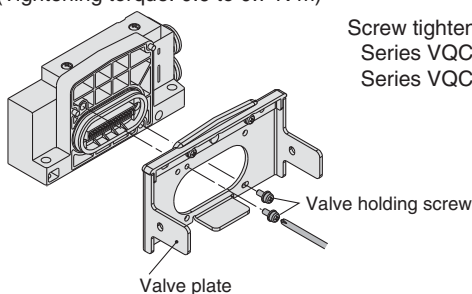

#### Maintenance

#### ⚠ Warning

1. **Do not disassemble, modify (including circuit board replacement) or repair this product.**  
Such actions are likely to cause injuries or breakage.
2. **When an inspection is performed,**
  - Turn off the power supply.
  - Stop the air supply, exhaust the residual pressure in piping and verify that the air is released before performing maintenance work.

Unexpected malfunction of system components and injury can result.

#### ⚠ Caution

1. **When handling and replacing the unit:**
  - Do not touch the sharp metal parts of the connector or plug.
  - Do not apply excessive force to the unit.  
The connecting portions of the unit are firmly joined with seals.
  - When joining units, take care not to get fingers caught between units.  
Injury can result.
2. **Perform periodic inspection.**  
Unexpected malfunction in the system composition devices is likely to occur due to malfunction of machinery or equipment.
3. **After maintenance, make sure to perform an appropriate functionality inspection.**  
In cases of abnormality such as faulty operation, stop operation. Unexpected malfunction in the system composition devices is likely to occur.
4. **Do not use benzene and thinner for cleaning units.**  
Damage to the surface or erasure of the display can result. Wipe off any stains with a soft cloth. If the stain is persistent, wipe off with a cloth soaked in a dilute solution of neutral detergent and wrung out tightly, and then finish with a dry cloth.



#### ■ Trademark

DeviceNet™ is a trademark of ODVA.

Product names described in this catalogue may be used as trademarks by each manufacturer.

## Safety Instructions

These safety instructions are intended to prevent hazardous situations and/or equipment damage. These instructions indicate the level of potential hazard with the labels of “Caution,” “Warning” or “Danger.” They are all important notes for safety and must be followed in addition to International Standards (ISO/IEC)\*1), and other safety regulations.

-  **Caution:** Caution indicates a hazard with a low level of risk which, if not avoided, could result in minor or moderate injury.
-  **Warning:** Warning indicates a hazard with a medium level of risk which, if not avoided, could result in death or serious injury.
-  **Danger:** Danger indicates a hazard with a high level of risk which, if not avoided, will result in death or serious injury.

- \*1) ISO 4414: Pneumatic fluid power – General rules relating to systems.
- ISO 4413: Hydraulic fluid power – General rules relating to systems.
- IEC 60204-1: Safety of machinery – Electrical equipment of machines. (Part 1: General requirements)
- ISO 10218-1: Manipulating industrial robots - Safety. etc.

### Warning

#### 1. The compatibility of the product is the responsibility of the person who designs the equipment or decides its specifications.

Since the product specified here is used under various operating conditions, its compatibility with specific equipment must be decided by the person who designs the equipment or decides its specifications based on necessary analysis and test results. The expected performance and safety assurance of the equipment will be the responsibility of the person who has determined its compatibility with the product. This person should also continuously review all specifications of the product referring to its latest catalogue information, with a view to giving due consideration to any possibility of equipment failure when configuring the equipment.

#### 2. Only personnel with appropriate training should operate machinery and equipment.

The product specified here may become unsafe if handled incorrectly. The assembly, operation and maintenance of machines or equipment including our products must be performed by an operator who is appropriately trained and experienced.

#### 3. Do not service or attempt to remove product and machinery/equipment until safety is confirmed.

1. The inspection and maintenance of machinery/equipment should only be performed after measures to prevent falling or runaway of the driven objects have been confirmed.
2. When the product is to be removed, confirm that the safety measures as mentioned above are implemented and the power from any appropriate source is cut, and read and understand the specific product precautions of all relevant products carefully.
3. Before machinery/equipment is restarted, take measures to prevent unexpected operation and malfunction.

#### 4. Contact SMC beforehand and take special consideration of safety measures if the product is to be used in any of the following conditions.

1. Conditions and environments outside of the given specifications, or use outdoors or in a place exposed to direct sunlight.
2. Installation on equipment in conjunction with atomic energy, railways, air navigation, space, shipping, vehicles, military, medical treatment, combustion and recreation, or equipment in contact with food and beverages, emergency stop circuits, clutch and brake circuits in press applications, safety equipment or other applications unsuitable for the standard specifications described in the product catalogue.
3. An application which could have negative effects on people, property, or animals requiring special safety analysis.
4. Use in an interlock circuit, which requires the provision of double interlock for possible failure by using a mechanical protective function, and periodical checks to confirm proper operation.

## Limited warranty and Disclaimer/ Compliance Requirements

The product used is subject to the following “Limited warranty and Disclaimer” and “Compliance Requirements”.

Read and accept them before using the product.

### Limited warranty and Disclaimer

1. The warranty period of the product is 1 year in service or 1.5 years after the product is delivered, whichever is first.\*2) Also, the product may have specified durability, running distance or replacement parts. Please consult your nearest sales branch.
2. For any failure or damage reported within the warranty period which is clearly our responsibility, a replacement product or necessary parts will be provided. This limited warranty applies only to our product independently, and not to any other damage incurred due to the failure of the product.
3. Prior to using SMC products, please read and understand the warranty terms and disclaimers noted in the specified catalogue for the particular products.

\*2) Vacuum pads are excluded from this 1 year warranty.

A vacuum pad is a consumable part, so it is warranted for a year after it is delivered.

Also, even within the warranty period, the wear of a product due to the use of the vacuum pad or failure due to the deterioration of rubber material are not covered by the limited warranty.

### Compliance Requirements

1. The use of SMC products with production equipment for the manufacture of weapons of mass destruction (WMD) or any other weapon is strictly prohibited.
2. The exports of SMC products or technology from one country to another are governed by the relevant security laws and regulations of the countries involved in the transaction. Prior to the shipment of a SMC product to another country, assure that all local rules governing that export are known and followed.

### Caution

#### 1. The product is provided for use in manufacturing industries.

The product herein described is basically provided for peaceful use in manufacturing industries.

If considering using the product in other industries, consult SMC beforehand and exchange specifications or a contract if necessary.

If anything is unclear, contact your nearest sales branch.

### Caution

#### SMC products are not intended for use as instruments for legal metrology.

Measurement instruments that SMC manufactures or sells have not been qualified by type approval tests relevant to the metrology (measurement) laws of each country.

Therefore, SMC products cannot be used for business or certification ordained by the metrology (measurement) laws of each country.

## Safety Instructions

Be sure to read “Handling Precautions for SMC Products” (M-E03-3) before using.

### SMC Corporation (Europe)

Austria	☎ +43 (0)2262622800	www.smc.at	office@smc.at	Lithuania	☎ +370 5 2308118	www.smclt.lt	info@smclt.lt
Belgium	☎ +32 (0)33551464	www.smcpn pneumatics.be	info@smcpneumatics.be	Netherlands	☎ +31 (0)205318888	www.smcpn pneumatics.nl	info@smcpneumatics.nl
Bulgaria	☎ +359 (0)2807670	www.smc.bg	office@smc.bg	Norway	☎ +47 67129020	www.smc-norge.no	office@smc-norge.no
Croatia	☎ +385 (0)13707288	www.smc.hr	office@smc.hr	Poland	☎ +48 222119600	www.smc.pl	post@smc.pl
Czech Republic	☎ +420 541424611	www.smc.cz	office@smc.cz	Portugal	☎ +351 226166570	www.smc.eu	postpt@smc.smces.es
Denmark	☎ +45 70252900	www.smcdk.com	smc@smcdk.com	Romania	☎ +40 213205111	www.smcromania.ro	smcromania@smcromania.ro
Estonia	☎ +372 6510370	www.smcpn pneumatics.ee	smc@smcpneumatics.ee	Russia	☎ +7 8127185445	www.smc-pneumatik.ru	info@smc-pneumatik.ru
Finland	☎ +358 207513513	www.smc.fi	smc@smc.fi	Slovakia	☎ +421 (0)413213212	www.smc.sk	office@smc.sk
France	☎ +33 (0)164761000	www.smc-france.fr	info@smc-france.fr	Slovenia	☎ +386 (0)73885412	www.smc.si	office@smc.si
Germany	☎ +49 (0)61034020	www.smc.de	info@smc.de	Spain	☎ +34 902184100	www.smc.es	post@smc.smces.es
Greece	☎ +30 210 2717265	www.smchellas.gr	sales@smchellas.gr	Sweden	☎ +46 (0)86031200	www.smc.se	post@smc.se
Hungary	☎ +36 23511390	www.smc.hu	office@smc.hu	Switzerland	☎ +41 (0)523963131	www.smc.ch	info@smc.ch
Ireland	☎ +353 (0)14039000	www.smcpn pneumatics.ie	sales@smcpneumatics.ie	Turkey	☎ +90 212 489 0 440	www.smcpn pneumatik.com.tr	info@smcpneumatik.com.tr
Italy	☎ +39 0292711	www.smcitalia.it	mailbox@smcitalia.it	UK	☎ +44 (0)845 121 5122	www.smcpn pneumatics.co.uk	sales@smcpneumatics.co.uk
Latvia	☎ +371 67817700	www.smc.lv	info@smc.lv				

SMC CORPORATION Akihara UDX 15F, 4-14-1, Sotokanda, Chiyoda-ku, Tokyo 101-0021, JAPAN Phone: 03-5207-8249 FAX: 03-5298-5362