

- Овальное сечение поршня обеспечивает компактность при сохранении выходного усилия.
- Ширина от 24 мм (для типоразмера Ø25) до 50 мм (для типоразмера Ø63).
- Установка компактных датчиков положения возможна на четырех поверхностях. Датчик положения не выступает из монтажного паза, что предотвращает его повреждение.
- Длины хода до 300 мм.
- Возможен монтаж без крепежных элементов.
- Исполнения двустороннего действия с двусторонним штоком, одностороннего действия с пружинным выдвиганием/возвратом (по запросу)



Технические характеристики

Диаметр поршня (мм)	25	32	40	50	63
Диаметр штока (мм)	12	14	16	20	
Принцип действия	Двустороннего действия с односторонним штоком				
Среда	Очищенный сжатый воздух				
Испытательное давление (МПа)	1.05				
Диапазон рабочих давлений (МПа)	0,05 ~ 0,7				
Стандартные длины хода, мм	5, 10, 15, 20, 25, 30, 35, 40, 45, 50, 75, 100, 125, 150, 175, 200, 250, 300				
Смазка	Не требуется				
Допуск по длине хода (мм)	+1,4 0				
Температура рабочей и окружающей среды (°C)	-10 ~ 60				
Скорость поршня (мм/с)	50 ~ 500				
Демпфирование	Упругое				
Допустимый крутящий момент (Н·м)	0.25		0.55	1.25	2
Допуск на проворот штока	±1°	±0.8°	±0.5°		

* Промежуточные длины хода по запросу.

Теоретическое усилие (Н)



Типоразмер	Направление действия	S поршня (мм²)	Рабочее давление (МПа)					
			0.2	0.3	0.4	0.5	0.6	0.7
25	OUT	491	98	147	196	246	295	344
	IN	378	76	113	151	189	227	265
32	OUT	804	161	241	322	402	482	563
	IN	650	130	195	260	325	390	455
40	OUT	1257	251	377	503	629	754	880
	IN	1056	211	317	422	528	634	739
50	OUT	1963	393	589	785	982	1178	1374
	IN	1649	330	495	660	824	989	1154
63	OUT	3117	623	935	1247	1559	1870	2182
	IN	2803	561	841	1121	1402	1682	1962

* Теоретическое усилие при выдвигании поршня (Н) = Давление (МПа) x S поршня (мм²)

Вес пневмоцилиндра и крепежных элементов (кг)

Типоразмер		25	32	40	50	63
Базовый вес	Базовое крепление	0.17	0.27	0.39	0.75	1.16
	На лапах	0.24	0.41	0.60	1.09	1.79
	На фланце	0.27	0.41	0.62	1.21	1.99
	На одинарной опоре	0.23	0.39	0.61	1.15	1.84
	На проушине	0.24	0.43	0.65	1.22	1.92
Дополнительный вес на каждые 50 мм хода		0.09	0.14	0.19	0.28	0.38
Крепежные элементы	Одинарная опора	0.06	0.12	0.22	0.40	0.68
	Проушина	0.07	0.16	0.26	0.47	0.76
	Шарнирный наконечник штока	0.03	0.04	0.07	0.16	0.16
	Наконечник-вилка	0.05	0.09	0.14	0.29	0.29

Датчики положения

Для цилиндров серии MDU используются электронные датчики положения D-M9N, D-M9P, D-M9B и герконовые датчики положения D-A90, D-A93, D-A96. На цилиндры типоразмеров 40 и 63 возможна установка устойчивых к магнитным полям датчиков положения D-P3DW. Минимальная длина хода при использовании датчиков положения – 10 мм.

Номер для заказа

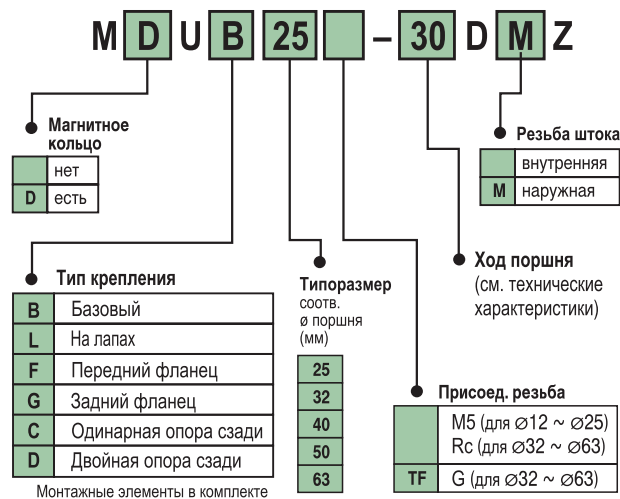

Запасные части и принадлежности

заказываются отдельно

Ремкомплект (комплект уплотнений)

Типоразмер	Номер для заказа
25	MUB25-PS
32	MUB32-PS
40	MUB40-PS
50	MUB50-PS
63	MUB63-PS

Крепежные элементы

Крепежный элемент	Типоразмер				
	25	32	40	50	63
Лапа ¹⁾	MU-L02	MU-L03	MU-L04	MU-L05	MU-L06
Фланец	MU-F02	MU-F03	MU-F04	MU-F05	MU-F06
Одинарная опора	MU-C02	MU-C03	MU-C04	MU-C05	MU-C06
Проушина ³⁾	MU-D02	MU-D03	MU-D04	MU-D05	MU-D06
Шарнирный наконечник штока	I-MU02	I-MU03	I-MU04	I-MU05	
Наконечник-вилка ⁴⁾	Y-MU02	Y-MU03	Y-MU04	Y-MU05	

- 1) Для одного цилиндра следует заказывать две лапы.
- 2) Комплекты лапы, фланца и одинарной опоры включают установочные винты.
- 3) Палец, стопорное кольцо и установочные винты в комплекте.
- 4) Палец и стопорное кольцо в комплекте.

Датчики положения заказываются отдельно.

Plate Cylinder

New

NEW Series *MU* $\phi 25$, $\phi 32$, $\phi 40$, $\phi 50$, $\phi 63$

It is possible to mount small auto switches
in 4 directions. No stick-out
Easy mounting

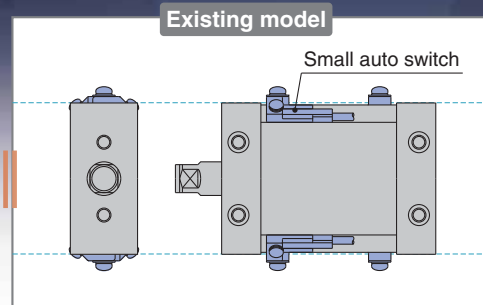
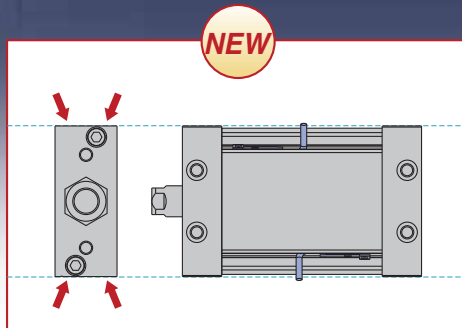

Reduction of labor for work

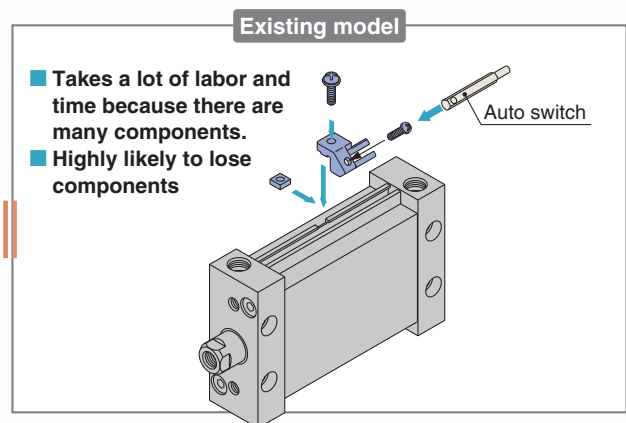
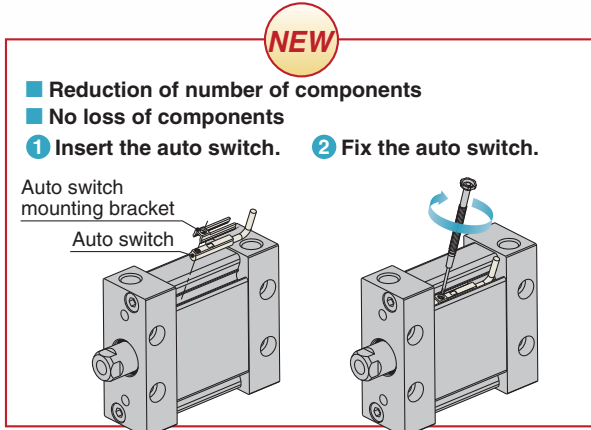

Available with a stroke up to 300 mm

Series MU



CAT.ES20-208A

Series MU



- **Width: Max. 62% reduction**
(in comparison with SMC CA2 cylinder)

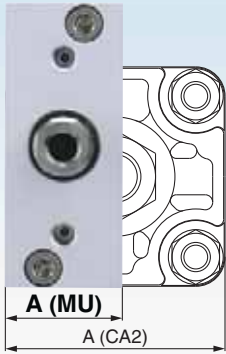

A Dimension Comparison (mm)

Size	A		
	MU	CA2	Reduction rate
25	24	60	60%
32	28	70	60%
40	32	85	62%
50	39	102	62%
63	50	116	57%

- **Can be mounted without brackets and in flexible ways.**

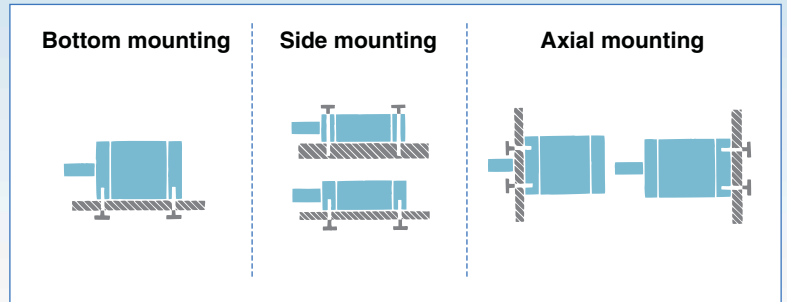

- **Can be mounted with short pitch.**

* Without auto switch

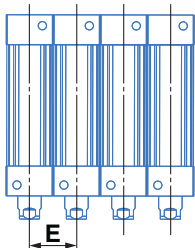

Size	E (mm)
25	24
32	28
40	32
50	39
63	50

Note) When the auto switch is mounted, the minimum mounting pitch is restricted as shown in back page 3.

- **Various brackets are available to accommodate a wide range of applications.**

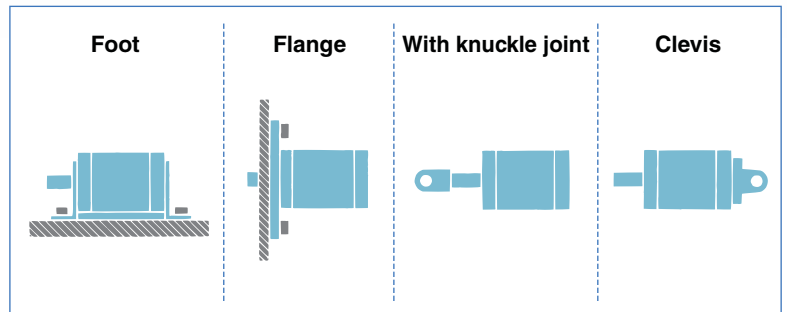

2-Color Indication Solid State Auto Switch

Appropriate setting of the mounting position can be performed without mistakes.



A **green** light lights up at the optimum operating position.

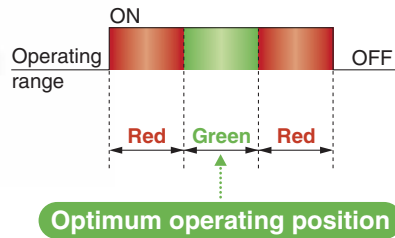

- **For general environments**

- **Water resistant type**
For environments exposed to water and coolant

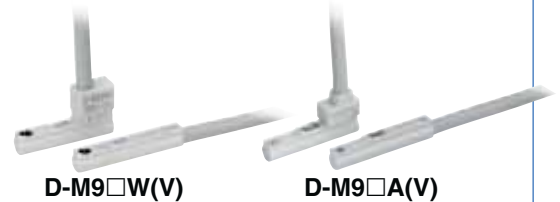

Series Variations

Action	Type	Size	Standard stroke (mm)																Rod end configuration	
			5	10	15	20	25	30	35	40	45	50	75	100	125	150	175	200		250
Double acting	Single rod	25	●	●	●	●	●	●	●	●	●	●	●	●	●	●	●	●	●	Male thread, Female thread
	Double rod	32	●	●	●	●	●	●	●	●	●	●	●	●	●	●	●	●	●	
		40	●	●	●	●	●	●	●	●	●	●	●	●	●	●	●	●	●	
		50	●	●	●	●	●	●	●	●	●	●	●	●	●	●	●	●	●	
		63	●	●	●	●	●	●	●	●	●	●	●	●	●	●	●	●	●	
Single acting	Spring return, Spring extend	25	●	●																
		32	●	●																
		40	●	●	●	●														
		50	●	●	●	●	●													
		63	●	●	●	●	●	●												

Features 1



Series MU Rod End Allowable Load

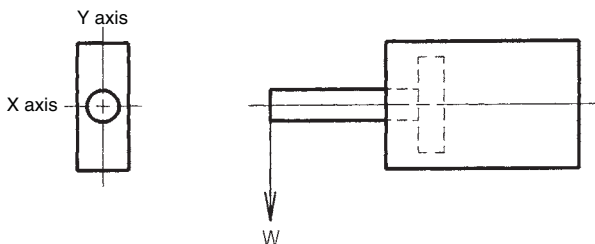

* In case of a plate cylinder, although there is the case that a load is applied in both X and Y axis as illustrated, but the allowable lateral load is the same.

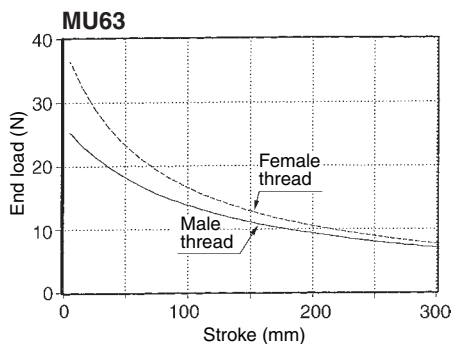
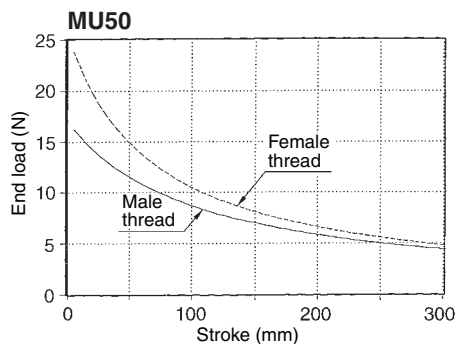
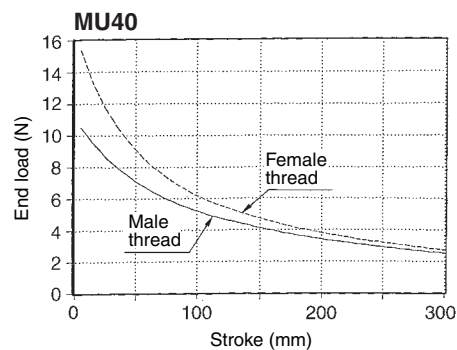
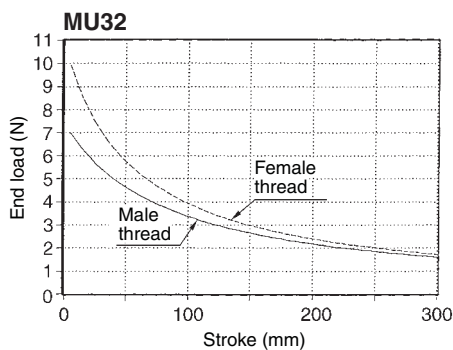
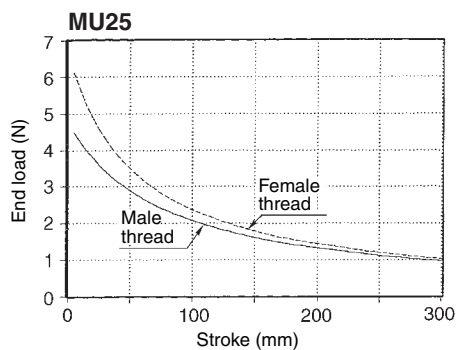

Plate Cylinder Operating Precautions

1. Operating speed

Make sure to connect a speed controller to the cylinder and adjust its speed to 500 mm/s or less.

When a load is applied to the rod end, adjust the speed so that the maximum speed should be no more than that shown in the chart for the corresponding load weight.

<Chart> Series MU

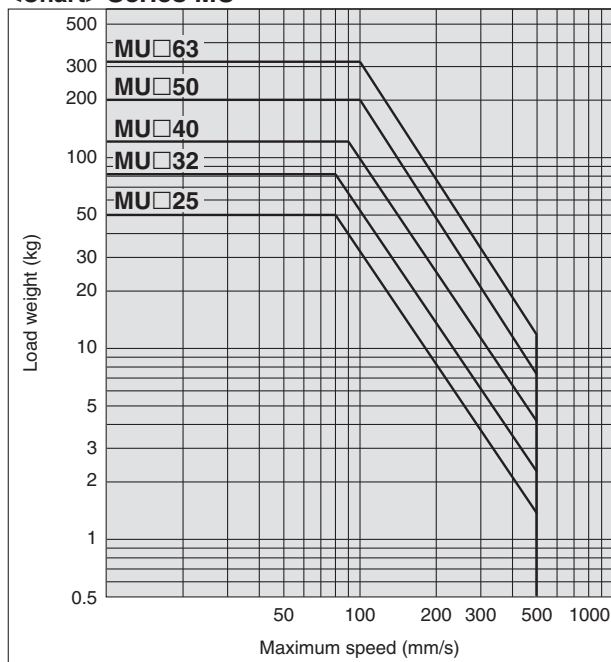

Plate Cylinder: Double Acting, Single Rod Series MU

ø25, ø32, ø40, ø50, ø63

How to Order

MU B 25 [] - 30 D M Z

With auto switch MDU B 25 [] - 30 D M Z - M9BW S

With auto switch (Built-in magnet)

Mounting

B	Basic
L	Foot
F	Rod flange
G	Head flange
C	Single clevis
D	Double clevis

* Brackets are shipped together, (but not assembled).

Size

25	Equiv. ø25 piston area
32	Equiv. ø32 piston area
40	Equiv. ø40 piston area
50	Equiv. ø50 piston area
63	Equiv. ø63 piston area

Port thread type

Nil	M thread	ø25
	Rc	
TN	NPT	ø32, ø40
TF	G	ø50, ø63

Number of auto switches

Nil	2 pcs.
S	1 pc.
n	"n" pcs.

Auto switch

Nil	Without auto switch
-----	---------------------

* Refer to the below table for applicable auto switch models.

Rod end configuration

Nil	Rod end female thread
M	Rod end male thread

Action

D	Double acting
---	---------------

Cylinder stroke (mm)
Refer to "Standard Stroke" on page 2.

Built-in Magnet Cylinder Model
If a built-in magnet cylinder without an auto switch is required, there is no need to enter the symbol for the auto switch.
(Example) MDUL32-30DZ

Applicable Auto Switches/Refer to Best Pneumatics No. 2 for further information on auto switches.

Type	Special function	Electrical entry	Indicator/light	Wiring (Output)	Load voltage		Auto switch model		Lead wire length (m)				Pre-wired connector	Applicable load				
					DC	AC	Perpendicular	In-line	0.5 (Nil)	1 (M)	3 (L)	5 (Z)						
Solid state auto switch	—	Grommet	Yes	3-wire (NPN)	24 V	5 V, 12 V	—	M9NV	M9N	●	●	●	○	○	IC circuit	Relay, PLC		
				3-wire (PNP)				M9PV	M9P	●	●	●	○	○				
				2-wire				M9BV	M9B	●	●	●	○	○				
				3-wire (NPN)				M9NWV	M9NW	●	●	●	○	○				
	Diagnostic indication (2-color indication)			3-wire (PNP)	M9PWV	M9PW	●	●	●	○	○	○	○	○	○		IC circuit	
				2-wire	M9BWV	M9BW	●	●	●	○	○	○	○	○	○		—	
	Water resistant (2-color indication)			3-wire (NPN)	M9NAV**	M9NA**	○	○	○	●	○	○	○	○	○		IC circuit	
				3-wire (PNP)	M9PAV**	M9PA**	○	○	○	○	●	○	○	○	○		—	
Magnetic field resistant (2-color indication)	2-wire	M9BAV**	M9BA**	○	○	○	●	○	○	○	○	○	—					
	2-wire (Non-polar)	—	P3DW ^{Note 2)}	●	—	●	●	○	○	○	○	○	—					
Reed auto switch	—	Grommet	Yes	3-wire (NPN equivalent)	24 V	5 V	—	A96V	A96	●	—	●	—	—	IC circuit	—		
				2-wire				100 V	A93V	A93	●	—	●	—	—	—	—	Relay, PLC
								100 V or less	A90V	A90	●	—	●	—	—	—	—	IC circuit

* Lead wire length symbols: 0.5 m Nil (Example) M9NV
1 m M (Example) M9NW
3 m L (Example) M9NL
5 m Z (Example) M9NZ

* Solid state auto switches marked with "○" are produced upon receipt of order.

* For details about auto switches with pre-wired connector, refer to Best Pneumatics No. 2.

* Auto switches are shipped together, (but not assembled).

** The water resistant auto switch (D-M9□A/M9□AV) can be mounted, but the product itself is not designed to be water resistant.

Note 1) The D-M9□V/M9□WV/M9□AV/A9□V auto switches cannot be mounted on the ported surface with some cylinder strokes and sizes of fittings. This should be checked beforehand.

Note 2) The magnetic field resistant auto switch (D-P3DW□) is available only with ø40 to ø63 of the existing MU series. Refer to page 23 for the how-to-order.

Plate Cylinder: Double Acting, Single Rod *Series MU*

Specifications

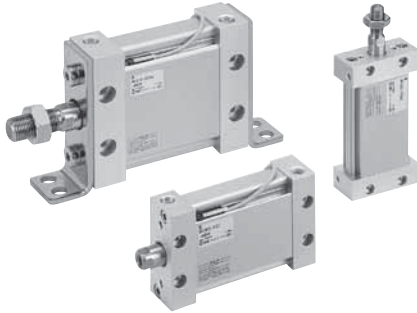

Bore size (mm)	25	32	40	50	63
Action	Double acting, Single rod				
Fluid	Air				
Proof pressure	1.05 MPa				
Maximum operating pressure	0.7 MPa				
Minimum operating pressure	0.05 MPa				
Ambient and fluid temperature	-10 to 60°C				
Lubrication	Not required (Non-lube)				
Piston speed	50 to 500 mm/s				
Stroke length tolerance	$\begin{matrix} +1.4 \\ 0 \end{matrix}$				
Cushion	Rubber bumper				
Mounting	Foot, Rod flange, Head flange, Single clevis, Double clevis				
Rod end configuration	Rod end male thread, Rod end female thread				
Allowable rotational torque	0.25 N-m		0.55 N-m	1.25 N-m	2.0 N-m
Rod non-rotating accuracy	$\pm 1^\circ$	$\pm 0.8^\circ$	$\pm 0.5^\circ$		

Standard Stroke

Size	Standard stroke (mm)	Maximum manufacturable stroke (mm)
25, 32, 40 50, 63	5, 10, 15, 20, 25, 30, 35, 40, 45, 50 75, 100, 125, 150, 175, 200, 250, 300	300

-  * Other intermediate strokes can be manufactured upon receipt of order. Please contact SMC.
** Strokes longer than 300 mm are not available.

Mounting Bracket/Part No.

Mounting bracket \ Size	25	32	40	50	63
Foot ^{Note 1)}	MU-L02	MU-L03	MU-L04	MU-L05	MU-L06
Flange	MU-F02	MU-F03	MU-F04	MU-F05	MU-F06
Single clevis	MU-C02	MU-C03	MU-C04	MU-C05	MU-C06
Double clevis ^{Note 3)}	MU-D02	MU-D03	MU-D04	MU-D05	MU-D06

-  Note 1) When ordering foot bracket, order 2 pieces per cylinder.
Note 2) Accessories for each mounting bracket are as follows.
Foot/Flange/Single clevis: Body mounting bolt
Double clevis: Clevis pin, Type C retaining ring for axis, Body mounting bolt
Note 3) Clevis pin and retaining ring are shipped together with double clevis.
Note 4) The tightening torque for body mounting bolts is shown in the below table.
Note 5) The application of a locking agent (Example: Loctite® 242) to body mounting bolts is recommended.

Recommended Tightening Torque for Mounting Bracket on Body

Bore size	Thread size	Tightening torque (N-m)
MU25	M5 x 0.8	4.9 to 5.9
MU32	M6 x 1	8.28 to 10.12
MU40	M8 x 1.25	19.8 to 24.2
MU50	M10 x 1.5	39.6 to 48.4
MU63	M12 x 1.75	68.4 to 83.6

Series MU

Theoretical Output

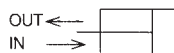

(N)

Size	Rod size (mm)	Operating direction	Piston area (mm ²)	Operating pressure (MPa)					
				0.2	0.3	0.4	0.5	0.6	0.7
25	12	OUT	491	98	147	196	246	295	344
		IN	378	76	113	151	189	227	265
32	14	OUT	804	161	241	322	402	482	563
		IN	650	130	195	260	325	390	455
40	16	OUT	1257	251	377	503	629	754	880
		IN	1056	211	317	422	528	634	739
50	20	OUT	1963	393	589	785	982	1178	1374
		IN	1649	330	495	660	824	989	1154
63	20	OUT	3117	623	935	1247	1559	1870	2182
		IN	2803	561	841	1121	1402	1682	1962

Note) Theoretical output (N) = Pressure (MPa) x Piston area (mm²)

Weight

(kg)

Size		25	32	40	50	63
Basic weight	Basic	0.17	0.27	0.39	0.75	1.16
	Foot	0.24	0.41	0.60	1.09	1.79
	Flange/Rod end, Head end	0.27	0.41	0.62	1.21	1.99
	Single clevis	0.23	0.39	0.61	1.15	1.84
	Double clevis (With pin)	0.24	0.43	0.65	1.22	1.92
Additional weight per each 50 mm of stroke		0.09	0.14	0.19	0.28	0.38
Mounting bracket weight	Single clevis (Double clevis pivot bracket)	0.06	0.12	0.22	0.40	0.68
	Double clevis (With pin) (Single clevis pivot bracket)	0.07	0.16	0.26	0.47	0.76
	Single knuckle joint	0.03	0.04	0.07	0.16	0.16
	Double knuckle joint (With pin)	0.05	0.09	0.14	0.29	0.29

Additional Weight

(g)

Bore size (mm)		25	32	40	50	63
Rod end male thread	Male thread	12	23	27	53	53
	Nut	8	10	17	32	32

Note) Weight of single clevis and double clevis includes 2 bolts for mounting bracket.

Calculation:

(Example) **MUL32-100DZ**

- Basic weight 0.41 (Foot, Equivalent to ø32)
- Additional weight 0.14/50 stroke
- Stroke 100 stroke

$$0.41 + 100/50 \times 0.14 = 0.69 \text{ kg}$$

Construction

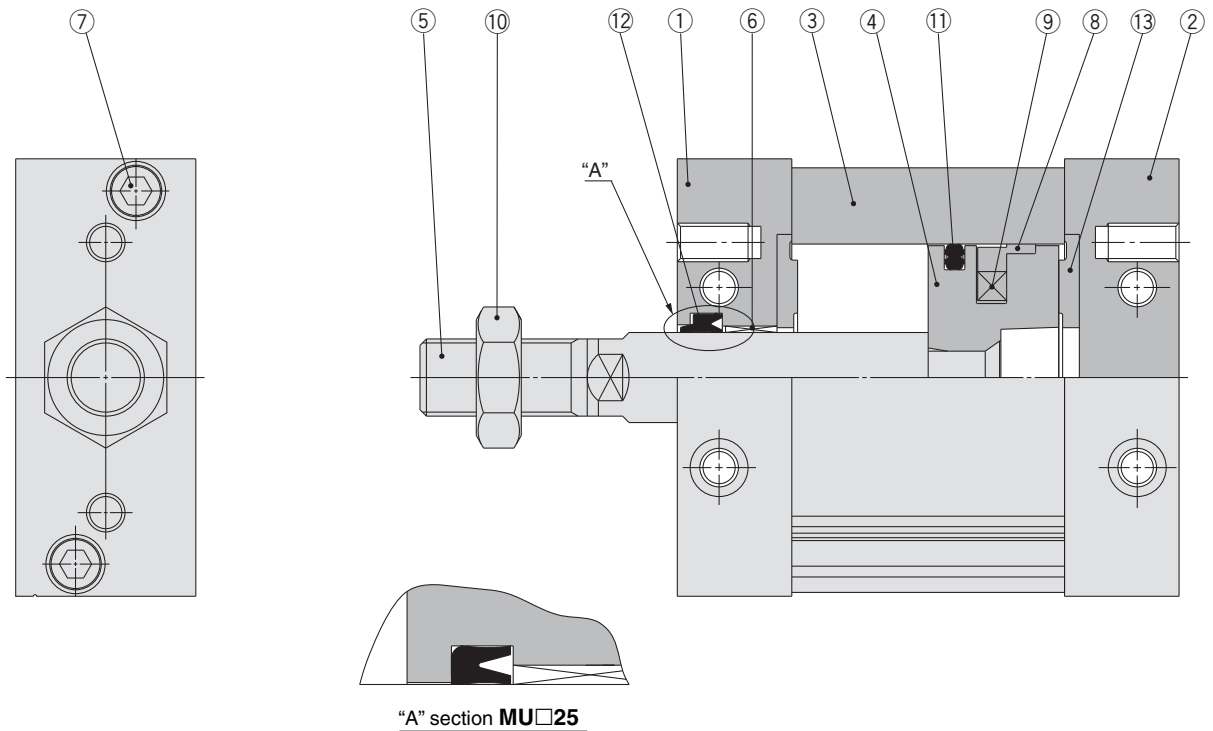

Component Parts

No.	Description	Material	Note
1	Rod cover	Aluminum alloy	Anodized
2	Head cover	Aluminum alloy	Anodized
3	Cylinder tube	Aluminum alloy	Hard anodized
4	Piston	Aluminum die-casted	Chromated
5	Piston rod	Carbon steel	Hard chrome plated
6	Bushing	Oil-impregnated sintered alloy	
7	Hexagon socket head bolt	Stainless steel	
8	Wear ring	Resin	
9	Magnet	—	Only built-in magnet type
10	Rod end nut	Rolled steel	Only attached to rod end male thread
11	Piston seal	NBR	
12	Rod seal	NBR	
13	Bumper	Urethane	

Replacement Parts/Seal Kit

Bore size (mm)	Kit no.	Contents
25	MUB25-PS	Set of nos. above ①, ⑫, ⑬
32	MUB32-PS	
40	MUB40-PS	
50	MUB50-PS	
63	MUB63-PS	

* Seal kit includes ① to ⑬. Order the seal kit, based on each bore size.

* Since the seal kit does not include a grease pack, order it separately.

Grease pack part no.: GR-S-010 (10 g)

Series MU

Basic: MUB

Rod end male thread

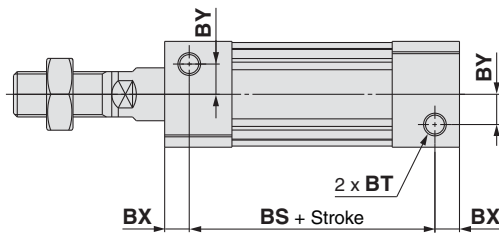
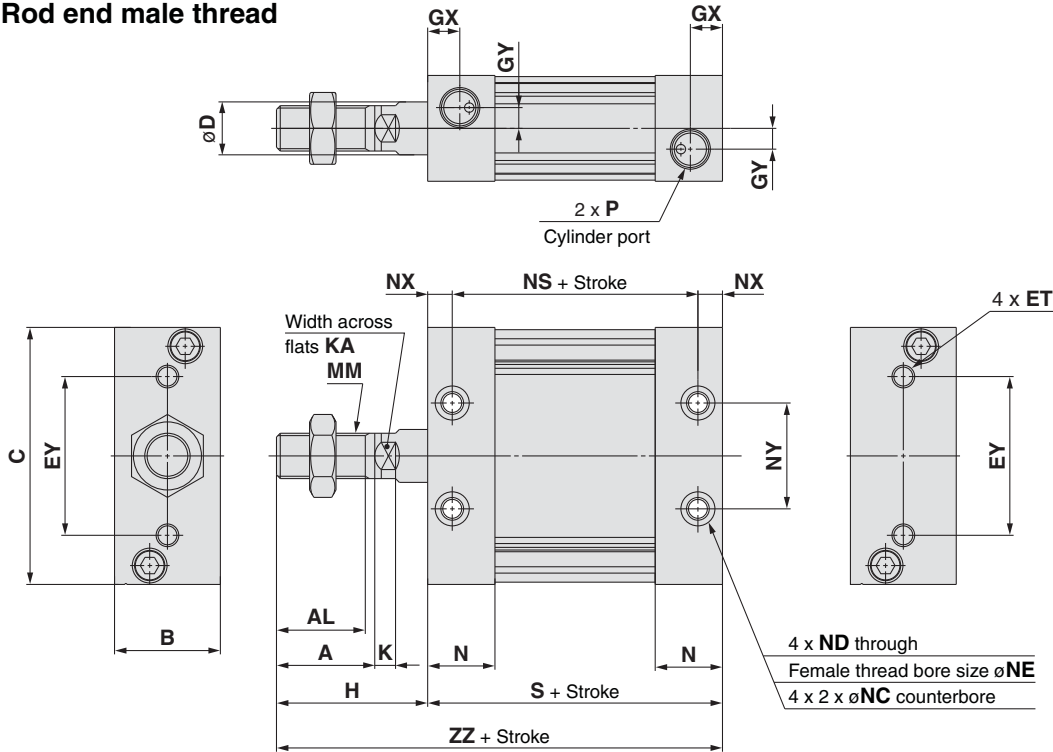

Rod end female thread

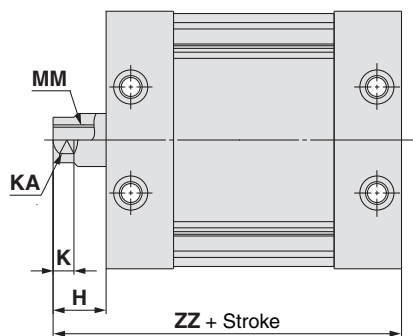

* Dimensions except mentioned on the right are the same as male thread type.
However, K and KA dimensions are the same as male thread type.

Rod end nut

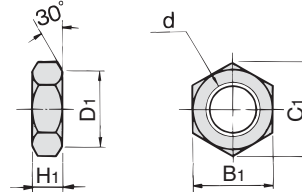

Part no.	Size	d	H1	B1	C1	D1
NT-03	25	M10 x 1.25	6	17	19.6	16.5
NT-MU03	32	M12 x 1.25	7	19	21.9	18
NT-04	40	M14 x 1.5	8	22	25.4	21
NT-05	50, 63	M18 x 1.5	11	27	31.2	26

* A nut is attached to the rod. Rod end nut material: Carbon steel end male thread as standard. Surface treatment: Nickel plated

Model	Stroke range (mm)	A	AL	B	BS	BT	BX	BY	C	D	ET	EY	GX	GY	H	K	KA
MUB25	5 to 300	22	19.5	24	37	M5 x 0.8 depth 7.5	9	7	54	12	M5 x 0.8 depth 11	26	10	5	36	5.5	10
MUB32	5 to 300	26	23.5	28	45	M6 x 1 depth 12	6.5	8	68	14	M6 x 1 depth 11	42	8.5	5.5	40	5.5	12
MUB40	5 to 300	30	27	32	44	M8 x 1.25 depth 13	8	9	86	16	M8 x 1.25 depth 11	54	9	7	45	6	14
MUB50	5 to 300	35	32	39	54	M10 x 1.5 depth 14.5	10	9	104	20	M10 x 1.5 depth 15	64	11.5	8	53	7	18
MUB63	5 to 300	35	32	50	53	M12 x 1.75 depth 18	11	12	124	20	M12 x 1.75 depth 15	72	11.5	10	56	7	18

(mm)

Model	MM	N	NC	ND	NE	NS	NX	NY	P			S	ZZ
									—	TN	TF		
MUB25	M10 x 1.25	16.5	7.5 depth 4.5	M5 x 0.8	4.3	43	6	26	M5 x 0.8	—	—	55	91
MUB32	M12 x 1.25	18	9 depth 5.5	M6 x 1	5.1	45	6.5	28	Rc1/8	NPT1/8	G1/8	58	98
MUB40	M14 x 1.5	18.5	10.5 depth 6.5	M8 x 1.25	6.9	44	8	36	Rc1/8	NPT1/8	G1/8	60	105
MUB50	M18 x 1.5	24	13.5 depth 8.5	M10 x 1.5	8.7	54	10	42	Rc1/4	NPT1/4	G1/4	74	127
MUB63	M18 x 1.5	24	17 depth 10.5	M12 x 1.75	10.5	53	11	46	Rc1/4	NPT1/4	G1/4	75	131

Rod End Female Thread (mm)

Model	H	MM	ZZ
MUB25	14	M6 x 1 depth 12	69
MUB32	14	M8 x 1.25 depth 13	72
MUB40	15	M8 x 1.25 depth 13	75
MUB50	18	M10 x 1.5 depth 15	92
MUB63	21	M10 x 1.5 depth 15	96

* The position of the 4 flats of the piston rod is $\pm 3^\circ$ in relation to the cylinder side surface.

Dimensions with Mounting Bracket

Foot

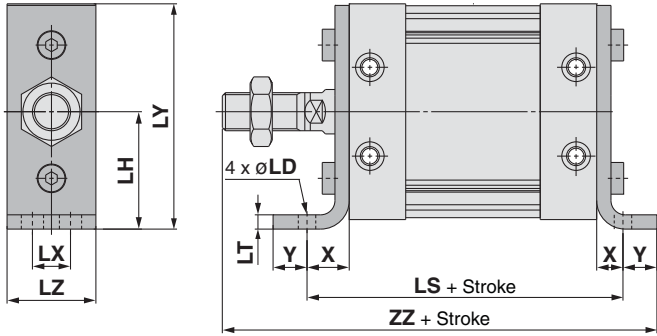

Model	LD	LH	LS	LT	LX	LY	LZ	X	Y	ZZ
MUL25	5.5	29	79	3.2	11	56	23	12	6	109
MUL32	6.6	37	90	4.5	12	71	27	16	8	122
MUL40	9	46	96	4.5	15	89	31	18	10	133
MUL50	11	57	116	5	18	109	37	21	11	159
MUL63	13.5	67	123	6	22	129	48	24	14	169

Foot bracket material: Rolled steel
Surface treatment: Nickel plated

Rod flange

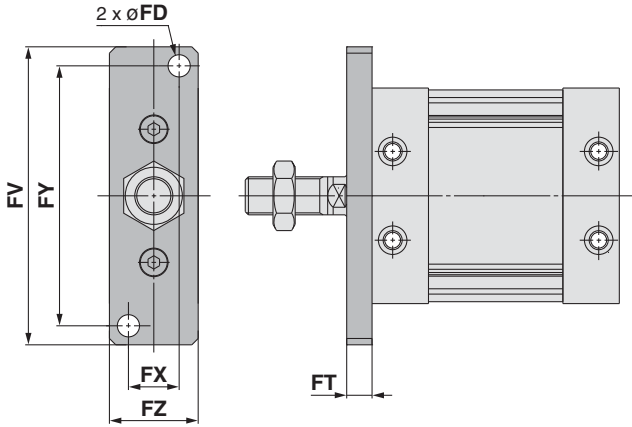

Head flange

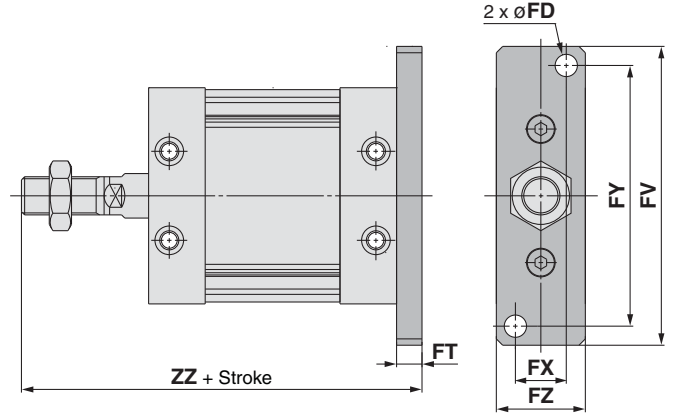

Model	FD	FT	FV	FX	FY	FZ	ZZ
MUF25, MUG25	5.5	8	76	14	66	24	99
MUF32, MUG32	7	8	94	16	82	28	106
MUF40, MUG40	9	9	118	18	102	32	114
MUF50, MUG50	11	12	144	22	126	39	139
MUF63, MUG63	13	14	168	30	148	50	145

Flange bracket material: Carbon steel
Surface treatment: Nickel plated

**Single clevis
Double clevis**

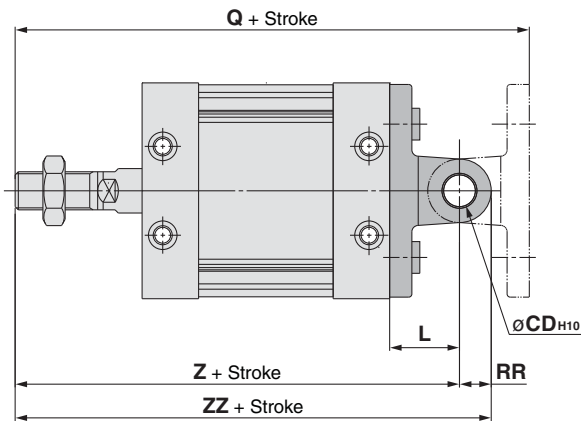

Single clevis

Double clevis

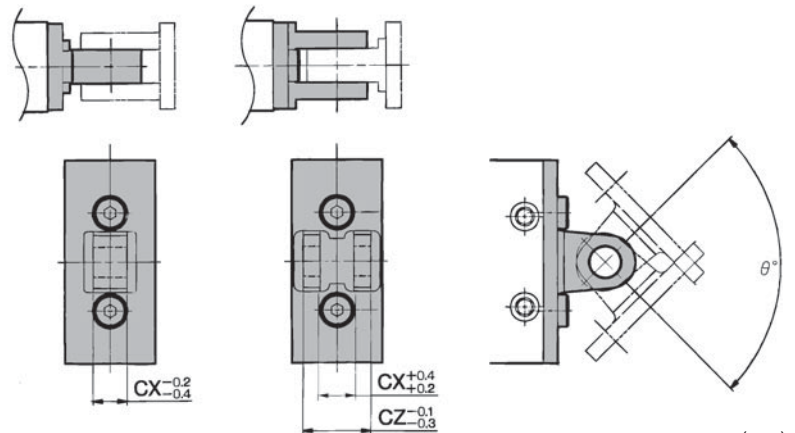

Model	CDH10	CX	CZ	L	Q	RR	Z	ZZ	Rotation range (θ°)
MUC25, MUD25	8 ^{+0.058} ₀	9	18	17	125	8	108	116	100
MUC32, MUD32	10 ^{+0.058} ₀	11	22	22	142	10	120	130	90
MUC40, MUD40	10 ^{+0.058} ₀	13	26	27	159	10	132	142	80
MUC50, MUD50	14 ^{+0.070} ₀	16	32	32	191	14	159	173	80
MUC63, MUD63	14 ^{+0.070} ₀	16	32	38	207	16	169	185	80

Clevis pin and retaining ring are shipped together with double clevis.

Single/Double clevis material: Cast iron
Surface treatment: Painted

Plate Cylinder: Double Acting, Double Rod Series *MUW*

ø25, ø32, ø40, ø50, ø63

How to Order

MUW B 25 [] - 30 D M Z

With auto switch MDUW B 25 [] - 30 D M Z - M9BW S

With auto switch (Built-in magnet)

Double rod

Mounting

B	Basic
L	Foot
F	Rod flange

* Brackets are shipped together, (but not assembled).

Size

25	Equiv. ø25 piston area
32	Equiv. ø32 piston area
40	Equiv. ø40 piston area
50	Equiv. ø50 piston area
63	Equiv. ø63 piston area

Port thread type

Nil	M thread	ø25
	Rc	
TN	NPT	ø32, ø40
TF	G	ø50, ø63

Number of auto switches

Nil	2 pcs.
S	1 pc.
n	"n" pcs.

Auto switch

Nil	Without auto switch
-----	---------------------

* Refer to the below table for applicable auto switch models.

Rod end configuration

Nil	Rod end female thread
M	Rod end male thread

Action

D	Double acting
---	---------------

Cylinder stroke (mm)
Refer to "Standard Stroke" on page 8.

Built-in Magnet Cylinder Model
If a built-in magnet cylinder without an auto switch is required, there is no need to enter the symbol for the auto switch.
(Example) MDUWL32-30DZ

Applicable Auto Switches/Refer to Best Pneumatics No. 2 for further information on auto switches.

Type	Special function	Electrical entry	Indicator/light	Wiring (Output)	Load voltage		Auto switch model		Lead wire length (m)				Pre-wired connector	Applicable load	
					DC	AC	Perpendicular	In-line	0.5 (Nil)	1 (M)	3 (L)	5 (Z)			
Solid state auto switch	—	Grommet	Yes	3-wire (NPN)	24 V	5 V, 12 V	—	M9NV	M9N	●	●	●	○	○	Relay, PLC
				3-wire (PNP)				M9PV	M9P	●	●	●	○	○	
				2-wire	M9BV	M9B	●	●	●	○	○				
				3-wire (NPN)	M9NWV	M9NW	●	●	●	○	○				
	Diagnostic indication (2-color indication)			3-wire (PNP)	M9PWV	M9PW	●	●	●	○	○				
				2-wire	M9BWV	M9BW	●	●	●	○	○				
				3-wire (NPN)	M9NAV**	M9NA**	○	○	●	○	○				
				3-wire (PNP)	M9PAV**	M9PA**	○	○	●	○	○				
Water resistant (2-color indication)	2-wire	M9BAV**	M9BA**	○	○	●	○	○							
	2-wire (Non-polar)	—	P3DW ^{Note 2)}	●	—	●	●	○							
Reed auto switch	—	Grommet	None	3-wire (NPN equivalent)	24 V	5 V	100 V	A96V	A96	●	—	●	—	—	IC circuit
				2-wire				A93V	A93	●	—	●	—	—	—
				2-wire	A90V	A90	●	—	●	—	—	—	IC circuit		

* Lead wire length symbols: 0.5 m Nil (Example) M9NW * Solid state auto switches marked with "○" are produced upon receipt of order.

1 m M (Example) M9NWM
3 m L (Example) M9NWL
5 m Z (Example) M9NWZ

* For details about auto switches with pre-wired connector, refer to Best Pneumatics No. 2.

* Auto switches are shipped together, (but not assembled).

** The water resistant auto switch (D-M9□A/M9□AV) can be mounted, but the product itself is not designed to be water resistant.

Note 1) The D-M9□V/M9□WV/M9□AV/A9□V auto switches cannot be mounted on the ported surface with some cylinder strokes and sizes of fittings. This should be checked beforehand.

Note 2) The magnetic field resistant auto switch (D-P3DW□) is available only with ø40 to ø63 of the existing MU series. Refer to page 23 for the how-to-order.

Plate Cylinder: Double Acting, Double Rod *Series MUW*

Specifications

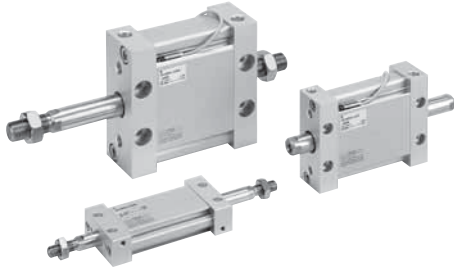

Bore size (mm)	25	32	40	50	63
Action	Double acting, Double rod				
Fluid	Air				
Proof pressure	1.05 MPa				
Maximum operating pressure	0.7 MPa				
Minimum operating pressure	0.05 MPa				
Ambient and fluid temperature	-10 to 60°C				
Lubrication	Not required (Non-lube)				
Piston speed	50 to 500 mm/s				
Stroke length tolerance	$+1.4$ 0				
Cushion	Rubber bumper				
Mounting	Foot, Rod flange				
Allowable rotational torque	0.25 N·m		0.55 N·m	1.25 N·m	2.0 N·m
Rod non-rotating accuracy	$\pm 1^\circ$	$\pm 0.8^\circ$	$\pm 0.5^\circ$		

Standard Stroke

Size	Standard stroke (mm)	Maximum manufacturable stroke (mm)
25, 32, 40	5, 10, 15, 20, 25, 30, 35, 40, 45, 50	300
50, 63	75, 100, 125, 150, 175, 200, 250, 300	

-  * Other intermediate strokes can be manufactured upon receipt of order. Please contact SMC.
 ** Strokes longer than 300 mm are not available.

Mounting Bracket/Part No.

Size	25	32	40	50	63
Mounting bracket					
Foot ^{Note 1)}	MU-L02	MU-L03	MU-L04	MU-L05	MU-L06
Rod flange	MU-F02	MU-F03	MU-F04	MU-F05	MU-F06

-  Note 1) When ordering foot bracket, order 2 pieces per cylinder.
 Note 2) Body mounting bolts are attached to the foot and rod flange.
 Note 3) The tightening torque for body mounting bolts is shown in the below table.
 Note 4) The application of a locking agent (Example: Loctite® 242) to body mounting bolts is recommended.

Recommended Tightening Torque for Mounting Bracket on Body

Bore size	Thread size	Tightening torque (N·m)
MU25	M5 x 0.8	4.9 to 5.9
MU32	M6 x 1	8.28 to 10.12
MU40	M8 x 1.25	19.8 to 24.2
MU50	M10 x 1.5	39.6 to 48.4
MU63	M12 x 1.75	68.4 to 83.6

Warning

When removing or installing a workpiece using rod end threads, do so while securing the width across flats on the removing or installing side. If applying a torque on the piston rod without securing the width across flats, connection threads inside are loosened, which may cause accidents or malfunctions.

Series MUW

Theoretical Output

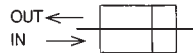

(N)

Size	Rod size (mm)	Operating direction	Piston area (mm ²)	Operating pressure (MPa)					
				0.2	0.3	0.4	0.5	0.6	0.7
25	12	IN/OUT	378	76	113	151	189	227	265
32	14	IN/OUT	650	130	195	260	325	390	455
40	16	IN/OUT	1056	211	317	422	528	634	739
50	20	IN/OUT	1649	330	495	660	824	989	1154
63	20	IN/OUT	2803	561	841	1121	1402	1682	1962

Note) Theoretical output (N) = Pressure (MPa) x Piston area (mm²)

Weight

(kg)

Size		25	32	40	50	63
Basic weight	Basic	0.18	0.31	0.46	0.87	1.34
	Foot	0.25	0.45	0.67	1.21	1.97
	Rod flange	0.28	0.45	0.69	1.33	2.17
Additional weight per each 50 mm of stroke		0.15	0.22	0.29	0.44	0.55
Mounting bracket weight	Single knuckle joint	0.03	0.04	0.07	0.16	0.16
	Double knuckle joint (With pin)	0.05	0.09	0.14	0.29	0.29

Additional Weight

(g)

Bore size (mm)		25	32	40	50	63
Rod end male thread	Male thread	24	46	54	106	106
	Nut	16	20	34	64	64

Calculation:

(Example) **MUWL32-100DZ**

- Basic weight 0.45 (Foot, Equivalent to ø32)
- Additional weight 0.22/50 stroke
- Stroke 100 stroke

$$0.45 + 100/50 \times 0.22 = 0.89 \text{ kg}$$

Construction

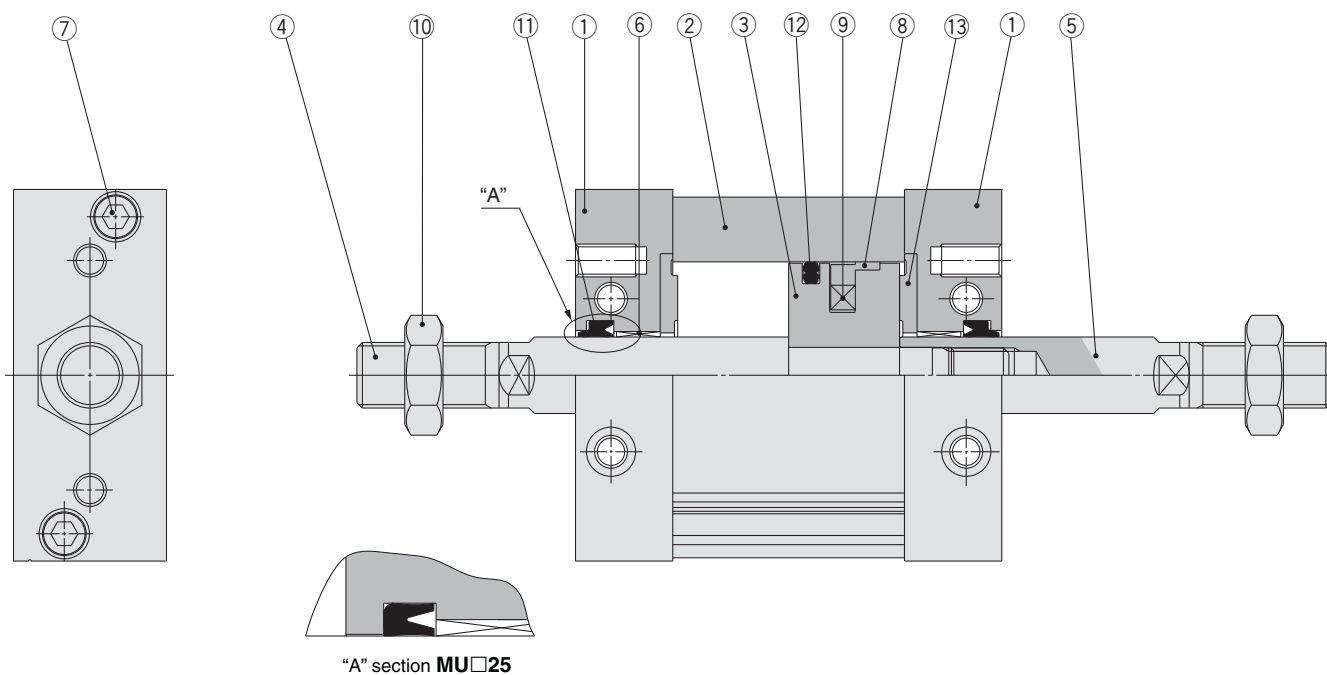

Component Parts

No.	Description	Material	Note
1	Rod cover	Aluminum alloy	Anodized
2	Cylinder tube	Aluminum alloy	Hard anodized
3	Piston	Aluminum alloy	Chromated
4	Piston rod A	Carbon steel	Hard chrome plated
5	Piston rod B	Carbon steel	Hard chrome plated
6	Bushing	Oil-impregnated sintered alloy	
7	Hexagon socket head bolt	Stainless steel	
8	Wear ring	Resin	
9	Magnet	—	Only built-in magnet type
10	Rod end nut	Rolled steel	Only attached to rod end male thread
11	Rod seal	NBR	
12	Piston seal	NBR	
13	Bumper	NBR	

Replacement Parts/Seal Kit

Bore size (mm)	Kit no.	Contents
25	MUW25-PS	Set of nos. above ①, ⑫, ⑬
32	MUW32-PS	
40	MUW40-PS	
50	MUW50-PS	
63	MUW63-PS	

* Seal kit includes ① to ⑬. Order the seal kit, based on each bore size.

* Since the seal kit does not include a grease pack, order it separately.

Grease pack part no.: GR-S-010 (10 g)

Series MUW

Basic: MUWB

Rod end male thread

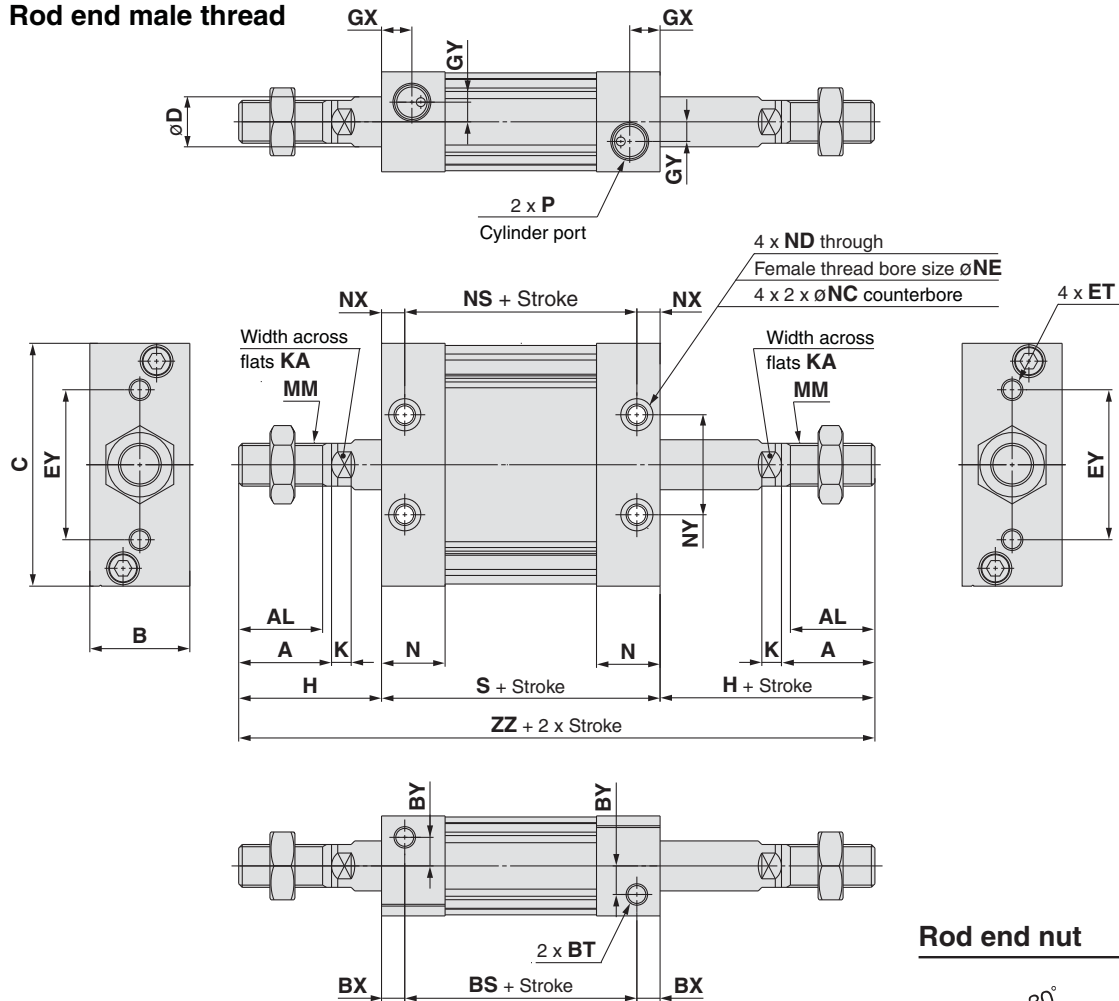

Rod end female thread

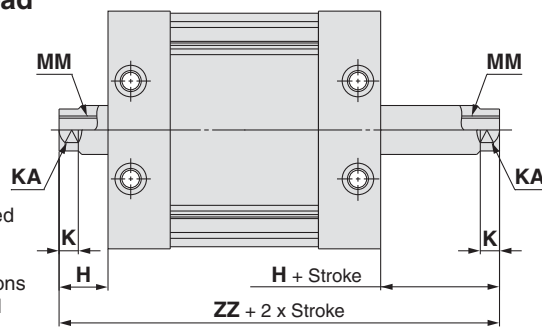

* Dimensions except mentioned on the right are the same as male thread type. However, K and KA dimensions are the same as male thread type.

Rod end nut

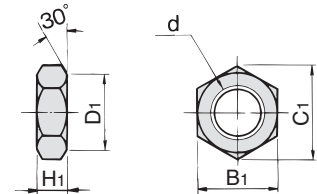

Part no.	Size	d	H ₁	B ₁	C ₁	D ₁
NT-03	25	M10 x 1.25	6	17	19.6	16.5
NT-MU03	32	M12 x 1.25	7	19	21.9	18
NT-04	40	M14 x 1.5	8	22	25.4	21
NT-05	50, 63	M18 x 1.5	11	27	31.2	26

* A nut is attached to the rod end male thread as standard. Rod end nut material: Carbon steel. Surface treatment: Nickel plated standard. (2 pieces for double rod type)

Model	Stroke range (mm)	A	AL	B	BS	BT	BX	BY	C	D	ET	EY	GX	GY	H	K	KA
MUWB25	5 to 300	22	19.5	24	37	M5 x 0.8 depth 7.5	9	7	54	12	M5 x 0.8 depth 11	26	10	5	36	5.5	10
MUWB32	5 to 300	26	23.5	28	45	M6 x 1 depth 12	6.5	8	68	14	M6 x 1 depth 11	42	8.5	5.5	40	5.5	12
MUWB40	5 to 300	30	27	32	44	M8 x 1.25 depth 13	8	9	86	16	M8 x 1.25 depth 11	54	9	7	45	6	14
MUWB50	5 to 300	35	32	39	54	M10 x 1.5 depth 14.5	10	9	104	20	M10 x 1.5 depth 15	64	11.5	8	53	7	18
MUWB63	5 to 300	35	32	50	53	M12 x 1.75 depth 18	11	12	124	20	M12 x 1.75 depth 15	72	11.5	10	56	7	18

Model	MM	N	NC	ND	NE	NS	NX	NY	P			S	ZZ
									—	TN	TF		
MUWB25	M10 x 1.25	16.5	7.5 depth 4.5	M5 x 0.8	4.3	43	6	26	M5 x 0.8	—	—	55	127
MUWB32	M12 x 1.25	18	9 depth 5.5	M6 x 1	5.1	45	6.5	28	Rc1/8	NPT1/8	G1/8	58	138
MUWB40	M14 x 1.5	18.5	10.5 depth 6.5	M8 x 1.25	6.9	44	8	36	Rc1/8	NPT1/8	G1/8	60	150
MUWB50	M18 x 1.5	24	13.5 depth 8.5	M10 x 1.5	8.7	54	10	42	Rc1/4	NPT1/4	G1/4	74	180
MUWB63	M18 x 1.5	24	17 depth 10.5	M12 x 1.75	10.5	53	11	46	Rc1/4	NPT1/4	G1/4	75	187

Rod End Female Thread (mm)

Model	H	MM	ZZ
MUWB25	14	M6 x 1 depth 12	83
MUWB32	14	M8 x 1.25 depth 13	86
MUWB40	15	M8 x 1.25 depth 13	90
MUWB50	18	M10 x 1.5 depth 15	110
MUWB63	21	M10 x 1.5 depth 15	117

* The position of the 4 flats of the piston rod is different from the above drawing. Position of the 4 flats of the piston rod for double rod type is not the same.

Dimensions with Mounting Bracket

Foot

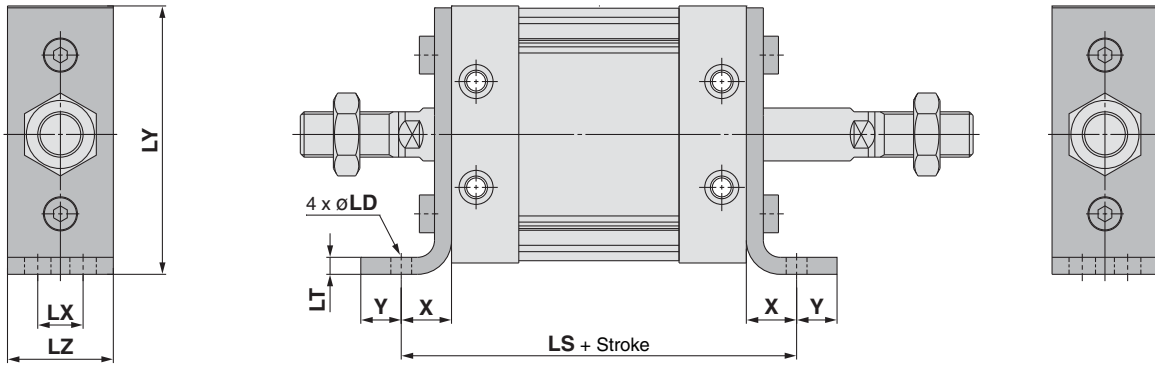

Model	LD	LH	LS	LT	LX	LY	LZ	X	Y
MUWL25	5.5	29	79	3.2	11	56	23	12	6
MUWL32	6.6	37	90	4.5	12	71	27	16	8
MUWL40	9	46	96	4.5	15	89	31	18	10
MUWL50	11	57	116	5	18	109	37	21	11
MUWL63	13.5	67	123	6	22	129	48	24	14

(mm)
Foot bracket material: Rolled steel
Surface treatment: Nickel plated

Rod flange

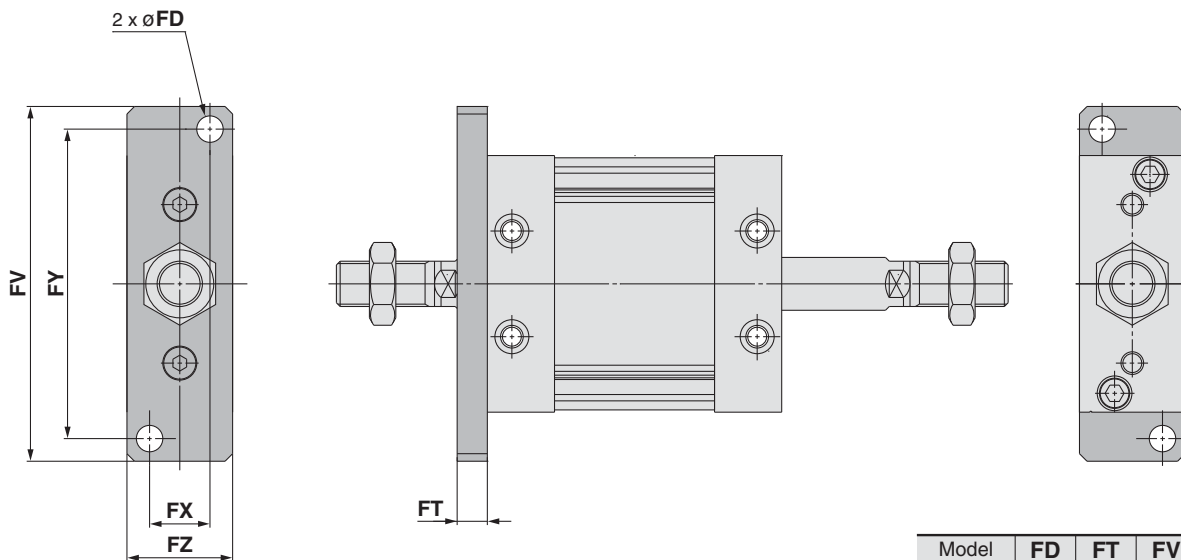

Model	FD	FT	FV	FX	FY	FZ
MUWF25	5.5	8	76	14	66	24
MUWF32	7	8	94	16	82	28
MUWF40	9	9	118	18	102	32
MUWF50	11	12	144	22	126	39
MUWF63	13	14	168	30	148	50

(mm)
Rod flange bracket material: Carbon steel
Surface treatment: Nickel plated

Plate Cylinder: Single Acting, Spring Return/Extend

Series MU

ø25, ø32, ø40, ø50, ø63

How to Order

MU B 25 [] - 10 S M Z

With auto switch MDU B 25 [] - 10 S M Z - M9BW S

With auto switch (Built-in magnet)

Mounting

B	Basic
L	Foot
F	Rod flange
G	Head flange
C	Single clevis
D	Double clevis

* Brackets are shipped together, (but not assembled).

Size

25	Equiv. ø25 piston area
32	Equiv. ø32 piston area
40	Equiv. ø40 piston area
50	Equiv. ø50 piston area
63	Equiv. ø63 piston area

Port thread type

Nil	M thread	ø25
	Rc	
TN	NPT	ø32, ø40
	G	ø50, ø63
TF	G	

Number of auto switches

Nil	2 pcs.
S	1 pc.
n	"n" pcs.

Auto switch

Nil	Without auto switch
------------	---------------------

* Refer to the below table for applicable auto switch models.

Rod end configuration

Nil	Rod end female thread
M	Rod end male thread

Action

S	Single acting, Spring return
T	Single acting, Spring extend

Built-in Magnet Cylinder Model

If a built-in magnet cylinder without an auto switch is required, there is no need to enter the symbol for the auto switch. (Example) MDUL32-10TZ

Rod end configuration

Cylinder standard stroke (mm)

ø25, ø32	5, 10
ø40, ø50, ø63	5, 10, 15, 20

Applicable Auto Switches/Refer to Best Pneumatics No. 2 for further information on auto switches.

Type	Special function	Electrical entry	Indicator/light	Wiring (Output)	Load voltage		Auto switch model		Lead wire length (m)				Pre-wired connector	Applicable load		
					DC	AC	Perpendicular	In-line	0.5 (Nil)	1 (M)	3 (L)	5 (Z)				
Solid state auto switch	—	Grommet	Yes	3-wire (NPN)	24 V	5 V, 12 V	—	M9NV	M9N	●	●	●	○	○	Relay, PLC	
				3-wire (PNP)				M9PV	M9P	●	●	●	○	○		
				2-wire	12 V	M9BV	M9B	●	●	●	○	○				
				3-wire (NPN)	5 V, 12 V	M9NWV	M9NW	●	●	●	○	○				
	3-wire (PNP)			12 V	M9PWV	M9PW	●	●	●	○	○					
	2-wire			12 V	M9BWV	M9BW	●	●	●	○	○					
	3-wire (NPN)			5 V, 12 V	M9NAV**	M9NA**	○	○	●	○	○					
	3-wire (PNP)			12 V	M9PAV**	M9PA**	○	○	●	○	○					
Water resistant (2-color indication)	2-wire	12 V	M9BAV**	M9BA**	○	○	●	○	○							
Magnetic field resistant (2-color indication)		—	—	P3DW Note 2)	●	—	●	●	○							
Reed auto switch	—	Grommet	Yes	3-wire (NPN equivalent)	—	5 V	—	A96V	A96	●	—	●	—	—	IC circuit	—
				2-wire	24 V	12 V	100 V	A93V	A93	●	—	●	—	—	—	Relay, PLC
					100 V or less	A90V	A90	●	—	●	—	—	—	—	IC circuit	

* Lead wire length symbols: 0.5 m Nil (Example) M9NW
1 m M (Example) M9NWM
3 m L (Example) M9NWL
5 m Z (Example) M9NWZ

* Solid state auto switches marked with "○" are produced upon receipt of order.

* For details about auto switches with pre-wired connector, refer to Best Pneumatics No. 2.

* Auto switches are shipped together, (but not assembled).

** The water resistant auto switch (D-M9□V/M9□WV/M9□AV/A9□V) can be mounted, but the product itself is not designed to be water resistant.

Note 1) The D-M9□V/M9□WV/M9□AV/A9□V auto switches cannot be mounted on the ported surface with some cylinder strokes and sizes of fittings. This should be checked beforehand.

Note 2) The magnetic field resistant auto switch (D-P3DW□) is available only with ø40 to ø63 of the existing MU series. Refer to page 23 for the how-to-order.

Specifications

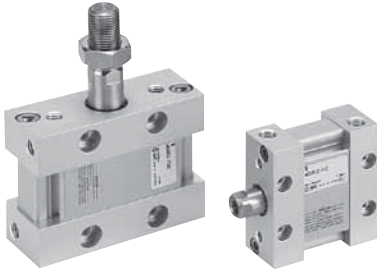

Bore size (mm)	25	32	40	50	63
Action	Single acting, Spring return/Spring extend				
Fluid	Air				
Proof pressure	1.05 MPa				
Maximum operating pressure	0.7 MPa				
Minimum operating pressure	0.18 MPa				
Ambient and fluid temperature	-10 to 60°C				
Lubrication	Not required (Non-lube)				
Piston speed	50 to 500 mm/s				
Stroke length tolerance	$+1.4$ 0				
Cushion	Rubber bumper				
Mounting	Foot, Rod flange, Head flange, Single clevis, Double clevis				
Allowable rotational torque	0.25 N·m		0.55 N·m	1.25 N·m	2.0 N·m
Rod non-rotating accuracy	$\pm 1^\circ$	$\pm 0.8^\circ$	$\pm 0.5^\circ$		

Standard Stroke

Action	Size (mm)				
	25	32	40	50	63
Spring return/Spring extend	5, 10		5, 10, 15, 20		

* For strokes other than above, please contact SMC.

Mounting Bracket/Part No.

Mounting bracket	25	32	40	50	63
Foot <small>Note 1)</small>	MU-L02	MU-L03	MU-L04	MU-L05	MU-L06
Flange	MU-F02	MU-F03	MU-F04	MU-F05	MU-F06
Single clevis	MU-C02	MU-C03	MU-C04	MU-C05	MU-C06
Double clevis <small>Note 3)</small>	MU-D02	MU-D03	MU-D04	MU-D05	MU-D06



Note 1) When ordering foot bracket, order 2 pieces per cylinder.

Note 2) Accessories for each mounting bracket are as follows.

Foot/Flange/Single clevis: Body mounting bolt

Double clevis: Clevis pin, Type C retaining ring for axis, Body mounting bolt

Note 3) Clevis pin and retaining ring are shipped together with double clevis.

Note 4) The tightening torque for body mounting bolts is shown in the below table.

Note 5) The application of a locking agent (Example: Loctite® 242) to body mounting bolts is recommended.

Recommended Tightening Torque for Mounting Bracket on Body

Bore size	Thread size	Tightening torque (N·m)
MU25	M5 x 0.8	4.9 to 5.9
MU32	M6 x 1	8.28 to 10.12
MU40	M8 x 1.25	19.8 to 24.2
MU50	M10 x 1.5	39.6 to 48.4
MU63	M12 x 1.75	68.4 to 83.6

Series MU

Theoretical Output



(N)

Action	Size	Rod size (mm)	Operating direction	Piston area (mm ²)	Operating pressure (MPa)						Spring reaction force	
					0.2	0.3	0.4	0.5	0.6	0.7	Secondary	Primary
Spring return	25	12	OUT	491	68	117	166	216	265	314	30	15
	32	14	OUT	804	119	199	280	360	440	521	42	24
	40	16	OUT	1257	195	321	447	573	698	824	56	30
	50	20	OUT	1963	346	542	738	935	1131	1327	76	47
	63	20	OUT	3117	510	822	1134	1446	1757	2069	113	61
Spring extend	25	12	IN	378	46	83	121	159	197	235	30	15
	32	14	IN	650	88	153	218	283	348	413	42	24
	40	16	IN	1056	155	261	366	472	578	683	56	30
	50	20	IN	1649	283	448	613	777	942	1107	76	47
	63	20	IN	2803	448	728	1008	1289	1569	1849	113	61

Note) Theoretical output (N) = Pressure (MPa) x Piston area (mm²)

Weight

(kg)

Size		25	32	40	50	63
Basic weight	5 stroke	0.21	0.26	0.55	1.02	1.51
	10 stroke	0.22	0.34	0.58	1.05	1.56
	15 stroke	—	—	0.60	1.08	1.60
	20 stroke	—	—	0.62	1.12	1.65
Mounting bracket weight	Foot	0.07	0.14	0.21	0.34	0.63
	Flange/Rod end, Head end	0.10	0.14	0.23	0.46	0.83
	Single clevis	0.06	0.12	0.22	0.40	0.68
	Double clevis (With pin)	0.07	0.16	0.26	0.47	0.76
Accessory bracket weight	Single clevis (Double clevis pivot bracket)	0.06	0.12	0.22	0.40	0.68
	Double clevis (With pin) (Single clevis pivot bracket)	0.07	0.16	0.26	0.47	0.76
	Single knuckle joint	0.03	0.04	0.07	0.16	0.16
	Double knuckle joint (With pin)	0.05	0.09	0.14	0.29	0.29

Additional Weight

(g)

Bore size (mm)		25	32	40	50	63
Rod end male thread	Male thread	12	23	27	53	53
	Nut	8	10	17	32	32

Note) Weight of single clevis and double clevis includes 2 bolts for mounting bracket.

Calculation:

(Example 1) **MUB40-15S(T)Z**

- Basic weight 0.60 kg

(Example 2) **MUC50-5S(T)Z**

- Basic weight 1.02
- Mounting bracket weight 0.40

$$1.02 + 0.40 = 1.42 \text{ kg}$$

Construction

Spring return

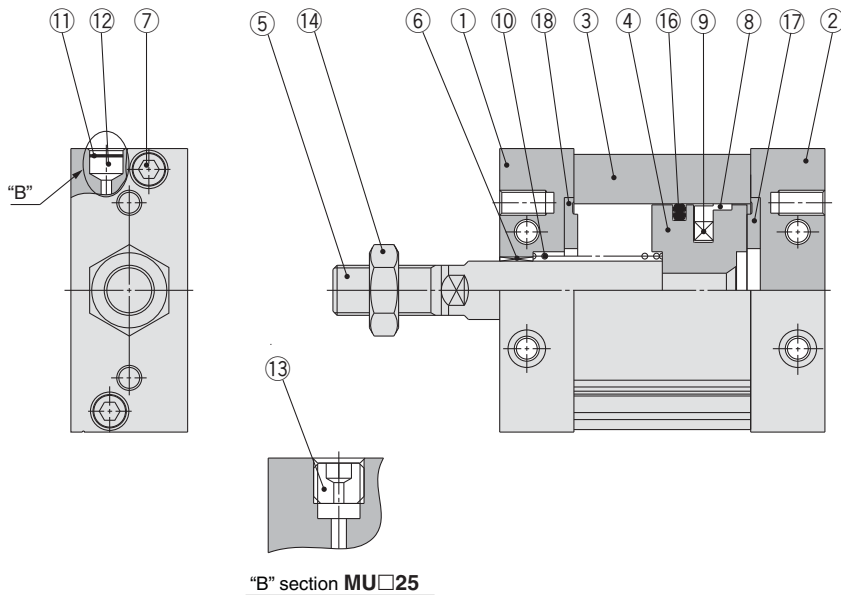

"B" section MU□25

Spring extend

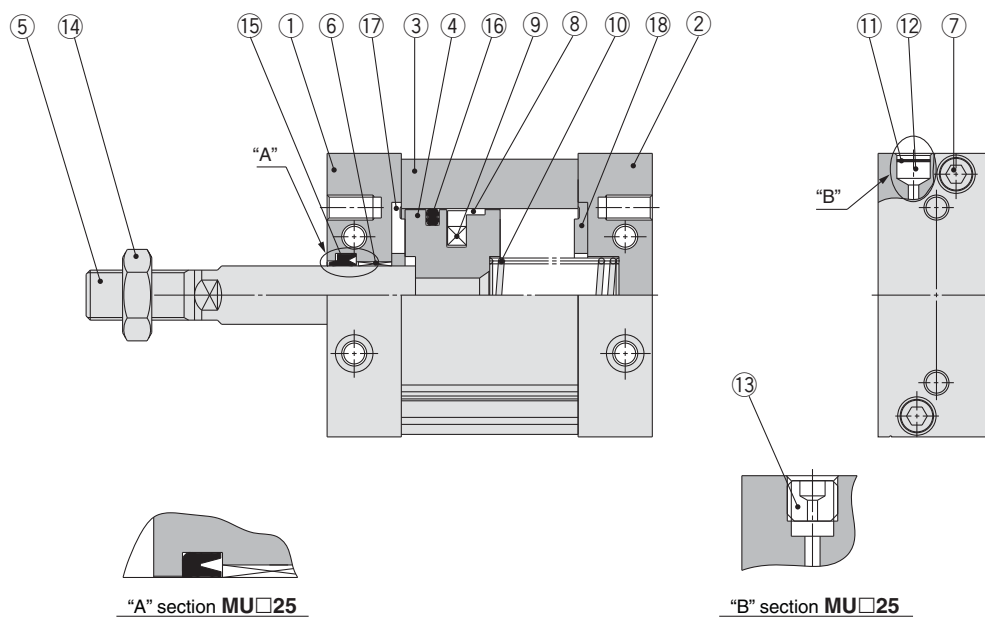

"A" section MU□25

"B" section MU□25

Component Parts

No.	Description	Material	Note
1	Rod cover	Aluminum alloy	Anodized
2	Head cover	Aluminum alloy	Anodized
3	Cylinder tube	Aluminum alloy	Hard anodized
4	Piston	Aluminum alloy	Chromated
5	Piston rod	Carbon steel	Hard chrome plated
6	Bushing	Oil-impregnated sintered alloy	
7	Hexagon socket head bolt	Stainless steel	
8	Wear ring	Resin	
9	Magnet	—	Only built-in magnet type
10	Return spring	Steel wire	Zinc chromated
11	Element	Bronze	
12	Retaining ring	Spring steel	
13	Plug	Chromium molybdenum steel	
14	Rod end nut	Rolled steel	Only attached to rod end male thread
15	Rod seal	NBR	
16	Piston seal	NBR	
17	Bumper	Urethane	
18	Bumper B	Urethane	

Replacement Parts/Seal Kit

Bore size (mm)	Kit no.		Contents
	Spring return	Spring extend	
25	MU25S-PS	MU25T-PS	For spring return type: ⑬, ⑰, ⑱ as a set For spring extend type: ⑮, ⑯, ⑰, ⑱ as a set
32	MU32S-PS	MU32T-PS	
40	MU40S-PS	MU40T-PS	
50	MU50S-PS	MU50T-PS	
63	MU63S-PS	MU63T-PS	

* Seal kit includes ⑮, ⑯, ⑰, ⑱ (excluding ⑮ for spring return type). Order them with a part number for each bore size.

* Since the seal kit does not include a grease pack, order it separately.

Grease pack part no.: GR-S-010 (10 g)

Series MU

Basic

Spring return

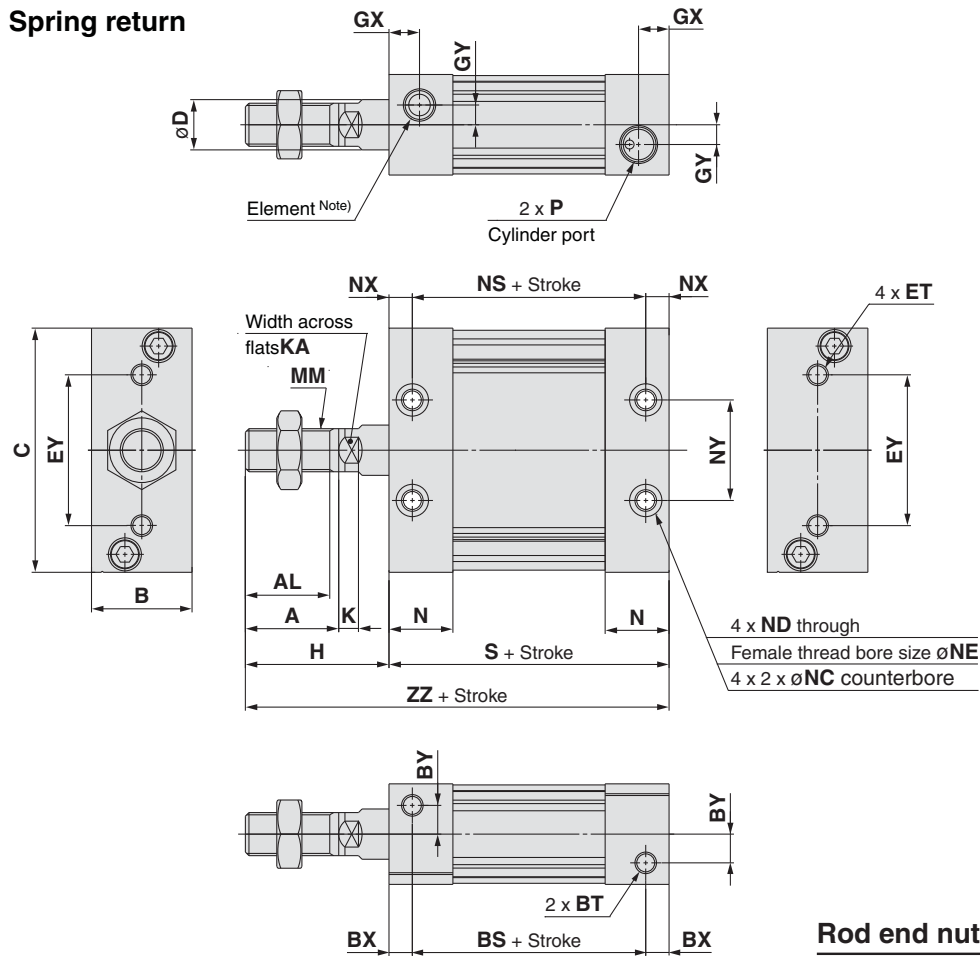

Rod end female thread

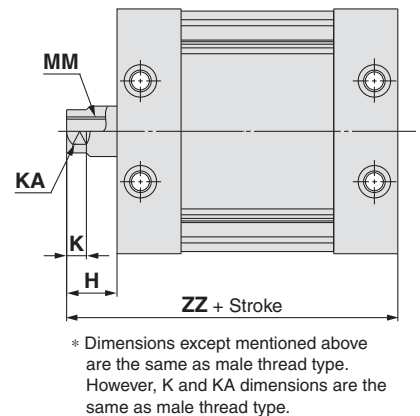

Spring extend

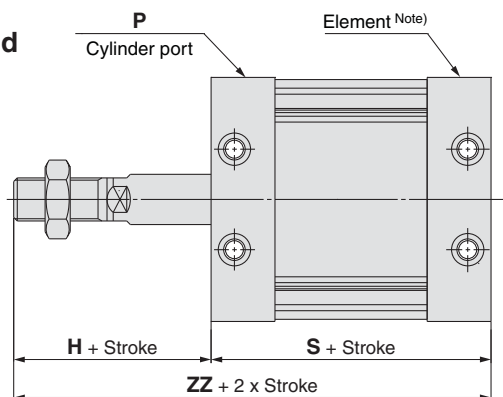

Note) Plugged for the MUB25

Rod end nut

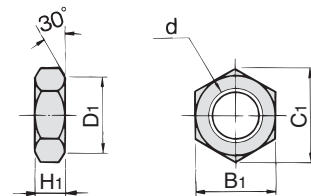

Part no.	Size	d	H1	B1	C1	D1
NT-03	25	M10 x 1.25	6	17	19.6	16.5
NT-MU03	32	M12 x 1.25	7	19	21.9	18
NT-04	40	M14 x 1.5	8	22	25.4	21
NT-05	50, 63	M18 x 1.5	11	27	31.2	26

* A nut is attached to the rod end male thread as standard.

Rod end nut material: Carbon steel
Surface treatment: Nickel plated

Model	Standard stroke (mm)	A	AL	B	BS	BT	BX	BY	C	D	ET	EY	GX	GY	H	K	KA
MUB25	5, 10	22	19.5	24	42	M5 x 0.8 depth 7.5	9	7	54	12	M5 x 0.8 depth 11	26	10	5	36	5.5	10
MUB32	5, 10	26	23.5	28	50	M6 x 1 depth 12	6.5	8	68	14	M6 x 1 depth 11	42	8.5	5.5	40	5.5	12
MUB40	5, 10, 15, 20	30	27	32	54	M8 x 1.25 depth 13	8	9	86	16	M8 x 1.25 depth 11	54	9	7	45	6	14
MUB50	5, 10, 15, 20	35	32	39	64	M10 x 1.5 depth 14.5	10	9	104	20	M10 x 1.5 depth 15	64	11.5	8	53	7	18
MUB63	5, 10, 15, 20	35	32	50	63	M12 x 1.75 depth 18	11	12	124	20	M12 x 1.75 depth 15	72	11.5	10	56	7	18

Model	MM	N	NC	ND	NE	NS	NX	NY	P			S	ZZ
									—	TN	TF		
MUB25	M10 x 1.25	16.5	7.5 depth 4.5	M5 x 0.8	4.3	48	6	26	M5 x 0.8	—	—	60	96
MUB32	M12 x 1.25	18	9 depth 5.5	M6 x 1	5.1	50	6.5	28	Rc1/8	NPT1/8	G1/8	63	103
MUB40	M14 x 1.5	18.5	10.5 depth 6.5	M8 x 1.25	6.9	54	8	36	Rc1/8	NPT1/8	G1/8	70	115
MUB50	M18 x 1.5	24	13.5 depth 8.5	M10 x 1.5	8.7	64	10	42	Rc1/4	NPT1/4	G1/4	84	137
MUB63	M18 x 1.5	24	17 depth 10.5	M12 x 1.75	10.5	63	11	46	Rc1/4	NPT1/4	G1/4	85	141

Rod End Female Thread (mm)			
Model	H	MM	ZZ
MUB25	14	M6 x 1 depth 12	74
MUB32	14	M8 x 1.25 depth 13	77
MUB40	15	M8 x 1.25 depth 13	85
MUB50	18	M10 x 1.5 depth 15	102
MUB63	21	M10 x 1.5 depth 15	106

* The position of the 4 flats of the piston rod is $\pm 3^\circ$ in relation to the cylinder side surface.

Dimensions with Mounting Bracket

Foot

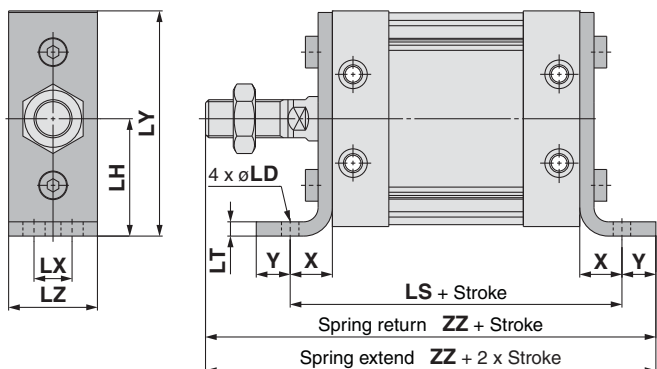

Model	LD	LH	LS	LT	LX	LY	LZ	X	Y	ZZ
MUL25	5.5	29	84	3.2	11	56	23	12	6	114
MUL32	6.6	37	95	4.5	12	71	27	16	8	127
MUL40	9	46	106	4.5	15	89	31	18	10	143
MUL50	11	57	126	5	18	109	37	21	11	169
MUL63	13.5	67	133	6	22	129	48	24	14	179

Foot bracket material: Rolled steel
Surface treatment: Nickel plated

Rod flange

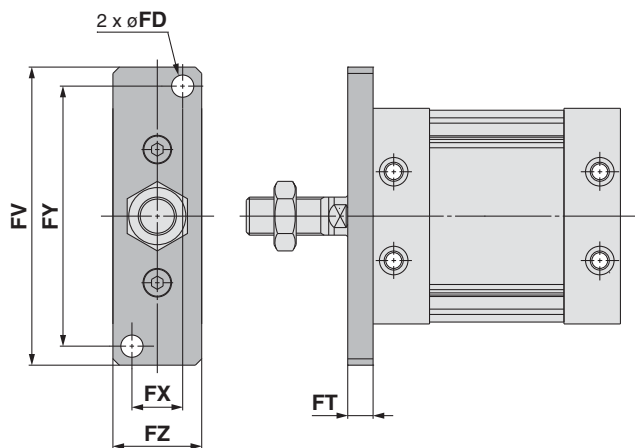

Head flange

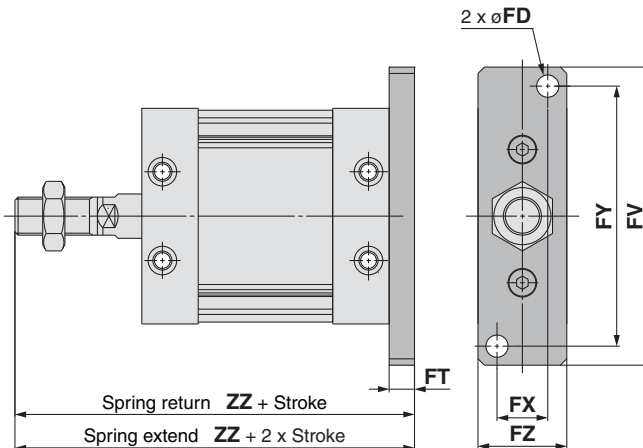

Model	FD	FT	FV	FX	FY	FZ	ZZ
MUF25, MUG25	5.5	8	76	14	66	24	104
MUF32, MUG32	7	8	94	16	82	28	111
MUF40, MUG40	9	9	118	18	102	32	124
MUF50, MUG50	11	12	144	22	126	39	149
MUF63, MUG63	13	14	168	30	148	50	155

Flange bracket material: Carbon steel
Surface treatment: Nickel plated

Single clevis Double clevis

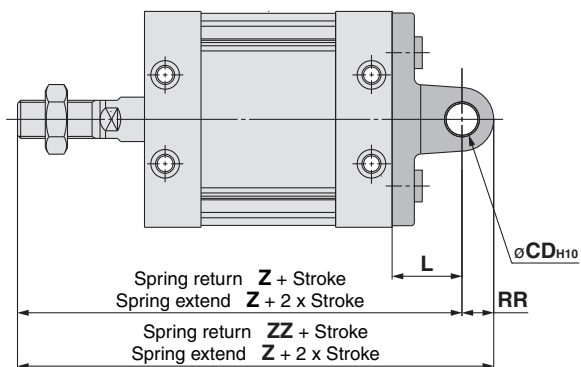

Single clevis

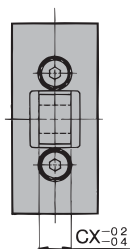

Double clevis

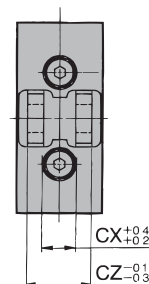

Model	CD _{H10}	CX	CZ	L	RR	Z	ZZ
MUC25, MUD25	$8^{+0.058}_0$	9	18	17	8	113	121
MUC32, MUD32	$10^{+0.058}_0$	11	22	22	10	125	135
MUC40, MUD40	$10^{+0.058}_0$	13	26	27	10	142	152
MUC50, MUD50	$14^{+0.070}_0$	16	32	32	14	169	183
MUC63, MUD63	$14^{+0.070}_0$	16	32	38	16	179	185

Clevis pin and retaining ring are shipped together with double clevis.

Single/Double clevis material: Cast iron
Surface treatment: Painted

Plate Cylinder

Series MU

Accessory Bracket Dimensions

Single Clevis (Double clevis pivot bracket)

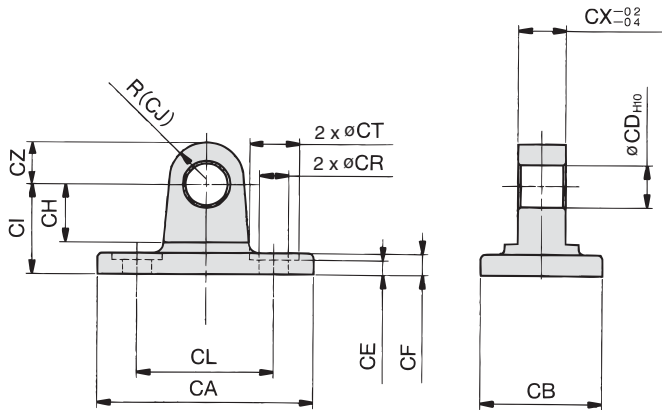

Part no.	Size	CA	CB	CDH10	CE	CF	CH	CI	CJ
MU-C02	25	53	23	8 ^{+0.058} ₀	3.5	4	11	17	7
MU-C03	32	67	27	10 ^{+0.058} ₀	3.5	7	13	22	10
MU-C04	40	85	31	10 ^{+0.058} ₀	3.5	10	13	27	10
MU-C05	50	103	37	14 ^{+0.070} ₀	5.5	12	17	32	14
MU-C06	63	122	48	14 ^{+0.070} ₀	6	14	19	38	16

Part no.	CL	CR	CT	CX	CZ
MU-C02	26	5.3	9.5	9	8
MU-C03	42	6.4	11	11	10
MU-C04	54	8.4	14	13	10
MU-C05	64	10.5	17	16	14
MU-C06	72	13	20	16	16

Material: Cast iron
Surface treatment: Painted

Double Clevis (Single clevis pivot bracket)

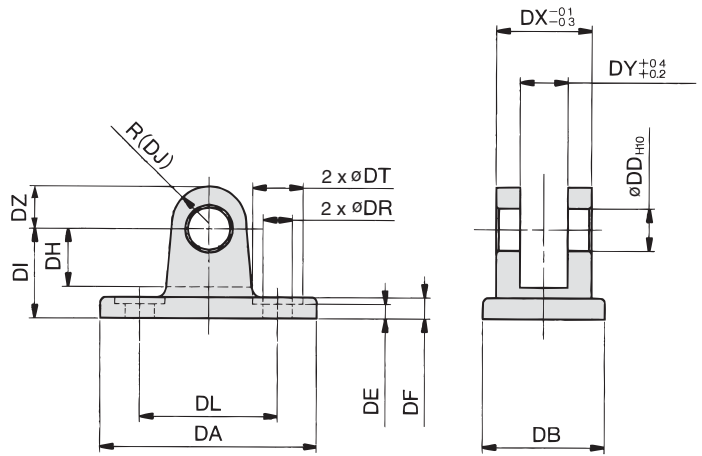

Part no.	Size	DA	DB	DDH10	DE	DF	DH	DI	DJ
MU-D02	25	53	23	8 ^{+0.058} ₀	3.5	4	11	17	7
MU-D03	32	67	27	10 ^{+0.058} ₀	3.5	7	13	22	10
MU-D04	40	85	31	10 ^{+0.058} ₀	3.5	10	13	27	10
MU-D05	50	103	37	14 ^{+0.070} ₀	5.5	12	17	32	14
MU-D06	63	122	48	14 ^{+0.070} ₀	6	14	19	38	16

Part no.	DL	DR	DT	DX	DY	DZ	Applicable pin
MU-D02	26	5.3	9.5	18	9	8	CD-MU02
MU-D03	42	6.4	11	22	11	10	CD-MU03
MU-D04	54	8.4	14	26	13	10	CD-MU04
MU-D05	64	10.5	17	32	16	14	CD-MU05
MU-D06	72	13	20	32	16	16	CD-MU05

Material: Cast iron
Surface treatment: Painted

Clevis pin and retaining ring are attached to double clevis.

Single Knuckle Joint

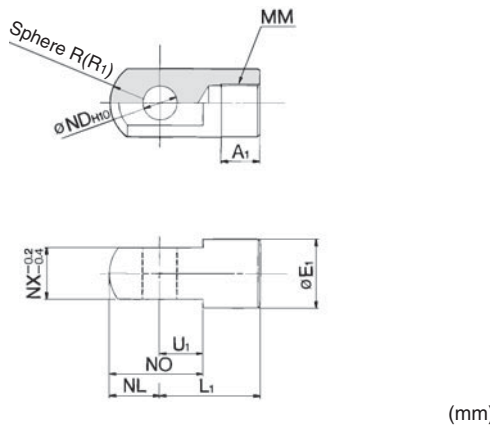

Part no.	Size	A1	E1	L1	MM
I-MU02	25	10.5	16	27	M10 x 1.25
I-MU03	32	12	18	31	M12 x 1.25
I-MU04	40	14	20	36	M14 x 1.5
I-MU05	50, 63	18	28	46	M18 x 1.5

Part no.	NDH10	NL	NO	NX	R1	U1
I-MU02	8 ^{+0.058} ₀	8.5	19.5	9	8.5	11
I-MU03	10 ^{+0.058} ₀	10	24	11	10	14
I-MU04	10 ^{+0.058} ₀	11	26	13	11	15
I-MU05	14 ^{+0.070} ₀	16	36	16	16	20

Material: Rolled steel
Surface treatment: Nickel plated

Double Knuckle Joint

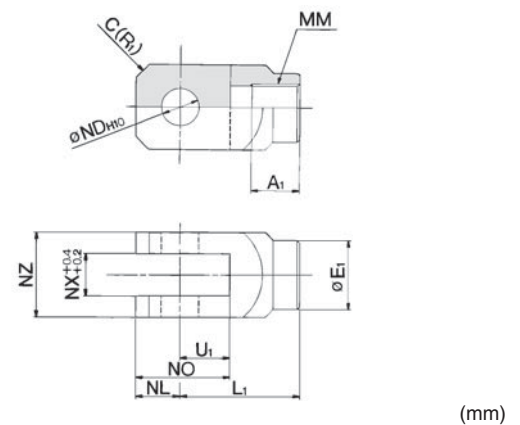

Part no.	Size	A1	E1	L1	MM	NDH10
Y-MU02	25	10.5	14	27	M10 x 1.25	8 ^{+0.058} ₀
Y-MU03	32	12	18	31	M12 x 1.25	10 ^{+0.058} ₀
Y-MU04	40	14	20	36	M14 x 1.5	10 ^{+0.058} ₀
Y-MU05	50, 63	18	28	46	M18 x 1.5	14 ^{+0.070} ₀

Part no.	NL	NO	NX	NZ	R1	U1	Applicable pin
Y-MU02	8	21	9	18	3	13	CD-MU02
Y-MU03	10	24	11	22	4	14	CD-MU03
Y-MU04	10	27	13	26	5	17	CD-MU04
Y-MU05	16	39	16	32	6	23	CD-MU05

* Knuckle pin and retaining ring are included.

Material: Rolled steel
Surface treatment: Nickel plated

Clevis Pin/Knuckle Pin

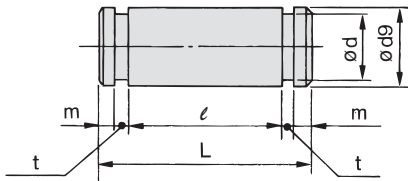

(mm)

Part no.	Size	Dd9	L	d	l	m	t	Retaining ring
CD-MU02	25	8 ^{-0.040} _{-0.076}	23	7.6	18.2	1.5	0.9	Type C8 for axis
CD-MU03	32	10 ^{-0.040} _{-0.076}	27	9.6	22.2	1.25	1.15	Type C10 for axis
CD-MU04	40	10 ^{-0.040} _{-0.076}	31	9.6	26.2	1.25	1.15	Type C10 for axis
CD-MU05	50, 63	14 ^{-0.050} _{-0.093}	38	13.4	32.2	1.75	1.15	Type C14 for axis

* These are provided as standard for double clevis and double knuckle joint.

Material: Carbon steel

** Type C retaining rings for axis are attached.

Series MU

Auto Switch Proper Mounting Position (Detection at stroke end) and Mounting Height

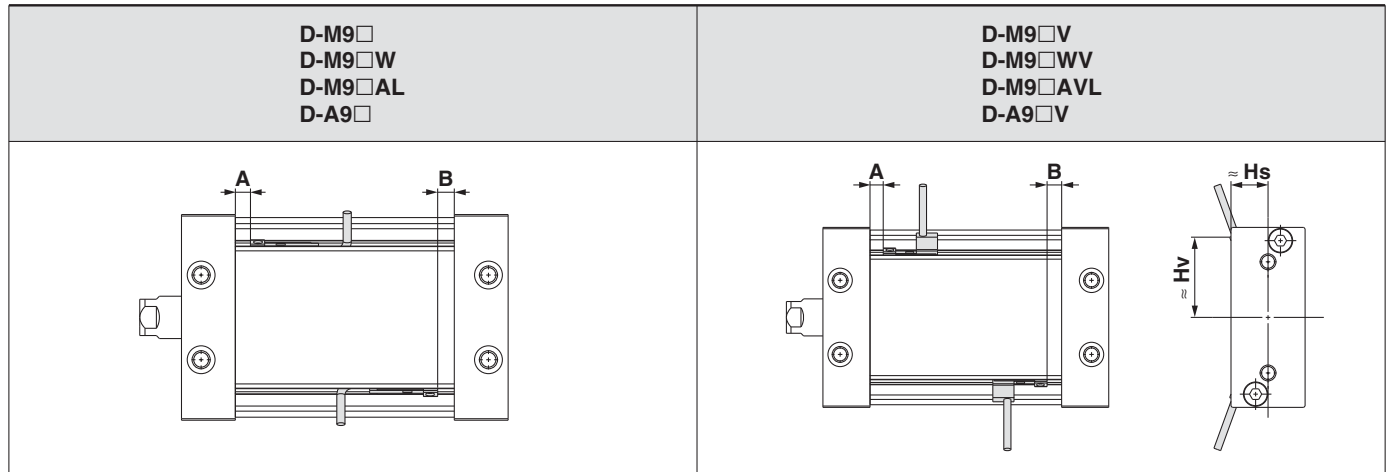

Size	D-M9□ D-M9□W D-M9□AL		D-M9□V D-M9□WV D-M9□AVL				D-A9□		D-M9□V D-M9□WV D-M9□AVL			
	A	B	A	B	Hs	Hv	A	B	A	B	Hs	Hv
25	5	5	5	5	7.5	27.5	1	1	1	1	—	—
32	5	5	5	5	14.5	30	1	1	1	1	—	—
40	5.5	5.5	5.5	5.5	16.5	37	1.5	1.5	1.5	1.5	—	—
50	7	7	7	7	—	—	3	3	3	3	—	—
63	7.5	7.5	7.5	7.5	—	—	3.5	3.5	3.5	3.5	—	—

Minimum Stroke for Auto Switch Mounting

Number of auto switches mounted	D-M9□ D-M9□V D-A9□ D-A9□V	D-M9□W D-M9□WV D-A9□AL D-A9□AVL
1	10	10
2	10	15

Operating Range

Auto switch model	Size				
	25	32	40	50	63
D-M9□/M9□V D-M9□W/M9□WV D-M9□AL/M9□AVL	5.5	5.5	5.5	5	5
D-A9□/A9□V	7.5	8	8	7	6.5

* Since the operating range is provided as a guideline including hysteresis, it cannot be guaranteed. (assuming approx. ±30% dispersion)
It may vary substantially depending on the ambient environment.

Mounting and Moving Method of Auto Switch

A Stroke of 20 or less

1. First insert the auto switch into the switch groove.
2. Then, press the auto switch mounting bracket into the switch groove.

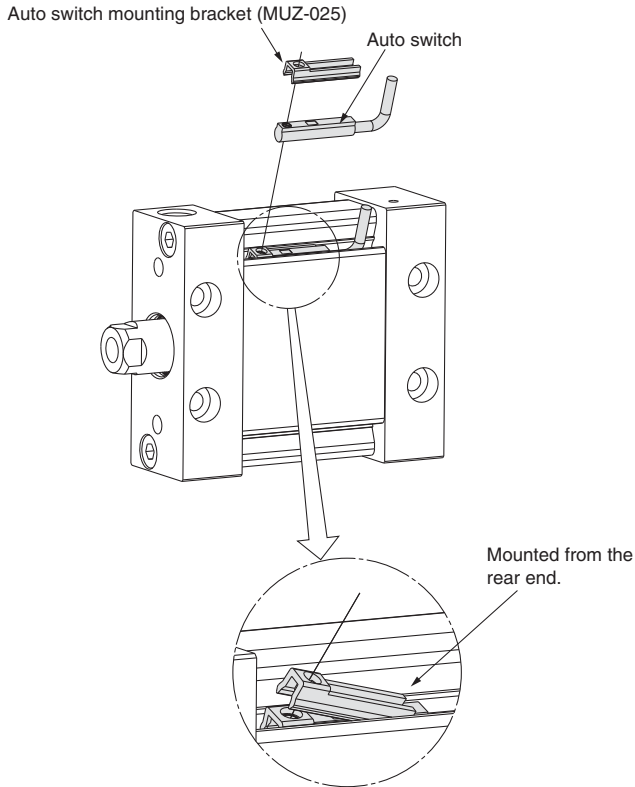

* The auto switch mounting bracket should be mounted from the rear end.

3. Confirm where the mounting position is, and tighten the auto switch mounting screw using a flat head screwdriver to fix the auto switch.

B Stroke of 25 or more

1. First press the auto switch mounting bracket into the switch groove.
2. Then, insert the auto switch into the switch groove, and slide it onto the auto switch mounting bracket.

* Slide the end of the auto switch under the auto switch mounting bracket.

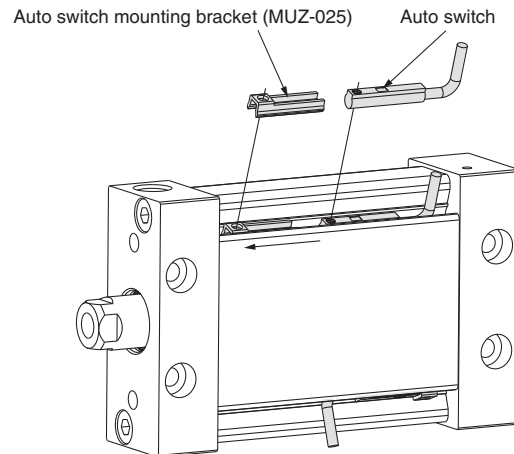

3. Confirm where the mounting position is, and tighten the auto switch mounting screw using a flat head screwdriver to fix the auto switch.

Auto Switch Mounting Bracket Part No.

Cylinder series	Applicable bore size (mm)				
	25	32	40	50	63
MU□-□□Z	MUZ-025				

Note 1) For strokes of 25 or more, mounting method A is also possible.

Note 2) When tightening the auto switch mounting screw, use a watchmaker's screwdriver with the handle diameter of about 5 to 6 mm.

The tightening torque of the mounting screw should be approx. 0.05 to 0.1 N·m.

As a guide, turn an additional 90 degree from the position where it feels tight.

Series MU

Mounting of Magnetic Field Resistant Auto Switch (D-P3DW□ series)

When the magnetic field resistant auto switch (D-P3DW□ series) is mounted, only $\phi 40$ to $\phi 63$ of the existing MU series are available.

How to Order

MDU B 40 □ - 30 D M - P3DWSC □



With auto switch
(Built-in magnet)

Mounting

B	Basic
L	Axial foot
F	Rod flange
G	Head flange
C	Single clevis
D	Double clevis

* Brackets are shipped together, (but not assembled).

Size

40	Equiv. $\phi 40$ piston area
50	Equiv. $\phi 50$ piston area
63	Equiv. $\phi 63$ piston area

Port thread type

Nil	Rc	$\phi 40, \phi 50, \phi 63$
TN	NPT	
TF	G	

Auto switch

Nil	None
-----	------

* For auto switch model, refer to "How to order the auto switch independently."

Number of auto switches

Nil	2 pcs.
S	1 pc.
n	"n" pcs.

* When cylinders/actuators are ordered with an auto switch, the cylinder/actuator, auto switch and auto switch mounting bracket (including screws) are enclosed.
* When the auto switch is ordered on its own, the auto switch mounting bracket is not included. In that case, please order it separately.

Rod end configuration

Nil	Rod end female thread
M	Rod end male thread

Action

D	Double acting
---	---------------

Cylinder stroke (mm)
Refer to "Standard Stroke" on page 2.

How to order the auto switch independently

D-P3DW SC

Lead wire length

SC	0.3 m (M12 connector type: 3 to 4 pins)
SE	0.3 m (M12 connector type: 1 to 4 pins)
Nil	0.5 m
L	3 m
Z	5 m

Auto Switch Proper Mounting Position (Detection at stroke end) and Mounting Height

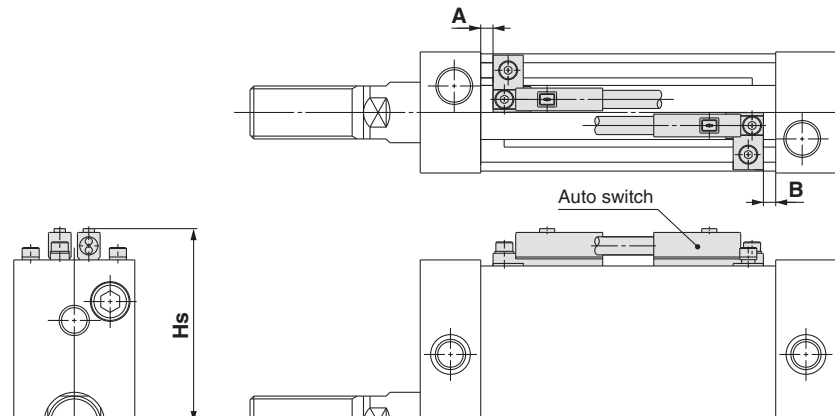

Bore size (mm)	A	B	Hs
40	3	3.5	51.5
50	4.5	5	61
63	5	5.5	71

Minimum Stroke for Auto Switch Mounting

Number of auto switches mounted	Same surface	Different surfaces
1		15
2		15

Auto Switch Operating Range

Bore size (mm)		
40	50	63
6	6	6

* Since the operating range is provided as a guideline including hysteresis, it cannot be guaranteed. (assuming approx. $\pm 30\%$ dispersion)
It may vary substantially depending on the ambient environment.

Mounting and Moving Method of Auto Switch

1. Insert the protrusion on the bottom of the auto switch into the mating part of the auto switch mounting bracket and fix the auto switch and the auto switch mounting bracket temporarily by tightening the hexagon socket head bolt (M2.5 x 9L) 1 to 2 turns.
2. Slide the auto switch mounting nut into the auto switch mounting rail, and place it in the roughly estimated setting position.
3. Fix the auto switch mounting bracket and nut with the hexagon socket head bolts (M3 x 4L) temporarily.
4. Move the auto switch mounting bracket while checking the detection position of the auto switch, and fix it firmly with the hexagon socket head bolts.

Note 1) The torque for tightening the hexagon socket head bolt (M2.5 x 9L) is 0.2 to 0.3 N·m.

Note 2) The torque for tightening the hexagon socket head bolt (M3 x 4L) is 0.5 to 0.7 N·m.

Auto Switch Mounting Bracket Part No. (Including Bracket, Bolt, Nut)

Bore size (mm)		
40	50	63
MDU25-42-4365M-R		

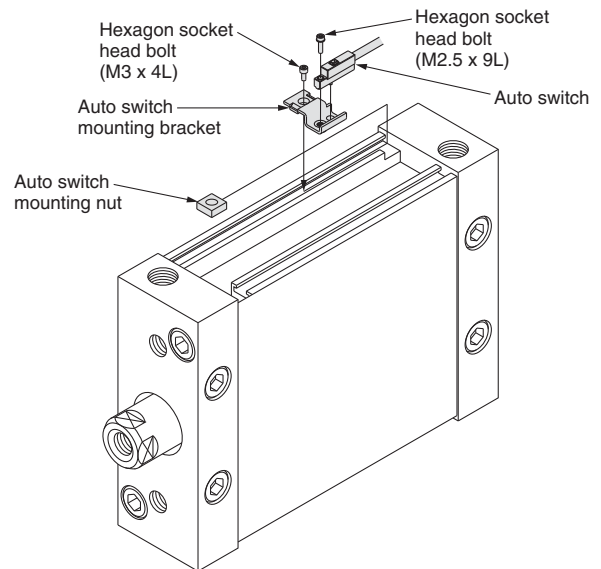





Safety Instructions

These safety instructions are intended to prevent hazardous situations and/or equipment damage. These instructions indicate the level of potential hazard with the labels of “**Caution,**” “**Warning**” or “**Danger.**” They are all important notes for safety and must be followed in addition to International Standards (ISO/IEC)*1), and other safety regulations.

- *1) ISO 4414: Pneumatic fluid power – General rules relating to systems.
- ISO 4413: Hydraulic fluid power – General rules relating to systems.
- IEC 60204-1: Safety of machinery – Electrical equipment of machines. (Part 1: General requirements)
- ISO 10218-1: Manipulating industrial robots - Safety.
- etc.

-  **Caution:** **Caution** indicates a hazard with a low level of risk which, if not avoided, could result in minor or moderate injury.
-  **Warning:** **Warning** indicates a hazard with a medium level of risk which, if not avoided, could result in death or serious injury.
-  **Danger :** **Danger** indicates a hazard with a high level of risk which, if not avoided, will result in death or serious injury.

Warning

1. The compatibility of the product is the responsibility of the person who designs the equipment or decides its specifications.

Since the product specified here is used under various operating conditions, its compatibility with specific equipment must be decided by the person who designs the equipment or decides its specifications based on necessary analysis and test results. The expected performance and safety assurance of the equipment will be the responsibility of the person who has determined its compatibility with the product. This person should also continuously review all specifications of the product referring to its latest catalog information, with a view to giving due consideration to any possibility of equipment failure when configuring the equipment.

2. Only personnel with appropriate training should operate machinery and equipment.

The product specified here may become unsafe if handled incorrectly. The assembly, operation and maintenance of machines or equipment including our products must be performed by an operator who is appropriately trained and experienced.

3. Do not service or attempt to remove product and machinery/equipment until safety is confirmed.

1. The inspection and maintenance of machinery/equipment should only be performed after measures to prevent falling or runaway of the driven objects have been confirmed.
2. When the product is to be removed, confirm that the safety measures as mentioned above are implemented and the power from any appropriate source is cut, and read and understand the specific product precautions of all relevant products carefully.
3. Before machinery/equipment is restarted, take measures to prevent unexpected operation and malfunction.

4. Contact SMC beforehand and take special consideration of safety measures if the product is to be used in any of the following conditions.

1. Conditions and environments outside of the given specifications, or use outdoors or in a place exposed to direct sunlight.
2. Installation on equipment in conjunction with atomic energy, railways, air navigation, space, shipping, vehicles, military, medical treatment, combustion and recreation, or equipment in contact with food and beverages, emergency stop circuits, clutch and brake circuits in press applications, safety equipment or other applications unsuitable for the standard specifications described in the product catalog.
3. An application which could have negative effects on people, property, or animals requiring special safety analysis.
4. Use in an interlock circuit, which requires the provision of double interlock for possible failure by using a mechanical protective function, and periodical checks to confirm proper operation.



Safety Instructions

Caution

1. The product is provided for use in manufacturing industries.

The product herein described is basically provided for peaceful use in manufacturing industries.

If considering using the product in other industries, consult SMC beforehand and exchange specifications or a contract if necessary.

If anything is unclear, contact your nearest sales branch.

Limited warranty and Disclaimer/Compliance Requirements

The product used is subject to the following “Limited warranty and Disclaimer” and “Compliance Requirements”. Read and accept them before using the product.

Limited warranty and Disclaimer

1. The warranty period of the product is 1 year in service or 1.5 years after the product is delivered.*2)

Also, the product may have specified durability, running distance or replacement parts. Please consult your nearest sales branch.

2. For any failure or damage reported within the warranty period which is clearly our responsibility, a replacement product or necessary parts will be provided.

This limited warranty applies only to our product independently, and not to any other damage incurred due to the failure of the product.

3. Prior to using SMC products, please read and understand the warranty terms and disclaimers noted in the specified catalog for the particular products.

***2) Vacuum pads are excluded from this 1 year warranty.**

A vacuum pad is a consumable part, so it is warranted for a year after it is delivered.

Also, even within the warranty period, the wear of a product due to the use of the vacuum pad or failure due to the deterioration of rubber material are not covered by the limited warranty.

Compliance Requirements

1. The use of SMC products with production equipment for the manufacture of weapons of mass destruction (WMD) or any other weapon is strictly prohibited.

2. The exports of SMC products or technology from one country to another are governed by the relevant security laws and regulations of the countries involved in the transaction. Prior to the shipment of a SMC product to another country, assure that all local rules governing that export are known and followed.



Series MU

Specific Product Precautions

Be sure to read before handling.

Refer to back pages 1 and 2 for Safety Instructions, "Handling Precautions for SMC Products" (M-E03-3) for Actuators Precautions.

Mounting

⚠ Caution

1. When a workpiece is secured to the end of the piston rod, ensure that the piston rod is retracted entirely, and place a wrench on the portion of the rod that protrudes beyond the section. Also, tighten in a way that prevents the tightening torque from being applied to the non-rotating guide.

Allowable Torque for Mounting Workpiece (N·m)

Size	25	32	40	50	63
Allowable torque for mounting workpiece	0.25	0.25	0.55	1.25	2.0

2. Operate in such a way that the load to the piston rod is always applied in the axial direction. Furthermore, avoid operations that could apply rotational torque to the piston rod. If rotational torque must be applied due to unavoidable circumstances, make sure the allowable rotational torque is not exceeded.
3. Operating the cylinder by connecting the piping directly to the cylinder can cause the piston speed to exceed the maximum operating speed of 500 mm/s. Therefore, to operate the cylinder, make sure to use an SMC speed controller and adjust the piston speed to 500 mm/s or less.

Handling of Auto Switches

Be sure to read before handling.

Refer to "Handling Precautions for SMC Products" (M-E03-3) for Auto Switches Precautions.

⚠ Warning

1. If multiple cylinders are operated adjacent to each other, the magnets that are enclosed in the adjacent cylinders could affect the operation of the auto switches, causing the switches to malfunction. Therefore, make sure that the mounting pitch of the cylinders is at least that indicated in the below table.

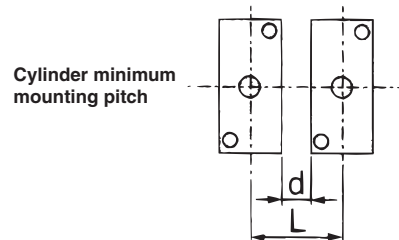

Size	ø25	ø32	ø40	ø50	ø63
L (d)	29 (5)	33 (5)	37 (5)	39 (0)	50 (0)

If cylinders are used with a mounting pitch less than shown above, they must be shielded with iron plates or the separately sold magnetic shielding plate (part no.: MU-S025). Please contact SMC for further information.



Material: Ferrite stainless steel Thickness: 0.3 mm

Since the back side is treated with adhesive, it can be attached to the cylinder.

How to use

In order not to influence the auto switch mounted on cylinder B adjacent to the magnetic force of cylinder A, use a shielding plate to block the magnetic force.

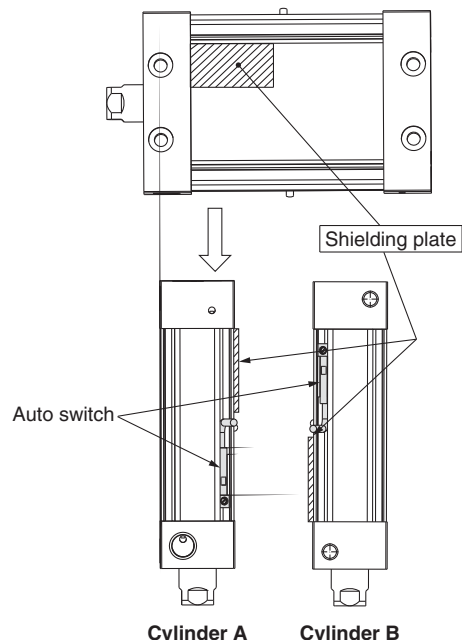

SMC'S GLOBAL MANUFACTURING, DISTRIBUTION AND SERVICE NETWORK

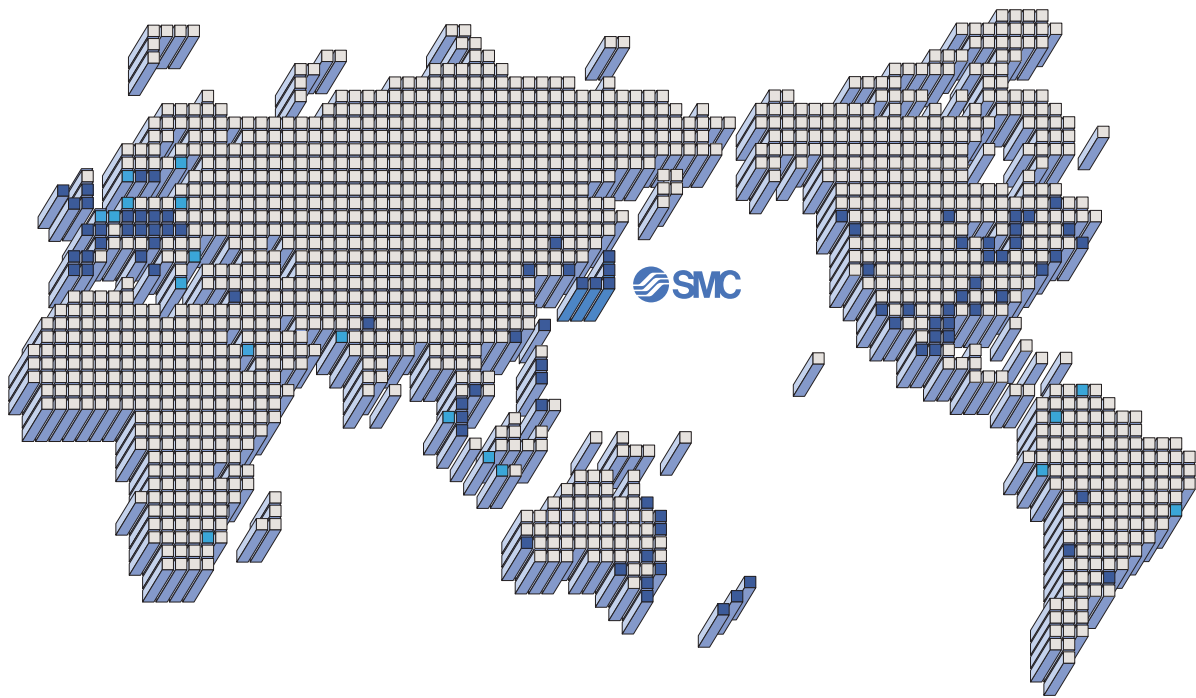

EUROPE

AUSTRIA

SMC Pneumatik GmbH (Austria)

BELGIUM

SMC Pneumatics N.V./S.A.

BULGARIA

SMC Industrial Automation Bulgaria Eood

CROATIA

SMC Industrijska Automatika d.o.o.

CZECH REPUBLIC

SMC Industrial Automation CZ s.r.o.

DENMARK

SMC Pneumatik A/S

ESTONIA

SMC Pneumatics Estonia OÜ

FINLAND

SMC Pneumatics Finland Oy

FRANCE

SMC Pneumatique SA

GERMANY

SMC Pneumatik GmbH

GREECE

SMC Hellas E.P.E.

HUNGARY

SMC Hungary Ipari Automatizálási Kft.

IRELAND

SMC Pneumatics (Ireland) Ltd.

ITALY

SMC Italia S.p.A.

LATVIA

SMC Pnuematics Latvia SIA

LITHUANIA

UAB "SMC Pneumatics"

NETHERLANDS

SMC Pneumatics B.V.

NORWAY

SMC Pneumatics Norway AS

POLAND

SMC Industrial Automation Polska Sp.z.o.o.

ROMANIA

SMC Romania S.r.l.

RUSSIA

SMC Pneumatik LLC

SLOVAKIA

SMC Priemyselna Automatizacia Spol s.r.o.

SLOVENIA

SMC Industrijska Avtomatika d.o.o.

SPAIN/PORTUGAL

SMC España S.A.

SWEDEN

SMC Pneumatics Sweden AB

SWITZERLAND

SMC Pneumatik AG

U.K.

SMC Pneumatics (U.K.) Ltd.

ASIA

CHINA

SMC (China) Co., Ltd.

HONG KONG

SMC Pneumatics (Hong Kong) Ltd.

INDIA

SMC Pneumatics (India) Pvt. Ltd.

MALAYSIA

SMC Pneumatics (S.E.A.) Sdn. Bhd.

PHILIPPINES

Shoketsu SMC Corporation

SINGAPORE

SMC Pneumatics (S.E.A.) Pte. Ltd.

SOUTH KOREA

SMC Pneumatics Korea Co., Ltd.

TAIWAN

SMC Pneumatics (Taiwan) Co., Ltd.

THAILAND

SMC (Thailand) Ltd.

NORTH AMERICA

CANADA

SMC Pneumatics (Canada) Ltd.

MEXICO

SMC Corporation (Mexico), S.A. de C.V.

U.S.A.

SMC Corporation of America

SOUTH AMERICA

ARGENTINA

SMC Argentina S.A.

BOLIVIA

SMC Pneumatics Bolivia S.r.l.

BRAZIL

SMC Pneumáticos do Brasil Ltda

CHILE

SMC Pneumatics (Chile) S.A.

VENEZUELA

SMC Neumatica Venezuela S.A.

OCEANIA

AUSTRALIA

SMC Pneumatics (Australia) Pty. Ltd.

NEW ZEALAND

SMC Pneumatics (N.Z.) Ltd.



Safety Instructions

Be sure to read "Handling Precautions for SMC Products" (M-E03-3) before using.

SMC Corporation

Akihabara UDX 15F,

4-14-1, Sotokanda, Chiyoda-ku, Tokyo 101-0021, JAPAN

Phone: 03-5207-8249 Fax: 03-5298-5362

URL <http://www.smcworld.com>

© 2009 SMC Corporation All Rights Reserved

Specifications are subject to change without prior notice and any obligation on the part of the manufacturer.

D-DN

1st printing NT printing NT 6000SZ Printed in Japan.

This catalog is printed on recycled paper with concern for the global environment.